

48783

Radio - BUILD A DIGITAL LOCK FOR YOUR TELEPHONE

GET THE FAX!

NOVEMBER 1988

Electronics®

TECHNOLOGY - VIDEO - STEREO - COMPUTERS - SERVICE

THE FACTS ON FAX

Find out why everyone is making a fuss about this year's hottest technology

COPING WITH COILS

How to design and build your own inductors

BUILD R-E's POWER MONITOR

To keep tabs on the quality of your AC power

COMPUTERDIGEST

EIA-232—A serial interface that we can all agree on?



\$2.25

IN CANADA \$2.75

- PLUS:**
- ★ Don Lancaster's Hardware Hacker
 - ★ Larry Klein's Audio Update
 - ★ What's New ★ Video News
 - ★ Communications Corner





PHILIPS

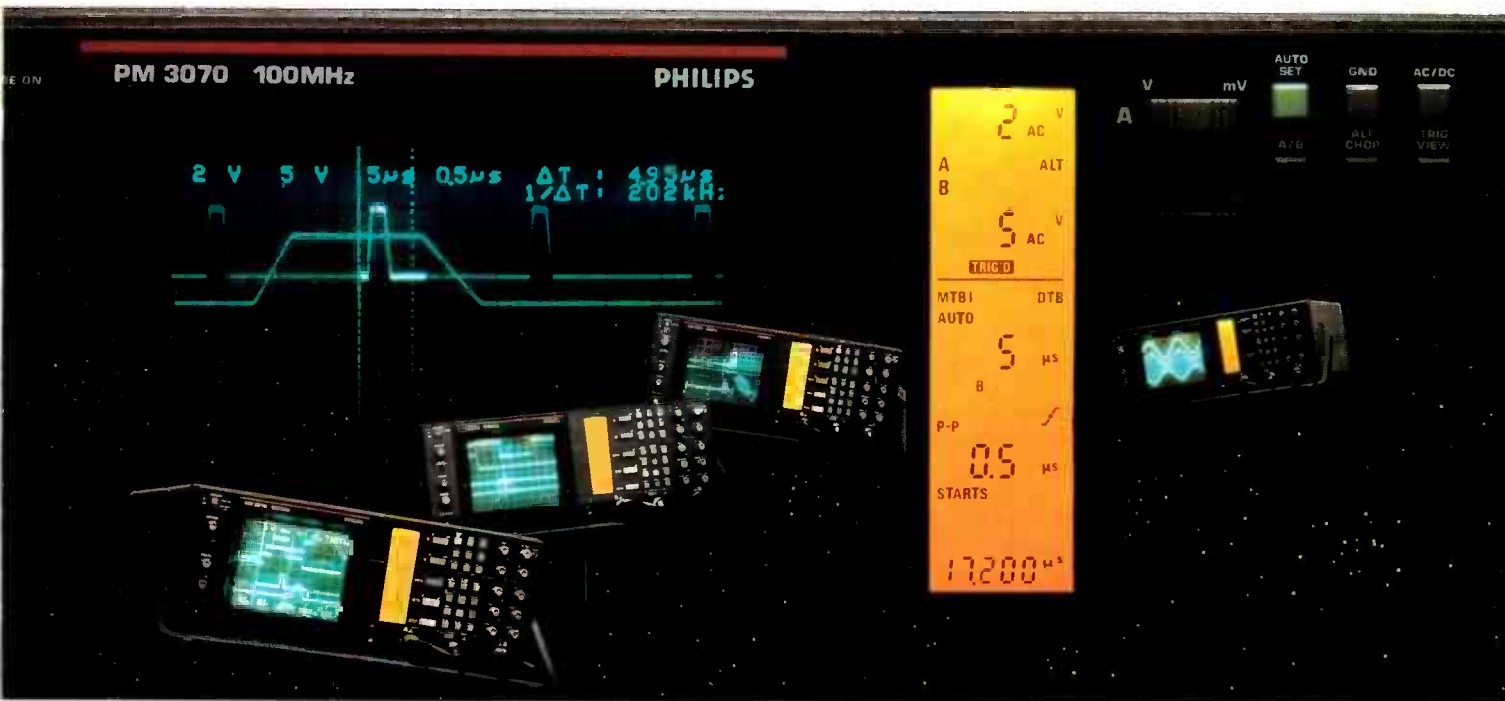

Introducing a whole new way to look at oscilloscopes.

Operation that's instinctively, unbelievably clear. Information that's detailed, yet free of errors. And intelligence that will speed your work. Philips' micro-computer controlled medium-frequency Smart Series. They could change forever the way you look at oscilloscopes.

HIGH PERFORMANCE WITH A VIEW

- **LCD window.** Large digital indications note all selected functions, instrument settings and parameter values. Instantly. Precisely. With no mistakes. And right where you need them—next to the CRT. Not hidden in crowded frontpanels. Not wasting critical waveform display area. It's a revolutionary idea that facilitates the use of an oscilloscope like nothing else. And it's only from Philips. Once again.
- **16kV CRT.** Higher acceleration voltage and advanced electron optics assure brilliance and spot quality that outshines anything else in this class.
- **Pushbutton simplicity.** Quick, one-function buttons have replaced knobs for faster, surer, more reliable operation.

- **Instant-action AUTOSET.** Philips' intelligent beamfinder automatically selects channel, amplitude, timebase and triggering for error-free display of any input signal. Great for troubleshooting!
- **"Clever" cursors and delayed sweep.** Standard on the PM 3070, "clever" cursors supply immediate amplitude and timing measurements with direct CRT readout. And an exclusive cursor-operated ZOOM function offers the most efficient use of delayed sweep available in analog scopes.
- **Auto-Triggering intelligence.** Provides fast, stable triggering up to 150 MHz.
- **Probefactor compensation in LCD.** It automatically adjusts all readouts for the probe you're using.
- **IEEE compatibility.** For fast computer hook-up and automated production test and calibration.
- **Choice of four models:** Single and dual timebase; 60 or 100 MHz bandwidths.

SUPPORTING VIEW

Philips' medium-frequency instruments come with a 3-year warranty, a 30-day money-back guarantee and all the tech-

nical and service assistance you need. From Fluke—the people who believe that extraordinary technology deserves extraordinary support.

POINT OF VIEW

Call Fluke today at **800-44-FLUKE ext. 77**. And find out how easy it is to change the way you look at oscilloscopes.

Ask for your free copy of our new guidebook, Basic Principles of Oscilloscopes.

John Fluke Mfg. Co., Inc., P.O. Box C9090, M/S 250C, Everett, WA 98206
U.S.: 206-356-5400 CANADA: 416-890-7600
OTHER COUNTRIES: 206-356-5500

© Copyright 1988 John Fluke Mfg. Co., Inc.
All rights reserved. Ad No. 0481-P3065/70



SMART SERIES OSCILLOSCOPES • 60 & 100 MHz



CIRCLE 121 ON FREE INFORMATION CARD

BUILD THIS

- 55 POWERLINE MONITOR**
Keep an eye on AC-power conditions.
Gary McClellan
- 59 DIGITAL TELEPHONE LOCK**
Part 2. Construction details.
Steve Sokolowski
- 65 Radio Electronics Advanced Control System.**
Automate your home with the REACTS X-10 module.
Michael A. Tucker

TECHNOLOGY

- 45 THE FACTS ON FAX**
How facsimile machines work, and why they're becoming so popular.
Herb Friedman
- 50 FACSIMILE: 1940 — 1988**
A firsthand look at the development of fax technology.
Carl A. Helber

CIRCUITS

- 67 COPING WITH COILS**
Use our program to design and build your own inductors.
David E. Powell, KA4KNG

DEPARTMENTS

- 6 VIDEO NEWS**
What's new in this fast-changing field.
David Lachenbruch
- 22 EQUIPMENT REPORTS**
Command Communications TF500 auto telephone switches.
- 32 HARDWARE HACKER**
A cheap color fuser.
Don Lancaster
- 42 AUDIO UPDATE**
The Audio Engineering Society.
Larry Klein
- 74 DRAWING BOARD**
Multiplexing and dynamic RAM.
Robert Grossblatt
- 78 COMMUNICATIONS CORNER**
Double your modem's data throughput.
Herb Friedman

COMPUTER DIGEST
A NEW KIND OF MAGAZINE FOR ELECTRONICS PROFESSIONALS
#100-238
A real technical magazine for electronics professionals. Page 87
THE SYNERGY CARD
Finish it up and put it to work. Page 90
ADVANCED FLOPPY DISK CONTROLLERS
Add more power to your PC. Page 84

PAGE 83



For all the extra bits you can get by using a controller, you'll need a controller.

...the only way to get more bits is to use a controller. The controller is the device that takes care of the data transfer between the floppy disk and the computer. It's a small circuit board that fits into a slot on the computer's motherboard. The controller is responsible for managing the data flow between the disk and the computer. It's a complex task, but it's essential for the computer to be able to read and write data from the floppy disk. The controller is also responsible for managing the timing of the data transfer. It makes sure that the data is transferred at the right time and in the right order. Without a controller, the computer would be unable to use a floppy disk. So, if you want to use a floppy disk, you'll need a controller. The controller is a small circuit board that fits into a slot on the computer's motherboard. It's a complex task, but it's essential for the computer to be able to read and write data from the floppy disk. The controller is also responsible for managing the timing of the data transfer. It makes sure that the data is transferred at the right time and in the right order. Without a controller, the computer would be unable to use a floppy disk. So, if you want to use a floppy disk, you'll need a controller.

PAGE 45

AND MORE

- 120 Advertising and Sales Offices**
- 120 Advertising Index**
- 12 Ask R-E**
- 121 Free Information Card**
- 14 Letters**
- 100 Market Center**
- 24 New Products**
- 71 PC Service**
- 4 What's News**

ON THE COVER



Facsimile machines have been around for almost half a century. However, it took the advent of digital electronics—and the resultant quality improvement and price reduction—to bring fax into the mainstream. Now, consumer-electronics experts are predicting that home fax machines will soon become as common as PC's and videocameras. To discover what's behind the technology and fax machines' rise in popularity, turn to page 45. To learn how they've developed over the years, from someone who was there from the beginning, see page 50.

COMING NEXT MONTH

THE DECEMBER ISSUE IS ON SALE NOVEMBER 1

INTERACTIVE TV

Play TV game shows in real time, competing against other viewers, with this exciting new technology.

RADIO DATA SYSTEM

Get more than just aural information from your FM radio.

BUILD A VIDEO EDIT CONTROLLER

Make clean edits between scenes on your videotapes.

GATED-SYNC DESCRAMBLING

Restore horizontal-sync pulses to gated-sync scrambled signals.

COMPUTER DIGEST

BUILD A SPEECH SYNTHESIZER

Use National's Digitalker system with your computer.

As a service to readers, RADIO-ELECTRONICS publishes available plans or information relating to newsworthy products, techniques and scientific and technological developments. Because of possible variances in the quality and condition of materials and workmanship used by readers, RADIO-ELECTRONICS disclaims any responsibility for the safe and proper functioning of reader-built projects based upon or from plans or information published in this magazine.

Since some of the equipment and circuitry described in RADIO-ELECTRONICS may relate to or be covered by U.S. patents, RADIO-ELECTRONICS disclaims any liability for the infringement of such patents by the making, using, or selling of any such equipment or circuitry, and suggests that anyone interested in such projects consult a patent attorney.

RADIO-ELECTRONICS (ISSN 0033-7862) November 1988. Published monthly by Gernsback Publications, Inc., 500-B Bix County Boulevard, Farmingdale, NY 11735 Second Class Postage paid at Farmingdale, NY and additional mailing offices. Second-Class mail registration No. 9242 authorized at Toronto, Canada. One-year subscription rate U.S.A. and possessions \$17.97, Canada \$23.97, all other countries \$26.97. All subscription orders payable in U.S.A. funds only, via international postal money order or check drawn on a U.S.A. bank. Single copies \$2.25. © 1988 by Gernsback Publications, Inc. All rights reserved. Printed in U.S.A.

POSTMASTER: Please send address changes to RADIO-ELECTRONICS, Subscription Dept., Box 55115, Boulder, CO 80321-5115.

A stamped self-addressed envelope must accompany all submitted manuscripts and/or artwork or photographs if their return is desired should they be rejected. We disclaim any responsibility for the loss or damage of manuscripts and/or artwork or photographs while in our possession or otherwise.

Radio Electronics®

Hugo Gernsback (1884-1967) founder
M. Harvey Gernsback,
editor-in-chief, emeritus

Larry Steckler, EHF, CET,
editor-in-chief and publisher

EDITORIAL DEPARTMENT

Art Kleiman, editorial director

Brian C. Fenton, editor

Carl Laron, WB2SLR,
editorial associate

Marc Spiwak, associate editor

Jonathan A. Gordon,
assistant technical editor

Teri Scaduto, assistant editor

Jeffrey K. Holtzman,
computer editor

Robert A. Young, assistant editor

Byron G. Wels, editorial associate

Jack Darr, CET, service editor

Robert F. Scott,
semiconductor editor

Herb Friedman,
communications editor

Robert Grossblatt, circuits editor

Larry Klein, audio editor

David Lachenbruch,
contributing editor

Don Lancaster,
contributing editor

Richard D. Fitch,
contributing editor

Kathy Campbell, editorial assistant

Andre Duzant, technical illustrator

Injae Lee, assistant illustrator

PRODUCTION DEPARTMENT

Ruby M. Yee, production director

Robert A. W. Lowndes,
editorial production

Karen Tucker, advertising production

Marcella Amoroso, production traffic

CIRCULATION DEPARTMENT

Jacqueline P. Cheeseboro,
circulation director

Wendy Alanko,
circulation analyst

Theresa Lombardo,
circulation assistant

Nancy Estrada, manager,
R-E Bookstore

Typography by Mates Graphics
Cover photo by Herb Friedman

Radio-Electronics is indexed in
Applied Science & Technology Index
and *Readers Guide to Periodical Literature*.

Microfilm & Microfiche editions are
available. Contact circulation department
for details.

Advertising Sales Offices listed
on page 120.



NEW**POCKET SIZE****SIZE: 4" H x 3.5" W x 1" D
MADE IN USA**

FREQUENCY COUNTERS TO 2.4 GHz

**8 LED DIGITS • 2 GATE TIMES
ALUMINUM CABINET
INTERNAL NI-CAD BATTERIES INCLUDED
AC ADAPTER/CHARGER INCLUDED**

#TA-100S

**EXCELLENT SENSITIVITY
& ACCURACY****AC-DC • PORTABLE
OPERATION**

Small enough to fit into a shirt pocket, our new 1.3 GHz and 2.4 GHz, 8 digit frequency counters are not toys! They can actually out perform units many times their size and price! Included are rechargeable Ni-Cad batteries installed inside the unit for hours of portable, cordless operation. The batteries are easily recharged using the AC adapter/charger supplied with the unit.

The excellent sensitivity of the 1300H/A makes it ideal for use with the telescoping RF pick-up antenna; accurately and easily measure transmit frequencies from handheld, fixed, or mobile radios such as: Police, firefighters, Ham, taxi, car telephone, aircraft, marine, etc. May be used for counter surveillance, locating hidden "bug" transmitters. Use with grid dip oscillator when designing and tuning antennas. May be used with a probe for measuring clock frequencies in computers, various digital circuitry or oscillators. Can be built into transmitters, signal generators and other devices to accurately monitor frequency.

The size, price and performance of these new instruments make them indispensable for technicians, engineers, schools, Hams, CBers, electronic hobbyists, short wave listeners, law enforcement personnel and many others.

STOCK NO:

#1300H/A	Model 1300H/A 1-1300 MHz counter with preamp, sensitivity, < 1mV, 27MHz to 450MHz includes Ni-Cad batteries and AC adapter	\$169.95
#2400H	Model 2400H 10-2400 MHz microwave counter includes Ni-Cad batteries and AC adapter	\$299.95
#CCA	Model CCA counter/counter, for debugging, ultra sensitive, < 50 micro volts at 150MHz I-600 MHz with adjustable threshold, RF indicator LED. Includes Ni-Cad batteries and AC adapter	\$299.95

ACCESSORIES:

#TA-100S	Telescoping RF pick-up antenna with BNC connector	\$12.00
#P-100	Probe, direct connection 50 ohm, BNC connector	\$20.00
#CC-12	Carrying case, gray vinyl with zipper opening. Will hold a counter and #TA-100S antenna.	\$10.00



FLA (305) 771-2050

ORDER FACTORY DIRECT

1-800-327-5912**AVAILABLE NOW!**
OPTOELECTRONICS INC.
**5821 N.E. 14th Avenue
Ft. Lauderdale, Florida 33334**

Orders to US and Canada add 5% of total (\$2 min, \$10 max)
Florida residents add 6% sales tax. COD fee \$2.
Foreign orders add 15%

CIRCLE 191 ON FREE INFORMATION CARD

WHAT'S NEWS



GE ENGINEER DR. RICHARD I. HARTLEY adjusts the flexible tips of a new welding system that carries the power on thin fiber-optic cables and applies the heat to both sides of the weld simultaneously.

New laser-welding system uses fiber-optic cables

A new laser-welding system, that fires its intense energy through needle-thin fiber-optic cables and heats both sides of the

workpiece simultaneously, is in use at a General Electric plant in North Carolina. Each of the 75-foot-long fiber-optic cables in the new welding system carries a laser beam of up to 100 watts of power.

The cables are extremely flexible, so their tips—the “windows” that the beams come through—are easily positioned on opposite sides of a workpiece.

In 1983, General Electric scientists demonstrated that a fiber-optic cable can carry several hundred watts of average power without suffering damage. The problem was how to inject a laser beam into one end of a hair-thin electrical fiber without damaging its protective coating or melting the glass. That problem was tackled by Dr. Marshall G. Jones of the GE Research and Development Center. He and his associates developed an “input coupler”—an optical assembly that reduces the $\frac{3}{4}$ -inch laser beam to the diameter of the glass fiber in the fiber-optic cable. Its transmission efficiency is 90 percent.

The new technology is being used in a GE lighting plant in Goldsboro, NC to weld lead wires to the filaments of electric bulbs used in auto headlamps. Two conductors, one of nickel-plated iron wire and one of molybdenum, must be welded together end-to-end. The iron wire is about twice the diameter of the molybdenum. Applying the heat from both sides makes a more symmetrical and stronger joint than that produced by earlier approaches.

Satellite-TV pirates hit with \$130K damages

U.S. District Court Judge Thomas E. Scott (Miami, FL) awarded General Instrument Corp., HBO, and Showtime, \$130,000 in statutory damages—and granted a permanent injunction from marketing, using, importing, selling, distributing, abetting, or manufacturing any device designed to unlawfully intercept satellite pay-television programming services—against Shaun Kenny, Bob Cooper, and Network

Productions, Inc. of New Jersey.

Judge Scott awarded \$110,000 in statutory damages against Shaun Kenny, \$20,000 against Bob Cooper and Network Productions, and plaintiff attorneys' fees that will be determined at a later hearing in Miami.

The suit was filed by Cable/Home Communications Corp. (a subsidiary of General Instrument Corp.), Home Box Office, Inc., Showtime/The Movie Channel, and M/A-Com, Inc. It alleged that Network Productions, Kenny, and

Cooper had violated U.S.-copyright laws and infringed upon copyrights of the VideoCipher descrambling technology that is used to deliver subscription programming to the home satellite-TV market.

It further alleged that Cooper, Kenny, and Network Productions had violated the Federal Communications Act, that prohibits the design, manufacture, marketing, and use of devices intended to receive encrypted signals without authorization. **R-E**

DAMARK MUST LIQUIDATE

AT FAR BELOW DEALER COST!

INTERNATIONAL, INC.

PUBLIC NOTICE:
 Due to a variety of reasons, (overproductions, discontinued lines, Etc...) manufacturers & distributors get STUCK with inventories that must be liquidated. DAMARK walks in, lays down cash, and takes the entire inventory. This is how we can offer you products at BELOW DEALER COST! Just LOOK at the values below and order today - QUANTITIES ARE LIMITED!

Sherwood

Now enjoy live performance sound with this Sherwood Optimum Digital Receiver with "Surround Sound" and the Sherwood Auto Reverse Double Cassette Deck. By adding additional speakers to the back of your room you can create "surround sound"!



- RECEIVER SPECS:**
- 3-way speaker switching.
 - Quartz-locked computerized tuning.
 - 16 station presets. • Auto scan tuning.
 - 35 watts per channel.

- DUAL CASSETTE SPECS:**
- Dubbing cassette deck.
 - 3 auto reverse playback modes.
 - Dolby B & C. • Remote capability.
 - Bidirectional automatic music search.
 - 2 dubbing speeds.
 - Full logic tape control.
- Both have Full Factory Warranty.
 • All are Factory New! Factory Perfect!

RECEIVER
 Manufacturer's Suggested Retail \$219.95

DAMARK PRICE:
\$129

Order No. B-882-107672
 Insured Ship/Hand. \$9.50

CASSETTE DECK
 Manufacturer's Suggested Retail \$329.95

DAMARK PRICE:
\$198

Order No. B-882-107680
 Insured Ship/Hand. \$11.00

SUZUKI ELECTRONIC GUITAR



UNISYNTH XG-1

IT'S THE INSTRUMENT OF TODAY! Digital synthesizer voices, stringless membrane fingerboard, digital drums and electronic tremolo put the UNISYNTH in an entirely new category of guitar technology! Features an exciting "Auto-Play" function for anyone that wants to play guitar but doesn't know how! In just minutes you'll be playing the guitar of today!

- 6 different synthesizer voices: Guitar I, II, Synth, Vibes I, II & Brass.
- 8 rhythm patterns including rock, disco, latin, 8 beat, ballad, waltz, 16 beat, and swing.
- Touch responsive right hand strum strings.

Manufacturer's Suggested Retail \$349.95

DAMARK PRICE:
\$99

Order No. B-882-105973
 Insured Ship/Hand. \$9.00

GTE CORDLESS PHONE



Always have access to those important calls by taking the GTE Cordless Phone along! Take it from room to room in your home or office building. It even goes outside and you still get a clear, crisp conversation.

- Handset operates up to approx. 1000 ft. from base unit.
- Paging from base to handset.
- Preset security code
- One-touch redial of last number.
- Tone/pulse dialing.
- Model #: 3100. • Color: Beige.
- Factory serviced, but like new!
- 90 Day Limited Warranty!

Manufacturer's Suggested Retail \$99.95

DAMARK PRICE:
\$59

Order No. B-882-107771
 Insured Ship/Hand. \$6.00

AMBICO MTS STEREO DECODER



Add stereo excitement to your TV viewing with this state-of-the-art Ambico MTS Stereo Decoder. Creates TRUE stereo for most TV's! All cables included.

- Works with any tuner for TV (CATV cable converter, VCR, remote TV tuner, TV with MPX output).
- Automatically decodes stereo signals broadcast through antenna or cable.
- Slim, compact size. 9.75"Wx7"Dx1.5"H.
- All necessary cables included.
- **FULL 90-DAY WARRANTY!**

Manufacturer's Suggested Retail \$129.00

DAMARK PRICE:
\$49

Order No. B-882-102624
 Insured Ship/Hand. \$6.00

CODE-A-PHONE PERSONAL ANSWERING SYSTEM

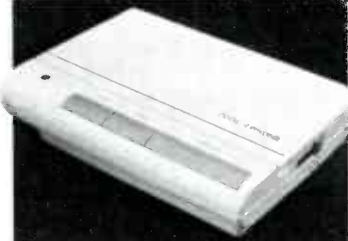

Keep in touch with those important messages while away from your phone! Sleek & compact, this functional answering machine will prove to you over & over again how valuable it really is!

- "Beeperless" remote control.
- Personal access code.
- Remote turn-on.
- Personal memo record.
- Voice-activated recording.
- One-touch message playback.
- Full Factory Warranty!
- Factory Serviced, but like new!

Manufacturer's Suggested Retail: \$109.95

DAMARK PRICE:
\$59

Order No. B-882-106815
 Insured Ship/Hand. \$5.00

FOR FASTEST SERVICE CALL TOLL FREE 1-800-950-9090



PRODUCT	ITEM NO.	QTY.	PRICE	S/H/I	TOTAL
SHERWOOD Receiver	B-882-107672		\$129	\$9.50	
SHERWOOD Double Deck	B-882-107680		\$198	\$11.00	
SUZUKI Electronic Guitar	B-882-105973		\$99	\$9.00	
GTE Cordless Telephone	B-882-107771		\$59	\$6.00	
AMBICO Stereo Decoder	B-882-102624		\$49	\$6.00	
CODE-A-PHONE	B-882-106815		\$59	\$5.00	
			SUB TOTAL		
			in MN add 6% Sales Tax		
			Total S/H/I		
			TOTAL		

CORPORATE OFFICE (612) 560-5415
 DELIVERY TO 48 U.S. CONTINENTAL STATES ONLY

Sub Total
 in MN add 6% Sales Tax
 Total S/H/I
 TOTAL

NAME _____
 ADDRESS _____
 CITY _____ ST _____ ZIP _____
 PHONE _____

Check/Money Order VISA
 MasterCard Discover CARD NO. _____ EXP. DATE _____

Send To: DAMARK INTERNATIONAL, INC., 6707 Shingle Creek Parkway, Minneapolis, MN 55430

VIDEO NEWS



DAVID LACHENBRUCH,
CONTRIBUTING EDITOR

● **Downsizing 8mm.** If you think you've seen some miniature VCR's and camcorders, you ain't seen nothing yet. Sony—which only recently introduced the 8mm Video Walkman, combining an LCD-color TV with an 8mm VCR (**Radio-Electronics**, September 1988)—has now developed an 8mm tape-transport mechanism occupying only one-third the space of original versions. The head drum is only about 1.05 inches in diameter—so small that it largely fits inside the cassette when recording or playing.

One of the secrets of Sony's miniaturization is cutting the drum size from 40 mm to 26.7 mm. That increases the tape wrap around the drum to 292 degrees from 190 degrees and doubles the number of video heads to four. With that move, Sony obviously hopes to win the miniaturization race with the VHS-C format. (The VHS group has already miniaturized the drum, increased the tape wrap, and doubled the number of heads). The VHS-C drum may now be down to its irreducible minimum.

In addition to reducing the head-drum size, all other components in the 8mm deck have been cut in size and weight. The new mechanical assembly is claimed to have one-half the weight (6.5 ounces), one-third the volume, and one-half the thickness of original 8mm mechanisms. Sony is offering the new transport to other manufacturers. It should show up in recorders some time in 1989.

● **Cable and HDTV.** Like the broadcasters, cable-TV systems are looking at the prospects for high-definition TV and will conduct their own tests soon. Two major cable entities—American Telecommunications Co. and Home Box Office, both subsidiaries of Time, Inc.—have outlined their view of attributes to be considered for a cable HDTV system:

- At least 850 lines of horizontal and vertical resolution in both static and moving images;
- Occupancy of one 6-MHz RF channel;
- Need for "little or no rebuild" of the typical cable system;

- Ability to coexist with standard channels on a cable system;
- Adaptability to future evolutionary picture improvements;
- Ability to accommodate real-time, live HDTV programming;
- Easy interface with HDTV program-production systems;
- Four CD-quality audio channels;
- Built-in scrambling system;
- Ability to be delivered to cable systems by satellite;
- Recordable on VCR's and optical discs.

Those two cable entities envision "multi-standard" TV receivers designed for a "family of HDTV transmissions," from broadcast, cable and VCR sources.

● **More 35-in Tubes.** There's only one place in the world where 35-inch color-picture tubes are being manufactured for the global market—and that's the Kyoto, Japan, plant of Mitsubishi Electric. That largest mass-produced tube (known as 37-inch in countries that use over-all diagonal instead of picture-diagonal measurement) is made with special glass, in a heavily automated plant. The result is a tube weighing 132 pounds, as compared with 330 pounds, if it were made using materials and methods used in smaller tubes. Mitsubishi will turn out about 130,000 of those giants this year—some 100,000 going into Mitsubishi sets and the rest sold to other TV-set manufacturers, including JVC, Sharp and Zenith. Although the American picture-tube industry is expanding to produce tubes with diagonal measurements up to 32 inches, none of the U.S. manufacturers plan to make tubes as big as Mitsubishi's giant. The demand for 35-inch tubes is greater than the supply, and Mitsubishi is expected to increase production in 1989.

Is anything bigger on the way? Sony has demonstrated a prototype 43-inch Trinitron but has given no availability information. Mitsubishi experimented with a 43-inch tube, but shelved

the project when it was determined that a set that big will not fit through the doors of most homes.

● **Videodisc "Singles."** A new lower-cost type of videodisc has been approved by the Laserdisc group in Japan and is being explored in the United States and Europe. The 8-inch, one-sided "single" disc is made of polycarbonate material instead of the traditional acrylic and provides 20 minutes playing time. Today's two-sided 8- and 12-inch discs must be pressed in special plants—where capacity is limited—and consist of two discs glued together. The new singles can be pressed in many compact-disc plants—that currently have excess capacity—and are inherently cheaper to produce. The new discs are compatible with all existing laserdisc players and are similar in many respects to the 5-inch CD-Video discs that provide up to six minutes of video and 20 minutes of digital audio. It's not known when the new 8-inch video singles will be available.

● **Tubeless Projection TV.** Projection television could lose its cathode-ray tubes and gain a light bulb. Sharp has demonstrated a TV projector that uses three 3-inch liquid-crystal displays as light valves—one for each primary color—and whose picture size is variable from 20

to 100 inches in diagonal measurement. A newly developed 100-watt lamp providing 6,600 lumens of white light is the light source, with a claimed life of more than 2,000 hours. The picture is still rather coarse—92,160 pixels—but the contrast ratio is 100:1. The projector looks more like an old magic lantern than a TV set. Sharp says it will be on the market in Japan next spring. Other companies are also working on three-LCD projection systems and one American company, Comtrex International, is marketing a single-LCD projector at \$2,295.

● **Bigger LCD TV's.** Flat-screen TV sets are getting bigger. Although few LCD color-TV's today are bigger than about 3 inches in diagonal measurement, they'll be growing soon. Hitachi is selling a 5-inch model in Japan, and Casio plans to introduce one with a 6-inch screen there this year. A 6.3-incher with 300,000-pixel resolution is in the works from Hitachi, and both Hitachi and Casio say they're working on 7-inch models. Hitachi's uses non-interlace scanning for higher resolution. They're both said to be due next year. Next will come a 10-incher, also from Hitachi. The biggest surprise, however, was Sharp's demonstration of a 14-inch LCD color-TV with a picture claimed to be comparable to that of a CRT set—and scheduled for introduction as early as next spring.

R-E

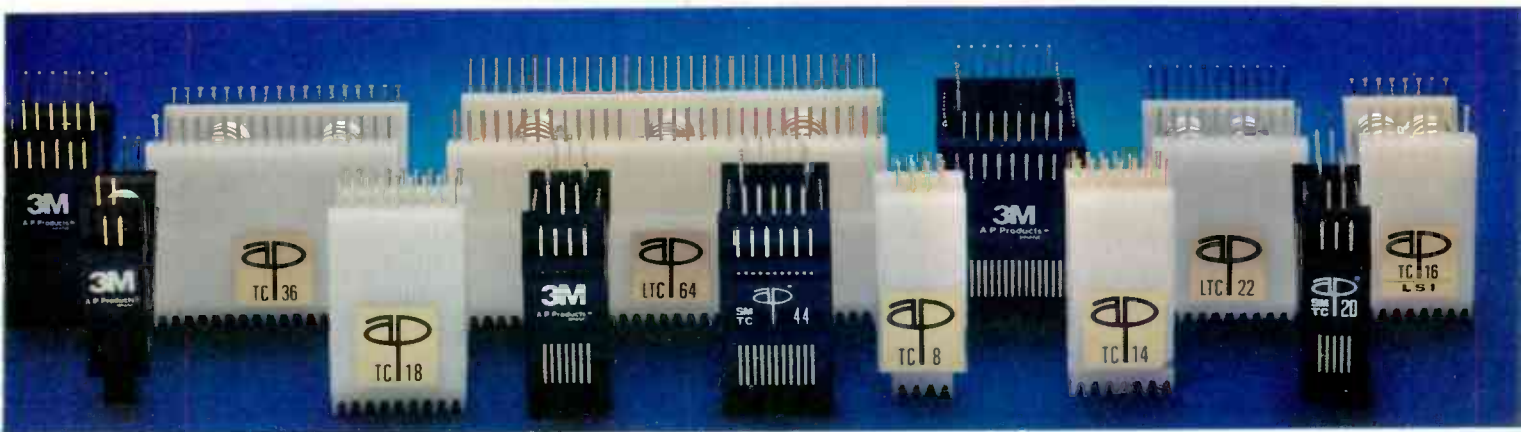

Test Clips For Every Purpose.

Your Electronic Specialty Products distributor has a wide selection of 3M Test Clips in quantities from one to 1,000.

Test DIP ICs, SOICs, PLCC ICs and LCC ICs. 3M Test Clips make hard-to-reach leads accessible. Used for lab and field service, prototyping, production testing and QA/QC inspection, 3M Test Clips are a must for any complete electronics tool kit or bench.

Every 3M Test Clip is designed for easy, positive attachment on today's high density boards. And we build them with the type of reliability you've come to expect from 3M.

For the name of your nearest 3M Test Clip distributor, call toll free 800-321-9668 or (216) 354-2101 in Ohio.

Electronic Specialty Products
3M Electronic Products Division
9325 Progress Parkway
Mentor, Ohio 44060

We've Packaged Our Solutions.

CIRCLE 76 ON FREE INFORMATION CARD



NOVEMBER 1988

7

An affordable portable is

Price/Bandwidth

\$4995 100 MHz 2230 DSO*, 20 MS/s, 4K Record Length, 100 ns Glitch Capture, Cursors, CRT Readout, GPIB or RS-232-C Option

\$3995 60 MHz 2221 DSO, 20 MS/s, 4K Record Length, 100 ns Glitch Capture, Cursors, CRT Readout, GPIB or RS-232-C Option

\$2995 60 MHz 2220 DSO, 20 MS/s, 4K Record Length, 100 ns Glitch Capture, GPIB or RS-232-C Option

\$2995 100 MHz 2236 Two Channel, Counter/Timer/DMM, Dual Time Base

\$2395 100 MHz 2246A Four Channel, Store/Recall of 20 Front Panel Setups, Auto Setup, Smart Cursors,™ Dual Time Base

\$2395 50 MHz 2210 DSO, 20 MS/s Sample Rate, 4K Record Length

\$1795 100 MHz 2245A Four Channel, Auto Setup, Cursors, Dual Time Base

\$1595 100 MHz 2235 Two Channel, Dual Time Base

\$1095 50 MHz 2225 Two Channel, Horizontal Magnification (x5, x10, x50)

\$695 20 MHz 2205 Two Channel

Digital Storage Oscilloscope

Check the prices and performance. You'll find the best measure of both in Tek 2200 Series Oscilloscopes. Ten scopes with bandwidths ranging from 20 to 100 MHz. Two and four channels. Analog and digital. And prices starting at just \$695.

Select for such features as automatic setup, time and voltage cursors, built-in DMM functions and dual analog/digital capabilities at the push of a button.

These are scopes you'll appreciate for their well-proven reliability, achieved through simplified, practical internal design. They come complete with probes and comprehensive Tek warranty that includes the CRT.

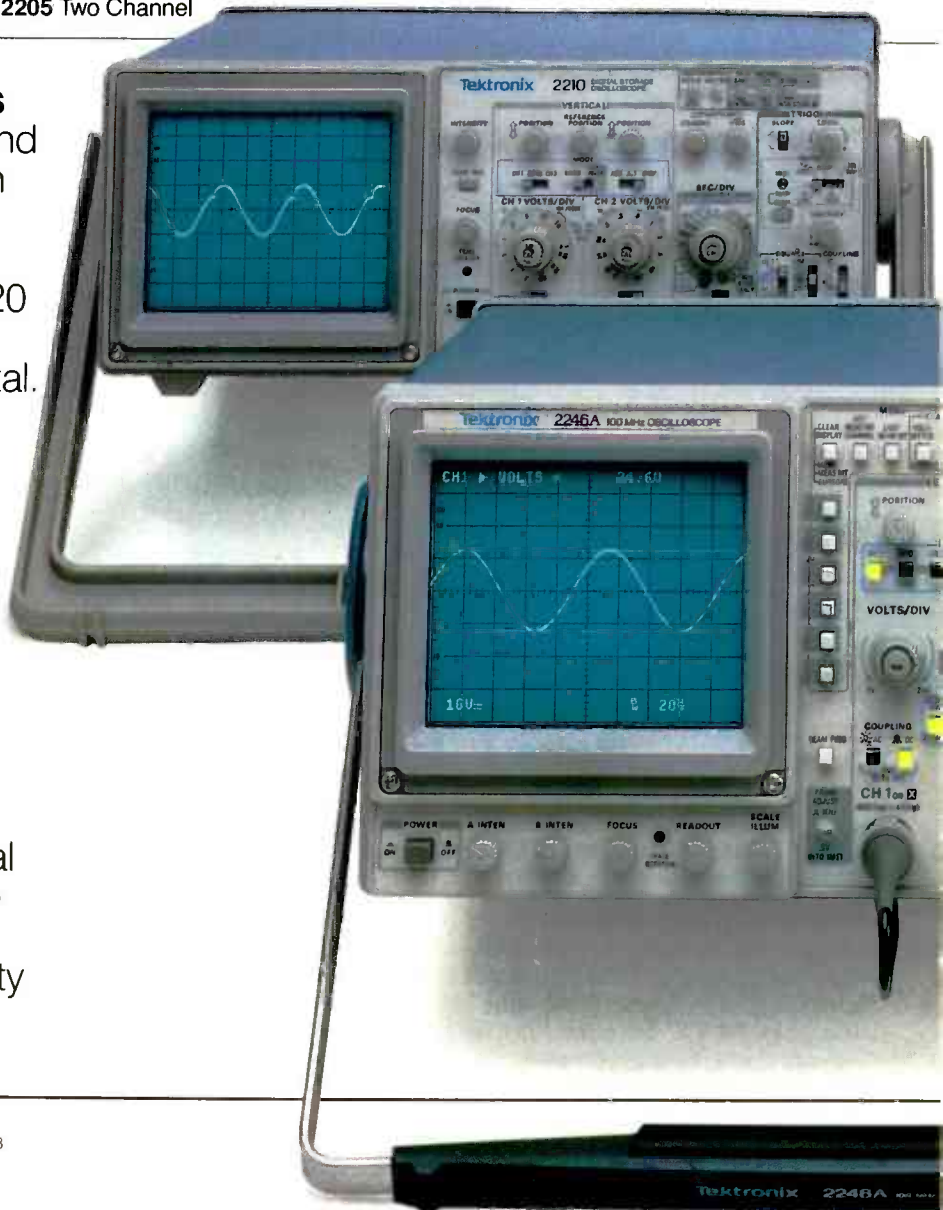

right within your range.

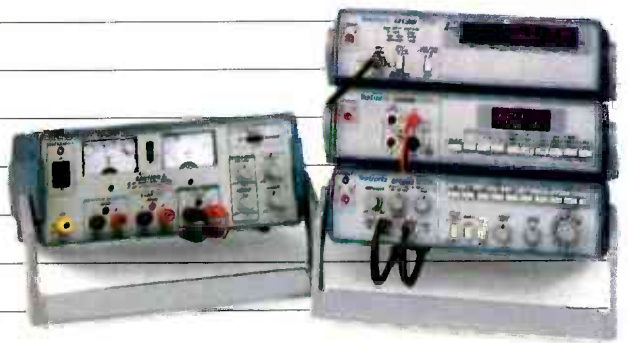

Industrial-quality test instrumentation starting at \$295.



Ask those who own, use and rely on one—on the bench or in the field. There's just no substitute for genuine Tek quality. At any price. And at these prices, all the better.

Order one to go. Ask your Tek representative to set up a demo. Or call Tek direct. No need to settle for less when there's a top quality Tek portable with performance and price right within your range.

For easy ordering or more information, call Tek direct:

1-800-426-2200



Tektronix
COMMITTED TO EXCELLENCE

CIRCLE 92 ON FREE INFORMATION CARD

www.americanradiohistory.com

ASK R-E

WRITE TO:

ASK R-E
Radio-Electronics
500-B Bi-County Blvd.
Farmingdale, NY 11735

Z-80 UPGRADE

I have an old Z80-A based Morrow MicroDecision MD3 and I would like to modify it to run at 8 MHz with a Z80-H. I'm planning on replacing all the original memory with faster chips (120 ns) but in studying the data sheets, I keep coming across two timing specifications—access time and cycle time. I know what access time is, but I don't know what cycle time refers to.—C. M., Austin, TX

When you decide to use DRAM in a circuit design you're really opening a can of worms. While it's true that they save board space, power, and money, there's no getting around the fact that using them can be a one way ticket to the rubber room.

Speeding up a computer requires more than just changing the CPU, clock, and DRAM. Those are the obvious things but there are some subtle ones as well, and trying to find the problems they cause can produce an unbelievable amount of brain damage.

Using 120-ns DRAM with an 8-MHz clock means that you won't be getting any grief due to access time. It also means that the cycle time is only of academic interest but, since you asked, here's the deal.

The timing chart in Fig. 1 is an abbreviated version of all the various DRAM parameters. One look at the address lines will show you that a lot of stuff has to happen before you can get to the data. The row address and column address have to be sequentially presented to the address pins and strobed into the internal latches by RAS and CAS. Once the DRAM has the address stored, it needs some time to

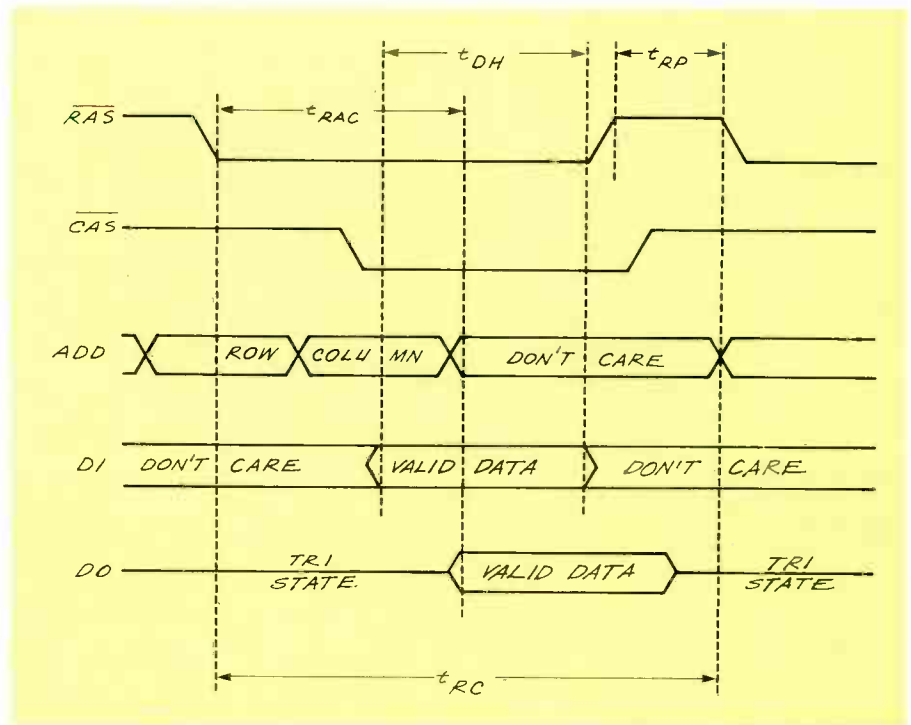

FIG. 1

access the particular cell and make it available for either a read or a write.

The time it takes to get from RAS (row address strobe) to the point where data shows up is the "access time," usually referred to as t_{RAC} in the data books. The data stays valid for a predefined amount of time known as t_{DH} (the data hold time). Toward the end of that period, the internal latches have to reset themselves to be able to accept the next RAS pulse. That is known as the RAS precharge time (t_{RP}), and the DRAM won't accept another address until after t_{RP} has passed.

If you're repeatedly accessing memory and you want to do it as fast as possible, the chip's access time gives you only part of the sto-

ry. The access time tells you how quickly the data will show up when you address the chip but you can't get data from a different address until t_{RP} has passed. The minimum amount of time that has to pass between RAS pulses is the cycle time (t_{RC}).

Most data sheets will give you t_{RC} , but a good rule of thumb is that:

$$t_{RC} = t_{RAC} + t_{DH} + t_{RP}$$

The cycle time is actually a little less than that since there are overlaps, but it's close and gives you a worst-case figure. If you want to learn more about DRAM, check out the "Drawing Board" series on these devices that started back in May 1987.

What has to be done to speed up a computer varies from machine to machine. Unfortunately it's the subtleties that are different. The things to watch are ROM speeds, I/O, and video on the hardware side and time-sensitive BIOS routines in the firmware. And get yourself a commented BIOS listing since journeying through the BIOS without one is just about impossible.

SPARK-GAP CAP?

When salvaging components from discarded TV sets, I often run across funny looking components that are noted as "spark-gap capacitors" on the parts list or schematic. I can't find any mention of those parts in any TV theory and servicing manuals. What are they?—D.H. Vancouver, BC.

Spark gaps may be needed at any number of points in a TV circuit. They protect low-voltage and delicate components against damage from high-voltage surges and transients. They are simply two small pointed or rounded electrodes fixed in position in a ceramic packaging, and they frequently resemble a disc capacitor to the untrained eye.

A voltage surge or a transient voltage that attempts to rise above a safe value, arcs across the spark gap's electrodes, which guide the voltage surge or transient around the circuit or the components being protected.

You may find spark gaps between picture-tube cathodes and ground; to discharge high-voltage picture-tube transients and to pre-

Networks R1/C1 and R2/C2 are Capristors; safety devices consisting of a spark gap, high-voltage capacitor, and high-value resistor, all in parallel. The Capristors prevent shock hazards at the antenna terminals of TV's that don't have isolating-type power transformers. The capacitors have a reactance of around 18 megohms at line frequencies and are, in effect, open circuits. At TV frequencies, the capacitors appear as short circuits with reactances of less than 20 ohms across the VHF band.

Resistors R1 and R2 protect the capacitors against being punctured by high electrostatic charges that may build up on the antenna during thunder storms. The resistors permit the charges to leak off to ground before they can reach damaging levels. The spark gaps protect the capacitors against fast-rise high-voltage charges that may not be discharged fast enough through the resistors. The Capristors may resemble a disc capacitor with two small "horns" protruding from the top. R-E

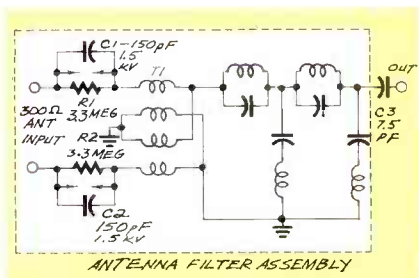

FIG. 2

vent damage to other components. You may find them in color amplifiers, horizontal-deflection circuits, and very often in the TV-antenna matching and filter network, as shown in Fig. 2.

Up to 50% Savings on Probes



Model SP100
Switchable 1X-10X \$ **43.**

Performance
Guaranteed

TEST PROBES, INC. **TPI**

9178 Brown Deer Road
San Diego, CA 92121

Call toll free for information and free catalog:
1-800-368-5719
1-800-643-8382 in CA

ORDER FROM THESE DISTRIBUTORS

Or Phone Toll Free for the Distributor Nearest You



1-800-535-9593
1-800-462-9520 LA

contact east Metermaster

1-800-225-5370
(508) 682-2000 MA

1-800-962-8128
(213) 685-4340 CA

Specialized
PRODUCTS COMPANY

1-800-527-5018
(214) 550-1923 TX

Active

1-800-363-6592 Canada
1-800-363-7601 QUE

ALCOTRON

(617) 879-7650



JENSEN TOOLS INC.

(602) 968-6231

BCS ELECTRONICS
LIMITED

(416) 661-5585

ALLIED ELECTRONICS INC.
A SUBSIDIARY OF HALL MARK ELECTRONICS CORP.

1-800-433-5700, (817) 336-5401 TX

WESTCON INC.

(503) 283-0132 OR, (206) 223-1133 WA

CIRCLE 123 ON FREE INFORMATION CARD

LETTERS



STILL MORE ON THE MACRO-SCRUBBER

I built the Macro-Scrubber that appeared in the December 1987 issue of *Radio-Electronics*. It is a good circuit, but it has some flaws that I corrected.

In the July 1988 issue, a letter from Robert Maslak called out the fact that the 14 microsecond window of the original circuit failed to filter out a lot of the *Macrovision* pulses. I implemented his circuit fix and found that it took care of most of the problem. However, I wanted to find a further fix that would take care of the *Macrovision* pulses at the very beginning of the vertical-blanking interval. That can be done with the addition of a few more parts. Rather than change the crystal, as Mr. Maslak suggests, I changed IC4's count by cutting and jumpering to a count of 9. See Fig. 1.

The philosophy of operation is based on triggering IC13 one shot by a pulse that is at the beginning of the vertical blanking. Because there is no pulse generated at the beginning of the vertical interval, a way to create one is needed. If the vertical-sync serration pulse (IC6 pin 12)—which occurs 190 microseconds into the vertical interval—is used to synchronize a free-running pulse-delay generator, a circuit approach is defined.

If the vertical-sync serration pulse is inverted and applied to the reset line of a 4060 (IC12, a binary counter and oscillator) that is set to the correct frequency, then the trigger pulse from IC12 for IC13 will be at the right time. Because IC12 stops counting during the vertical-sync serration-reset pulse, the correct delay from IC12 pin 1 must be 16.2856 milliseconds. That

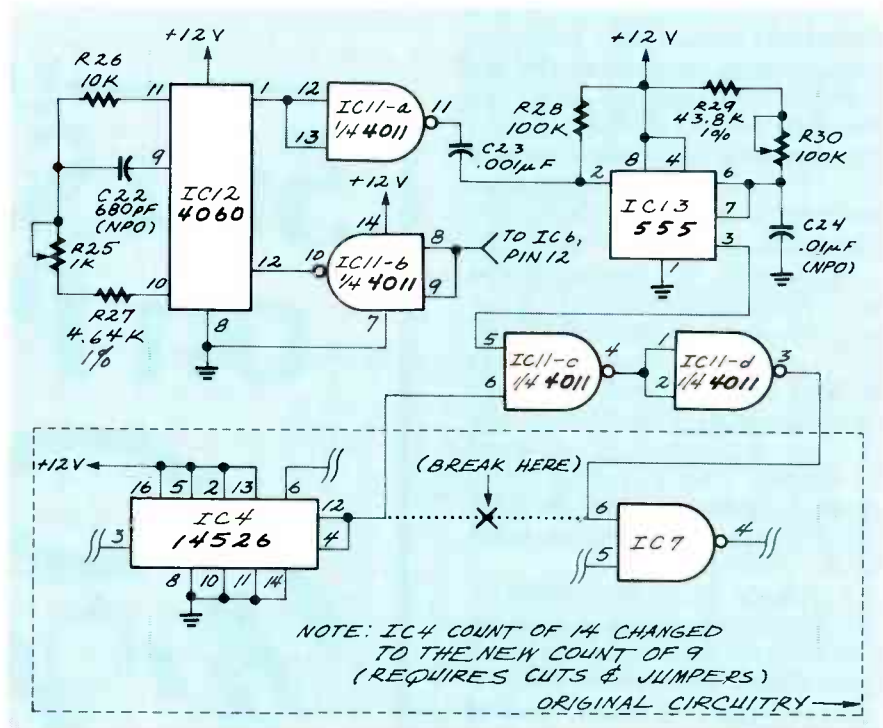

FIG. 1

translates to an oscillator frequency of 125.75 kHz. That oscillator frequency is determined by R25, R27, and C22. The 4060 gives a precise, repeatable long delay, that would be difficult to get using a one-shot approach. The fixed resistors should be 1% and the capacitors should be NPO ceramic for temperature stability.

Circuit adjustment is best accomplished using an oscilloscope. If the pulse from IC13 pin 3 is used to sync the video-out signal (applied to the input of the scope), R25 is adjusted so that the trace just begins at the vertical-blanking interval. Next, change the scope input to IC13 pin 3, and change R30 until the pulse length is one vertical interval long, that would be 1.33 milliseconds.

That circuit modification is all that is necessary to remove all of the *Macrovision* pulses. Observation with a scope shows a complete video "cleanup"—but the actual viewing on TV passes the "acid test."

JACK SLAGER
N. Hollywood, CA

THE DEBATE CONCLUDES

In a letter to *Radio-Electronics* (September 1988), Richard A. Bowen claimed that "If Mr. Mims had his way, possessing an ordinary pencil would be against federal law as it could be used as a weapon to kill." Gosh, I hope not. All those hand-lettered books I do for Radio Shack are written with—you guessed it—a pencil.

I can live with Mr. Bowen's "pen-

cil-cide" charge since it's so silly. But in the remainder of his letter, Mr. Bowen totally misrepresented some statements I expressed in the November 1987 and May 1988 issues of **Radio-Electronics**.

At issue was the October 1987 cover story, "Build This Laser Listener." Its lead paragraph warned that "Breaking and entering to plant a listening device...can earn someone a long jail term." The article then suggested that "A better and safer way to bug a room is to use a laser beam to eavesdrop on a window from across the street." Furthermore, a heading presented the device as a means "...to listen in to anything, anywhere, any time."

What **Radio-Electronics** did not tell its readers is that bugging a room with a laser can also earn someone a long jail term and heavy fines. Nor did **Radio-Electronics** warn its readers that it is a violation of federal law and many state laws to even build or possess an electronic device whose sole purpose is eavesdropping.

That is the key point of my previous correspondence. I don't have any problem with articles about laser eavesdropping; I've written several myself. I have also demonstrated laser eavesdropping on several local and national television programs. However, I part company with **Radio-Electronics** and Mr. Bowen when they endorse the violation of federal and state laws.

How would Mr. Bowen react if a curious neighbor aimed the Laser Listener at his bedroom? How would **Radio-Electronics** feel if I, a columnist for *Modern Electronics*, aimed it at **Radio-Electronics'** editorial offices?

I know exactly what I'll do if someone aims a Laser Listener at my office! First I'll place a corner reflector in the beam to overload the detector. Then I'll get my infrared viewer, sneak up on the eavesdropper, and zap him with a **Radio-Electronics** stun gun. Finally, I'll tie up the culprit with my wire-wrap tool, stack him on a fire-ant mound, and call the law. If he comes back again, I'll dust off the light-seeking rocket I built back in 1967 and see if it still works.
FORREST M. MIMS, III

Radio-Electronics does not endorse the violation of any federal or state laws. Our rather sensational opening to the Laser Listener story was meant to be taken tongue-in-cheek—anyone who tries to bug a room with a visible laser deserves what he gets! In hindsight, we should have been more responsible. Fortunately, our Laser Listener's sole purpose was not eavesdropping. Its purpose was to give our readers a way to experiment with communications by using modulated light beams.—Editor

SURROUND SOUND KUDOS

I read, with interest, the letters from Mr. Dressler and Mr. Wood (**Radio-Electronics**, June 1988), concerning the theory and applications of surround sound. I am a retired electronics technician, and I have the finest audio and video components. I've had access to several high-priced commercial surround-sound decoders. I also read your article concerning surround sound (April 1988), and built the decoder you presented.

ATTENTION!
ELECTRONICS
TECHNICIANS



**EARN YOUR
B.S.E.E.
DEGREE
THROUGH HOME STUDY**

Our New and Highly Effective Advanced-Placement Program for experienced Electronic Technicians grants credit for previous Schooling and Professional Experience, and can greatly reduce the time required to complete Program and reach graduation. No residence schooling required for qualified Electronic Technicians. Through this Special Program you can pull all of the loose ends of your electronics background together and earn your B.S.E.E. Degree. Upgrade your status and pay to the Engineering Level. Advance Rapidly! Many finish in 12 months or less. Students and graduates in all 50 States and throughout the World. Established Over 40 Years! Write for free Descriptive Literature.

**COOK'S INSTITUTE
OF ELECTRONICS ENGINEERING**

 4251 CYPRESS DRIVE
JACKSON, MISSISSIPPI 39212

CIRCLE 58 ON FREE INFORMATION CARD

SAVE BUY DIRECT

15-DAY FREE TRIAL

MAX 1.3G Frequency Counter

- 50 Hz to 1,300 MHz response
- 8-digit LED display
- Handheld
- Antenna



\$199

Our new MAX 1.3G frequency counter is as small as a calculator, but big in performance. This hand-held, battery-powered counter goes wherever you need accurate, reliable, simple operation. And we're offering the MAX 1.3G at our incredibly low catalog price of only \$199. Our new catalog also offers a large selection of electronics testing and prototyping equipment at low direct-from-the-factory prices... proving you really can buy the *best for less!*

Call TOLL-FREE
1-800-345-6251
(1-800-445-6250 in Connecticut)

To order your MAX 1.3G at our low catalog price simply call our toll-free order line, mention this ad and have your Visa or MasterCard ready. Or send your check with the coupon below.

There's a lot in our new catalog that will interest you. Send the coupon below and we'll put you on our mailing list.

**FREE
Catalog**



- Enclosed is my check for the MAX 1.3G.
(CT and CA residents include state sales tax.)
- Please send me your new Global Direct Catalog.

Name _____

Company _____

Address _____

City _____

State _____

Zip _____



Global Specialties
Mail Order Division
P.O. Box 1405
New Haven, CT 06505

CIRCLE 197 ON FREE INFORMATION CARD

After making many comparisons, I find **Radio-Electronics'** decoder excellent. My family and friends have truly enjoyed the results. I completely agree with the author that noise reduction and time delay are not necessary for home use. I also like having the ability to remove the 7-kHz cut off for certain applications.

WALTER RASKOFSKY
Bloomfield, NJ

L/C METER ENHANCEMENT

Thanks to the thoughtfulness and expertise of one of your readers, Ken Walters, an important improvement in the reliability of my "L/C Meter" (**Radio-Electronics**, July 1988) was brought to my attention. I'd like to pass that information along to other readers.

At large values of capacitance (greater than 25,000 pF) erratic operation may result due to a "spike" in the output waveform of the LM311 oscillator. Mr. Walters was smarter than I in that he read the LM311 application notes. (As they say, "if all else fails, read the

instructions.")

If you experience erratic operation at large values of capacitance, or are unable to successfully calibrate the unit because the frequency appears to be twice what I specified on the calibration capacitor, the cure is to solder pins 5 and 6 of the LM311 (8-pin DIP) together. Pins 5 and 6—intended for connection to an offset-balance potentiometer—act as parasitic inputs if they are not used.

The soldering can be done on either the top or bottom of the board, as you see fit. The problem seems to occur most on units that have a socket for the LM311. All assembled units I ship in the future will have that modification. Those units already shipped operate up to 68,000 pF, as that is what I used to calibrate them.

NEIL W. HECKT
5211 117th S.E.
Bellevue, WA 98006

...ON A CLEAR DAY

An even simpler way of finding true north than that shown in "Ask

R-E" would be to use a magnetic compass and find out the compass deviation from true north from your county surveyor, a nautical map, or at the public library. The deviation can be either plus or minus—so you have to be sure to get that right.

You can also find true north using a simplified method of the process shown in Figure 1 in September's "Ask R-E" column. Drive a thin stick in the ground so that it stands 2 or 3 feet straight up and down. Put a small stone to mark the point where the tip of the shadow falls. Wait until the shadow moves a couple of feet and place another stone at the tip of shadow.

Next, sight along the line between the two markers, and draw a straight line to the point where the line passes closest to the stick. A line from the base of the stick to that point would indicate true north.

You do need a sunny day.
ROY A. NORMAN
Brunswick, GA

R-E

BK PRECISION



Test
Instrument
SALE!



FREE CATALOG

MODEL 540
Component Tester
Reg. \$995.00 SALE \$836.95

MODEL 541
Component Comparator
Reg. \$395.00 SALE \$332.95

MODEL 560
Programmable In/Out-
of Circuit IC Tester
Reg. \$3500.00 SALE \$2940.95

MODEL 2120
Oscilloscope, 20MHz
Dual Trace
Reg. \$520.00 SALE Call for
Quote

MODEL 2125
Oscilloscope, 20MHz Dual-
Trace, with Delayed Sweep
Reg. \$620.00 SALE \$478.95



MODEL 388-HD
Test Bench
Reg. \$139.00
SALE \$106.95



Products International Inc.
8931 Brookville Rd.
Silver Spring, MD 20910 U.S.A.
(800) 638-2020 (301) 587-7824

Complete B & K Line Available,
"Call for your Price Quotations"

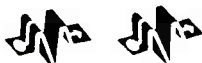

NOISE REDUCTION FOR UNDER \$10.

MIXING CONSOLES
SWITCHES
MICROPHONE
CONNECTORS
SNAKE CABLES
BATTERY CONTACTS



ALL PLUGS & JACKS
(XLR, PHONE, PHONO, DIN, MIDI, ETC.)
PATCHBAYS
FADERS, POTS
TERMINAL STRIPS
SPEAKER TERMINALS

CRAMOLIN®

Even the finest equipment in the world cannot guarantee noise-free operation. One "dirty" connection anywhere in the electrical path can cause unwanted noise or signal loss.

"MORE THAN A CONTACT CLEANER"

CRAMOLIN® is a fast-acting, anti-oxidizing lubricant that cleans and preserves all metal surfaces, including gold.

When applied to metal contacts and connectors, **CRAMOLIN®** removes resistive oxides as it forms a protective molecular layer that adheres to the metal surfaces and maintains maximum electrical conductivity.

CRAMOLIN® - USED BY THOSE WHO DEMAND THE BEST:

Bell & Howell	Hewlett Packard	MCI(Sony)	Nakamichi
Boeing	John Fluke Mfg.	Motorola	RCA
Capitol Records	McIntosh Labs	NASA	Switchcraft

SINCE 1956

CAIG LABORATORIES INC.

1175-O Industrial Ave., (P.O. Box J) - Escondido, CA 92025-0051 U.S.A. • (619) 743-7143

CIRCLE 50 ON FREE INFORMATION CARD

NEW! Measure to the MAX with the first Test Bench™ you can hold in your hand

For \$139.00 you can replace a bench full of instruments



Micro-miniaturization strikes again! B&K-PRECISION has combined the capabilities of five popular instruments into one hand-held Test Bench™ unit. This 41 range voltmeter, ammeter, ohmmeter, frequency counter, capacitance meter, logic probe, transistor and diode tester features an extra-large LCD display, ruggedized case and B&K-PRECISION quality.

You don't need a trunk full of instruments to get the job done. See your local B&K-PRECISION distributor for immediate delivery on the new 388-HD Test Bench™.

Large 3½ Digit LCD Readout. High-contrast display, slanted for easy viewing

Diode Test. Quick check of diode junctions

DC and AC Volts. 0.5% DCV accuracy

Integral Tilt Stand. Can be detached and used to hang DMM on vertical surface

Single Rotary Switch. Convenient range and function selection

Resistance. 0.1Ω to 2000 MΩ

hFE Measurement. Measures transistor gain

Audible Continuity Beep indicates a complete circuit

Logic Level Measurement. Checks TTL levels

Frequency Measurement. 20Hz-200kHz

DC and AC Current

Capacitance Measurement. Up to 20μF

20 Amp Range

ZAP Proofed. High-Energy Fused



BK PRECISION
MAXTEC INTERNATIONAL CORP.

6470 W. Cortland St. • Chicago, IL 60635 • 312-889-1448
International Sales, 6470 W. Cortland St., Chicago, IL 60635

Canadian Sales, Atlas Electronics, Ontario
South and Central American Sales, Empire Exporters, Plainville, NY 11803

CIRCLE 77 ON FREE INFORMATION CARD

Four-foot Drop Resistant
Heavy Duty Case, Bright yellow safety color

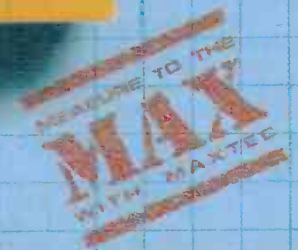

REASONS FOR SELECTING CIE

- Approved for educational benefits under the G.I. Bill for Veterans and other eligible persons.
- CIE provides printed job resumes, letters of recommendation, and lifetime Employment Service for all graduates at no extra charge.
- State-of-the-Art laboratory equipment is yours to keep and it comes assembled, ready for hands-on-experiments.
- Only CIE offers an Associate Degree program based on actual study time used. The faster you complete your degree, the less your overall tuition.
- Upon graduation, CIE offers you free preparation to pass the Certified Electronics Technician Exam.



CIE

CLEVELAND INSTITUTE OF ELECTRONICS 1776 East 17th Street • Cleveland Ohio 44114
PHONE TOLL FREE 1-800-321-2155 / In Ohio 1-800-523-9109

LEARNING...

THE KEY TO SUCCESS

A CAREER IN ELECTRONICS STARTS WITH CIE.

For the last few years, the electronics field and related industries have been growing at an incredible pace. And today, a career in electronics offers more opportunities and greater rewards than ever before.

Just ask any of the many graduates of the Cleveland Institute of Electronics who have landed high-paying positions with aerospace, computer, medical and communications firms. They'll tell you success didn't come easy... but that CIE made it all worthwhile.

SPECIALIZED TRAINING CIE isn't just another be-everything-to-everybody correspondence school. We're accredited by the National Home Study Council. And with more than 1100 graduates each year, we're the largest independent home study school specializing *exclusively* in electronics. CIE has been training career-minded students like yourself for over 50 years and we know the business inside and out.

PRACTICAL TRAINING CIE students learn by doing, using sophisticated electronic learning tools that we've designed and developed. One such tool, our 4K RAM Microprocessor Training Laboratory, teaches programming, interfacing and lets you work with a broad range of computers in a way that working with a single, stock computer simply can't.

We combine that valuable hands-on training with our unique Auto Programmed[®] lessons, designed to teach you step-by-step and principle-by-principle. The result is practical training... the kind of experience you can put to work in the marketplace.

PERSONALIZED TRAINING While some of our students have a working knowledge of electronics others are just getting started. That's why we have 10 career course levels from Basic to Advanced. They let you start where you want. Learn at your own pace. And learn as much as you like. You can even earn an Associate in Applied Science Degree in Electronics. And when you need help, our trained professionals are on hand to assist you by phone or mail.

Learning electronics isn't easy, but getting started is. For a CIE catalog and enrollment information, just mail the coupon below. Or call toll-free 1-800-321-2155. In Ohio, call 1-800-523-9109.

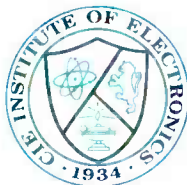

Accredited by the Accrediting Commission of the National Home Study Council, Washington, D.C.

CIRCLE 60 ON FREE INFORMATION CARD



YES! I want to get started. Send me my CIE school catalog including details about the Associate Degree program.

Print Name _____

Address _____ Apt. _____

City _____ State _____ Zip _____

Age _____ Area Code / Phone No. _____ / _____

Check box for G.I. Bulletin on Educational Benefits

Veteran Active Duty

MAIL TODAY!

CIE CLEVELAND INSTITUTE OF ELECTRONICS
1776 East 17th Street, Cleveland, Ohio 44114

ARE-101



Some courses feature the CIE Microprocessor Training Laboratory, an integral part of computers. You'll gain all the practical experience needed to work with state-of-the-art equipment of today and tomorrow.

EQUIPMENT REPORTS

Command Communications TF500 Autoswitch

Only one phone line is needed to automatically handle a fax, a computer, an answering machine, and a conventional telephone.



CIRCLE 48 ON FREE INFORMATION CARD

ADD UP THE MONTHLY CHARGES FOR all the telephone lines needed for the electronic gadgets used in the modern business office and you're looking at the reason why many smaller enterprises have avoided fax machines, computers, and even order-taking recorders.

But use a device called a TF500 Autoswitch, from Command Communications, Inc. (8000 E. Girard Ave., Suite 420, Denver, CO 80231) and, as shown in Fig. 1, you need only one telephone line to handle up to three office machines, as well as a telephone and its extensions.

A "Black box"

The TF500 Autoswitch, which is housed in a cabinet 6.87"W × 2.62"H × 6.37"D, is completely

automatic—there are no operating controls. On the rear apron are five telephone-type modular jacks labeled TELEPHONE LINE, PRIMARY ANSWER, PHONE, FAX, and AUXILIARY. (The AUXILIARY connector is usually used for a personal computer.) The front panel has LED indicators labeled ON, PRIMARY ANSWER, FAX, and AUXILIARY. The primary answer device is assumed to be a conventional telephone-answering machine.

The unit actually provides two automatic modes: one for "business hours," the other for "after hours," the primary difference being that it is assumed the telephone-answering machine will be turned off during business hours.

During business hours, the autoswitch assumes that the switch-

ing will be primarily between a telephone and a fax machine; hence, the autoswitch answers the call on the first ring and listens for the 1100-Hz tone that is transmitted by an *autodialing* fax machine. If it senses the tone, the TF500 connects the incoming call to the fax machine. If it does not sense the tone, the device rings on through to the local telephone five times. If the phone is not answered the autoswitch automatically switches in the fax, which transmits a "wake-up signal" that activates a non-autodialing originating fax.

Since the autoswitch actually answers the phone on the first ring and then takes a few seconds to decide whether the call is fax or phone, to prevent the caller from holding a "dead line" while the device makes up its mind, the TF500 generates a *phantom* ringing signal back to the caller. As far as the caller is concerned, he hears the telephone ringing—he does not know that the call has actually been answered. Because of the phantom ringing, the autoswitch is transparent to the user.

If a call is answered on the phone, and then it is decided that the caller needs a connection to the fax, or the to computer that is connected to the AUXILIARY jack, the call can then be switched manually to the desired equipment by simply entering the appropriate code on the local *Touch Tone* telephone.

Direct outgoing

Although the TF500 switches incoming calls, local equipment automatically seizes the phone line for outgoing calls and prevents interference from the other equipments. For example, if the local telephone goes off-hook, it is automatically connected to the telephone line. Similarly, if either

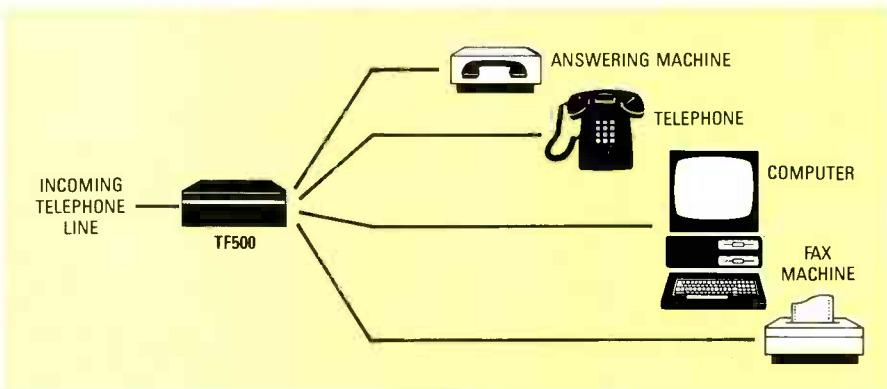

FIG. 1

the fax or the computer started, the first one activated seizes the phone line.

After hours

If an active telephone message machine is connected to the PRIMARY ANSWER jack after normal business hours, the caller can use *Touch Tones* to selectively switch the individual machines.

An incoming call automatically trips the message machine because it is connected to the PRIMARY ANSWER jack. Your message can instruct the user to simply start talking after the beep to leave a voice message, to press 1 to access the fax, or press 2 to access the computer. Since the system responds to *Touch Tones*, the caller can, at any time, over-dial an access code to branch either to the fax or the computer after leaving a voice-message on the answering machine.

Security

If there is some need for security the tone codes can be user-programmed so that only those people authorized to access the fax and computer can do so. For example, the autoswitch can be re-programmed so that the fax is accessed by the code 1234—rather than a 1, while the computer is accessed by the code 9876—rather than a 2. Also, there is no need to tell authorized persons that machine access is available. The telephone-answering machine can give a conventional "...speak when you hear the beep" message.

Seven features can be programmed by the user. They are the fax-access code, the auxiliary-ac-

cess code, the number of rings (1-4) before the autoswitch answers, the ring count (1-9) into the primary and phone port, the ring count (1-9) into the fax port, the ring count (1-9) into the auxiliary port, and a default to the factory settings.

The programming is done through a special connection, and the local *Touch-Tone* phone that is connected to the PHONE jack. First, the supplied modular cable is con-

nected between the TELEPHONE LINE jack and the PRIMARY jack. Then, autoswitch is placed in the programming mode by holding down the # key as the telephone's handset is lifted off-hook. After programming is completed, you exit by pressing the * key.

To use the autoswitch with the new coding, you simply reconnect the modular cable to the telephone jack. **R-E**



KIK®

Factory Direct
800-545-8784

Celebrating our 10th Year in U.S.A. . . .

Proven Quality . . .

Factory Direct Prices!

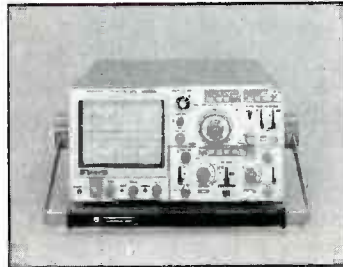

COS 5100: 100 MHz

- 3 Channel, 8 Trace
- P-P level-lock auto-trigger
- Delayed Sweep

Now Only
\$1399.00

COS 5042TM, 40 MHz **\$809.00**

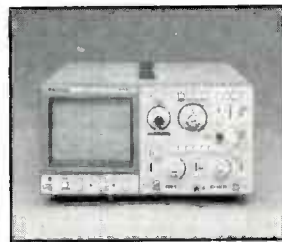

COS 5041TM

- 40 MHz, Delayed Sweep
 - 2 Channel
 - Ch 1 Signal Output
- \$709.00**

COS 5021TM

- 20 MHz, Delayed Sweep
 - 2 Channel
 - Ch 1 Signal Output
- \$529.00**

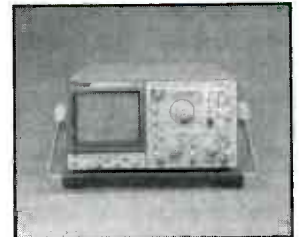

COS 5060TM

- 3 Channel, 8 Trace
- P-P level-lock auto-trigger
- Delayed Sweep

\$959.00

255 Frequency Counter:
150 MHz **\$299.00**

COS 5040TM

- 40 MHz
 - 2 Channel
 - CH 1 Signal Output
- \$659.00**

FC01130 Frequency
Counter: 1GHz **\$739.00**

677D Wow and Flutter
Meter **\$949.00**

COS 5020TM

- 20 MHz
 - 2 Channel
 - CH 1 Signal Output
- \$449.00**

6701 Wow and Flutter
Meter **\$999.00**



Add \$15 per unit shipping and handling.

(800) 545-8784

(213) 371-4662
Collect CA & AK

Local Service Centers
Nationwide



Kikusui International Corp.
19601 Mariner Avenue
Torrance, CA 90503

©Copyright Kikusui International Corp. 1988

CIRCLE 195 ON FREE INFORMATION CARD



OK — Quit the clowning around — what kind of experiment are you running today?

NEW PRODUCTS



CIRCLE 10 ON FREE INFORMATION CARD

HANDHELD MULTIMETERS.

Fluke's 80 Series comprises three models of low-cost, high-performance, 3¾-digit, sealed, handheld multimeters. In addition to the standard digital-multimeter functions, each offers a powerful combination of measurement functions—including frequency, duty cycle, capacitance, and simultaneous minimum/maximum/average recording—and safety features, such as MIN MAX alert, and Input Alert. All models—83, 85, and 87—feature a relative (zero) mode, as well as Touch Hold capability that beeps when it senses

a stable reading and locks it on the display for convenient viewing after the test leads are removed.

The minimum/maximum/average recording mode makes the 80 Series well-suited for finding intermittent failures and interference, and the audible MIN MAX Alert pinpoints intermittent failures by signalling the user with a short beep only when a new minimum or maximum value has been recorded. The Input Alert warns the user when the leads are connected to the current jack while the meter is selected for voltage or resistance.

The top-of-the-line Fluke 87's analog display is a high-resolution pointer that is updated 40 times per second. It can be back lit and has a user-selectable 4½-digit (20,000 count) mode, in addition to the 3¾-digit (4000 count) digital display. A true RMS multimeter, the 87 also features a Peak MIN MAX recording mode that is ideal for capturing transient events to 1 ms, or sinewave-plus or -minus peaks to 400 Hz.

The analog display on the Fluke 83 and 85 is a bar graph with zoom mode. The 83 has an AC-voltage response specified to 5 kHz, and DC-voltage accuracy within 0.3%. The Fluke 85 and 87 are even more accurate, extending AC voltage to 20 kHz and DC-voltage accuracy to within 0.1%.

All three 80 Series multimeters are EMI shielded, overload protected to 1000 volts in the resistance- and diode-test modes, and have patent-pending protection circuitry. Each comes in a carrying case with a protective holster that includes a flexible-rubber stand. That stand allows the meter to be hung from pipes or doors, or used as a normal tilt stand. They carry a three-year warranty.

The suggested list prices for the Fluke 83, 85, and 87, respectively, are \$189.00, \$219.00, and \$259.00.—John Fluke Mfg. Co., Inc., P.O. Box C9090, Everett, WA 98206; 800-443-5853, ext. 33.

PERSONAL SYNTHESIZER.

Breakaway Music Systems brings new meaning to the concept of a "one-man band" with the Vocalizer 1000. Simply by humming into the personal vocal synthesizer, you can convert the pitch of your voice into your choice of musical-instrument sounds—no musical ability is required. And,

with the unit's built-in multi-track digital recorder, you can record one part at a time and add them to the provided drum rhythms to compose a full song.

The "user-friendly" Vocalizer 1000 is controlled entirely by the human voice; it has no keyboard. An interactive demonstration is built in to the unit, and simple in-

structions appear on the LCD screen to prompt you at each step.

The versatile synthesizer lets you choose from 28 musical instruments, including electric piano, slap-bass guitar, flute, saxophone, trumpet, violin, bells, or steel drum. Special effects such as harmony, slide, chorus, and echo add dimension to your music. If you

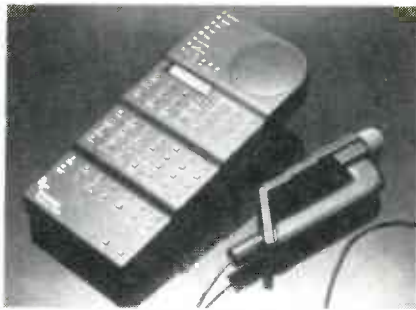

CIRCLE 11 ON FREE INFORMATION CARD

play a musical instrument, you can get even more out of the *Vocalizer 1000* through its audio input. Its MIDI capabilities allow the unit to be connected to professional keyboard synthesizers.

In addition, a full range of pre-programmed songs to jam along to—called *Smartsongs*—are included. (Additional plug-in Smartsongs cartridges are available separately.) Smartsongs styles include variations of rock, soul, jazz, Latin, blues, reggae, and country. "Voice-Guide" technology helps you hum notes that are in tune with the background Smartsongs music.

The compact unit weighs about three pounds, including batteries. It is powered by six C-sized batteries, or by a household-current adaptor.

The *Vocalizer 1000* has a suggested retail price of \$299.99.—**Breakaway Music Systems**, 1900 Norfolk Avenue, Suite 340, San Mateo, CA 94403.

DRAWING SOFTWARE. Drawing circuit schematics, circuit boards, robotic systems, and floor plans is easy with the *Microdesigner* soft-

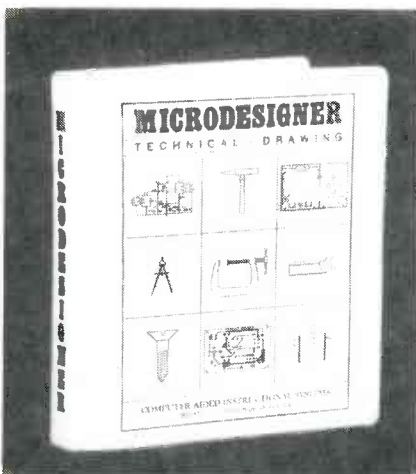

CIRCLE 12 ON FREE INFORMATION CARD

ware package from *Computer Aided Instructional Systems*. The fast, expandable, unprotected system requires 48K and one disk drive, and is compatible with the Apple II computer family.

Designed for anyone who requires a basic, inexpensive, and flexible drawing system, *Microdesigner* can be used to draw, plot, write text, print, erase, and create computer circles. Hundreds of technical symbols and shapes, pre-drawn by computer,

are included. Graphics can easily be saved and recalled.

Symbols can be rapidly rotated and positioned on the screen by using either keyboard or external controllers. The Koala Pad, joystick, or game paddles may be used as inexpensive and effective controllers.

Microdesigner, including an easy-to-use keyboard-menu card, complete user's manual, and one 5¼-inch diskette, sells for \$59.95 softcover, or \$69.95 hardcover.—

Joseph Electronics' 40th Anniversary Specials!

Special INSTRUMENT SALE!



Model 2120 Oscilloscope
DC to 20 MHz. Dual Trace, 6" CRT, 1mv Sensitivity.

Reg. \$520 **\$379.40**
40TH ANNIVERSARY PRICE

Model 2125 Oscilloscope
Same great features as 2120, except with delayed sweep.
Reg. \$620 **\$519.40**
40TH ANNIVERSARY PRICE

Model 1541A Oscilloscope DC to 40 MHz, Dual Trace, 6" CRT 1mv Sensitivity.
Reg. \$845 **\$739.40**
40TH ANNIVERSARY PRICE

Model 2160 Oscilloscope DC 60MHz, dual trace, delay sweep, 6" CRT, 1mv sensitivity.
Reg. \$995 **\$839.40**
40TH ANNIVERSARY PRICE

Model 2520 Digital Storage 20MHz, Dual Trace, 2mv Sens.
Reg. \$1990 **\$1795.40**
40TH ANNIVERSARY PRICE

Model 2521 Digital Storage 20MHz, Dual Trace CRT Readout, Cursors, RS232 Interface.
Reg. \$3050 **\$2745.40**
40TH ANNIVERSARY PRICE

Model 1249 NTSC/RGB Color Bar Generator. Composite Video Output, RF Output.
Reg. \$499 **\$419.40**
40TH ANNIVERSARY PRICE

Model 2009 MTS TV Stereo Generator Ideal for Stereo TV, Receivers, VCR's and Stereo Adapter Service.
Reg. \$499 **\$419.40**
40TH ANNIVERSARY PRICE

Model 2830 3 1/2 DIGIT LED BENCH Multimeter. 5 DCV Accuracy, ALL 33 Ranges and Functions are Push Button Selectable.
Reg. \$243 **\$209.40**
40TH ANNIVERSARY PRICE

Model 1045 Telephone Product Tester Provides Basic Operation Tests for Corded and Cordless Telephones, Answering Machines and Automatic Dialers.
Reg. \$495 **\$415.40**
40TH ANNIVERSARY PRICE

Model 1803 Frequency Counter 100 MHz, 8 digit display, zero blanking AC or Battery.
Reg. \$199 **\$169.40**
40TH ANNIVERSARY PRICE

Model 2005 RF Signal Generator 100 KHz to 150 MHz, in 6 fundamental bands and 450 MHz in harmonics.
Reg. \$195 **\$165.40**
40TH ANNIVERSARY PRICE

Model 3011 Function Generator 2 MHz, 4 digit display, TTL & CMOS pulse outputs.
Reg. \$239 **\$199.40**
40TH ANNIVERSARY PRICE

Model 1630 DC Power Supply 0-30V, 0-3A, high-low current range. Low ripple.
Reg. \$251 **\$209.40**
40TH ANNIVERSARY PRICE

Model 1601 DC Power Supply isolated 0-50V, 0-2A in ranges, fully automatic shutdown, Adj. current limit.
Reg. \$463 **\$389.40**
40TH ANNIVERSARY PRICE

Model 1650 Triple Output Power Supply two 0-25 VDC @ 5A and 5VDC @ 5A, fully automatic shutdown.
Reg. \$489 **\$409.40**
40TH ANNIVERSARY PRICE

Model 1653 AC Power Supply variable isolated 0-150 VAC @ 2A, built-in isolation transformer.
Reg. \$200 **\$169.40**
40TH ANNIVERSARY PRICE

NEW! Model 388-HD Hand-held 3 1/2 Digit LCD TEST BENCH

41 voltage ranges, frequency counter, capacitance meter, logic probe, transistor and diode tester. All packed into a drop-resistant case. **SPECIAL PRICE!**
Reg. \$139 **\$119.40**



We are celebrating our 40th Anniversary by offering you huge savings on B&K Test Equipment.

Send for FREE 480 page "Industrial Products Catalog." I understand it is FREE with any order or if requested on company letterhead. (Otherwise, \$4.95 to cover catalog and shipping costs.)

ORDER TOLL FREE
1-800-323-5925
IN ILLINOIS

312-297-4200
FAX: 312-297-6923

Joseph ELECTRONICS



JOSEPH ELECTRONICS, INC. Dept. R
8830 N. Milwaukee Ave., Niles, IL 60648

Rush merchandise per attached order. I understand rated accounts are shipped open account; otherwise send per credit card. Include \$5.00 per item for shipping and handling.

Visa Master Card Discover
 Check Money Order Rush Catalog

Card No. _____ Exp. Date _____

Name _____
Company _____
Street Address _____
City _____ State _____ Zip _____

IL Res. 7% Tax

Put Professional Knowledge and a
COLLEGE DEGREE
in your Technical Career through

HOME STUDY

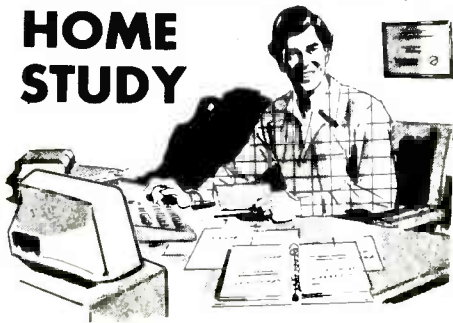

Add prestige and earning power to your technical career by earning your Associate or Bachelor degree through directed home study.

Grantham College of Engineering awards accredited degrees in
electronics and computers.

An important part of being prepared to *move up* is holding the right college degree, and the absolutely necessary part is knowing your field. Grantham can help you both ways—to learn more and to earn your degree in the process.

Grantham offers two degree programs—one with major emphasis in **electronics**, the other with major emphasis in **computers**. Associate and bachelor degrees are awarded in each program, and both programs are available completely by correspondence.

No commuting to class. Study at your own pace, while continuing on your present job. Learn from easy-to-understand lessons, with help from your Grantham instructors when you need it.

Write for our free catalog (see address below) or telephone us at (213) 493-4423 (no collect calls) and ask for our "degree catalog."

Accredited by
the Accrediting Commission of the
National Home Study Council

GRANTHAM
College of Engineering
10570 Humbolt Street
Los Alamitos, CA 90720

Computer Aided Instructional Systems, Box 177, Bldg. 5, Service Drive, Holly, MI 48442.

GOOSENECK MICROPHONE. Shure's Model SM99 miniature condenser microphone is designed for sound-reinforcement applications that require wide-frequency response and an unobtrusive appearance. Featuring a 1-cm precision condenser element and an on-board pre-amplifier, the gooseneck-mount microphone exhibits a symmetrical supercardioid polar pattern for excellent isolation and maximum gain before feedback. It comes with a pop filter that improves speech and musical pickup.

The SM99's 12-inch gooseneck has flexible sections at each end. Its center section is supported by an internal reinforcement system; with no bulky external-support tubes, the unit's sleek appearance is preserved.

Gooseneck microphones are generally favored for mounting on lecterns, pulpits, and conference

CIRCLE 13 ON FREE INFORMATION CARD

tables. With its extended frequency response and symmetrical-polar pattern, the SM99 can also be used for musical applications. Its ability to reject background noise makes it a good choice for picking up an instrumental soloist within an orchestra.

The SM99 accommodates a wide variety of mounting options. It can be plugged directly into any surface-mounted, 3-socket, XLR-type connector or permanently installed using the supplied mounting flange. Standard Shure swivel adapters can also be used to mount it on a conventional microphone stand.

The SM99 costs \$240.00.—Shure Brothers Inc., Customer Services Department, 222 Hartrey Avenue, Evanston, IL 60202-3696.

GRAY LINE SOFTWARE. MFJ's MFJ-1286 Gray Line DX Advantage/Terminator displays a detailed world map on IBM PC's and compatibles. It shows the moving Gray Line—the day/night dividing line—and the position of the sun over Earth.

The MFJ-1286 can be customized to display any 24 locations and the correct 12- or 24-hour time at each. Once started, it tracks Earth's



CIRCLE 14 ON FREE INFORMATION CARD

NEW SUPER LONG PLAY TAPE RECORDERS

12 Hour Model — \$105.00*
USES D-120 TAPE

Modified Panasonic Slimline, high quality, AC-DC Recorders provide 6 continuous hours of quality recording & playback on each side of cassette for a total of 12 hours.
Built-in features include:
• Voice level control. • Digital counter, etc. TDK DC 120 Cassette Furnished.



PHONE RECORDING ADAPTER

Records calls automatically. All Solid state connects to your telephone jack and tape recorder. Starts recording when phone is lifted. Stops when you hang up. \$24.95*
FCC APPROVED



VOX VOICE ACTIVATED CONTROL SWITCH
Solid state. Self contained. Adjustable sensitivity. Voices or other sounds automatically activate and control recorder. Uses either recorder or remote mike. \$24.95*
FCC APPROVED



*Add for ship & hdg. Phone Adapter & Vox \$1.50 ea. Recorders \$4.00 ea. Cal. Res. add tax. Mail order. VISA, M.C., COD's OK. Money Back Guarantee. Qty. disc. avail.. Dealer Inquiries Invited. Free data.
©
AMC SALES INC. Dept 9335 Lubec St., Box 928, Downey, CA 90241 Phone (213) 869-8519

CIRCLE 108 ON FREE INFORMATION CARD

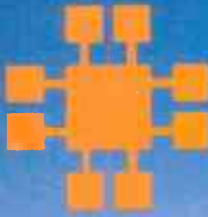

JDR INSTRUMENTS™

Complete customer satisfaction...superior service...friendly, knowledgeable personnel... quality merchandise...providing the best values in leading edge technology.

35 MHz OSCILLOSCOPE

A remarkable value

\$499⁹⁵

Wide bandwidth and exceptional 1mV/DIV sensitivity make the Model 3500 a powerful diagnostic tool for engineers or technicians at a remarkable price. Delayed triggering allows any portion of a waveform to be isolated and expanded for closer inspection. Variable Holdoff allows stable viewing of complex waveforms.

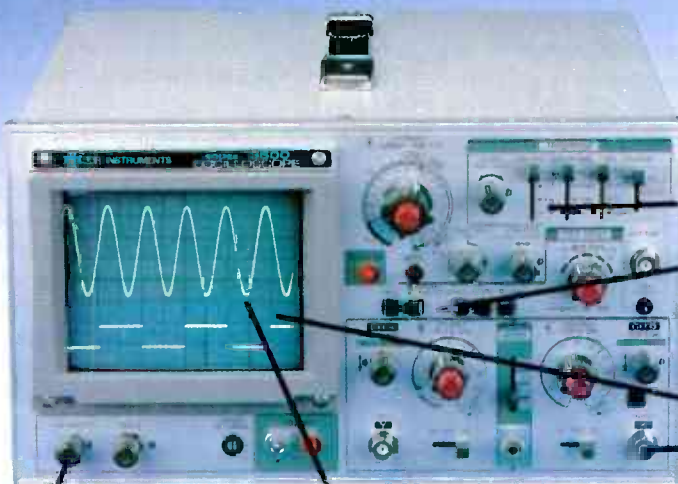

TV SYNC FILTER

DELAYED AND SINGLE SWEEP MODES

EXCEPTIONALLY BRIGHT 5" CRT

X-Y OPERATION

Z AXIS INTENSITY MODULATION

FAST IONS RISE TIME

DMM-300

\$79.95

3.5 DIGIT DMM/MULTITESTER

This full function 3.5 digit DMM offers highly accurate performance and a host of added features like audible continuity, capacitance, transistor, temperature, and conductance to help you do the job—fast. Temperature probe, test leads and battery included

- Basic DC accuracy: plus/minus 0.25%
- DC voltage: 200mv–1000V, 5 ranges
- AC voltage: 200mv–750V, 5 ranges
- Resistance: 200 ohms–20M ohms, 6 ranges
- Capacitance: 2000pf–20 μ f, 3 ranges
- Transistor Tester: 0^o–2000^oF
- Conductance: 200ns
- Fully overload protected
- Input impedance: 10M ohm

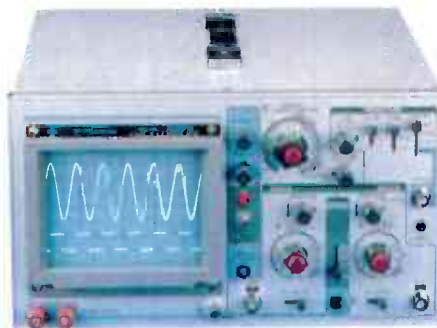

MODEL 2000

\$389.95

20 MHz DUAL TRACE OSCILLOSCOPE

Model 2000 makes frequency calculation and phase measurement quick and easy. The component tester aids in fast troubleshooting. Service technicians appreciate the TV Sync circuits for viewing TV-V and TV-H and accurate synchronization of the video signal, Blanking, VITS, and V/H sync pulses.

- Exceptionally bright 5" CRT
- Built-in component tester
- TV Sync filter
- X-Y operation \pm 110/220 volts

DMM-100

\$29.95

3.5 DIGIT POCKET SIZE DMM

Perfect for the field service technician. Shirt pocket size without compromising features or accuracy. Large, easy to read $\frac{1}{2}$ " LCD display. Fully overload protected for safety 2000 hour battery life with standard 9v cell. Probes and battery included.

- Basic DC accuracy: plus/minus 0.5%
- DC voltage: 2v–1000v, 4 ranges
- AC voltage: 200v–750v, 2 ranges
- Resistance: 2k ohms–2M ohms, 4 ranges
- DC current: 2mA–2A, 4 ranges
- Input impedance: 10M ohm
- Fully overload protected
- Approx. 5" x 3" x 1". Under 7 ozs.



DMM-200

\$49.95

3.5 DIGIT FULL FUNCTION DMM

Get highly accurate performance at a very affordable price. Rugged construction, 20 amp current capability and 22 ranges make it a perfect choice for serious field or bench work. Low battery indicator and tilt-stand. Probes and 2000 hour battery included.

- Basic DC accuracy: plus or minus 0.25%
- DC voltage: 200mv–1000V, 5 ranges
- AC voltage: 200mv–750V, 5 ranges
- Resistance: 200 ohms–20M ohms, 6 ranges
- AC/DC current: 200 μ A–20A, 6 ranges
- Input impedance: 10M ohm
- Fully overload protected
- Approx. 7" x 3 $\frac{1}{2}$ " x 1 $\frac{1}{2}$ ". Wt. 11 ozs.

DPM-1000

\$54.95

3.5 DIGIT PROBE TYPE DMM

Custom 80 pin LSI chip provides accuracy and reliability in such a compact size. Autoranging, audible continuity and data hold feature help you pinpoint the problem quickly. Case and batteries included.

- Basic DC accuracy: plus/minus 1%
- DC voltage: 2v–500v, autoranging
- AC voltage: 2v–500v, autoranging
- Resistance: 2k ohms–2M ohms, autoranging
- Fully overload protected
- Input impedance: 11M ohm
- Approx 6 $\frac{1}{2}$ " x 1" x $\frac{3}{4}$ ". Under 3 ozs.



- ★ 2 YEAR REPLACEMENT WARRANTY
- ★ 30 DAY MONEY BACK GUARANTEE
- ★ TOLL FREE TECHNICAL SUPPORT
- ★ NEXT DAY AIR SHIP AVAILABLE

JDR INSTRUMENTS, 110 KNOWLES DRIVE, LOS GATOS, CA 95030
RETAIL STORE: 1256 SOUTH BASCOM AVE, SAN JOSE, CA (408) 947-8881

ORDER TOLL FREE 800-538-5000

COPYRIGHT 1987 JDR MICRODEVICES

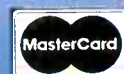

CIRCLE 59 ON FREE INFORMATION CARD

When performance & price really count...



Reliability & Quality
From Start To Finished Product

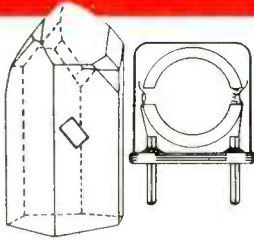

**QUARTZ
CRYSTALS/OSCILLATORS FOR
ELECTRONIC — INDUSTRIAL**

- Micro-Processor Control
- Computers/Modems
- Test/Measurement
- Medical

COMMUNICATIONS — REPLACEMENT

- Mobile/2-way/Channel Elements
- Pagers
- Marine
- Aircraft
- Telemetry
- Monitors/Scanners

AMATEURS

- CB
- Hobbies
- Experimenter

COST EFFECTIVE
MODERATE PRICING
FAST DELIVERY



Replacement Crystals Catalog
Custom Made Crystals Catalog

The Pulse of Dependable Communications

Crystek Crystals offers their new 16 page **FREE** catalog of crystals and oscillators. Offering state-of-the-art crystal components manufactured by the latest automated technology. Custom designed or "off the shelf." Crystek meets the need, worldwide. Write or call today!

CRYSTEK CORPORATION
DIVISION OF WHITEHALL CORPORATION

2351/2371 Crystal Dr. • Ft. Myers, FL 33907
P.O. Box 06135 • Ft. Myers, FL 33906-6135
TOLL FREE 1-800-237-3061
(813) 936-2109 — TWX 510-951-7448



CIRCLE 187 ON FREE INFORMATION CARD

movement, showing the Gray Line and sun positions changing as time passes. The high-speed display mode permits users to set any date and time, and watch solar/Gray Line positions change in increments of 2 minutes, 6 minutes, 1 hour, 1 day, or 1 week.

The *Gray Line DX Advantage/Terminator* works with virtually all graphics cards, including composite, Hercules, CGA, and EGA. It can be run alone, or memory resident with other software. It comes with a land-mass map, a latitude/longitude map, and a map that displays the 24 time-zone divisions. CGA works with the land-mass map, and allows users to send the display to a printer.

The *MFJ-1286 Gray Line DX Advantage/Terminator* costs \$29.95.—**MFJ Enterprises Inc.**, P. O. Box 494, Mississippi State, MS 39762.

SMT TRIALS KIT. The *SMT-K1*, kit from *OK Industries*, enables those who work with surface-mounted devices to evaluate, practice, or



CIRCLE 15 ON FREE INFORMATION CARD

learn SMT assembly, production, or rework techniques.

The kit includes a full range of surface-mounted components, including capacitors, transistors, PLCC's, and 100-pin gull-wing flat packs. The *SMT-K1* also contains a trial board designed to accommodate the wide variety of components. The board and components come in a conductive tray to prevent static and provide storage.

The suggested list price for the *SMT-K1* kit is \$64.95.—**OK Industries Inc.**, 4 Executive Plaza, Yonkers, NY 10701; 800-523-0667.

AUTOMATIC LEVEL CONTROLLER. *C & S Electronics Leveller* module automatically maintains the volume level of amateur, CB, marine radios, and scanners. It keeps the volume constant, regardless of incoming-signal strength.

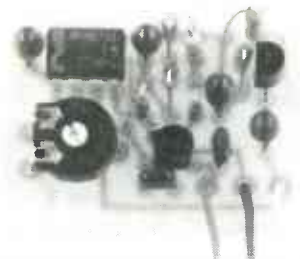

CIRCLE 16 ON FREE INFORMATION CARD

When using the *Leveller*, the receiver's volume level remains independent. The user sets the volume to a comfortable level, and the *Leveller* locks in that setting. The module draws less than 10 mA.

With only three wires to connect, installation is very simple. The module, measuring only 1¼ × 1½ × ½ inches, can be secured into any available space inside the set. Adhesive foam backing is supplied for mounting the module.

The *Leveller* costs \$24.95.—**C & S Electronics**, P. O. Box 2142, Norwalk, CT 06852.

R-E

Get A Complete Course In

**ELECTRONIC
ENGINEERING**

8 volumes, over 2000 pages, including all necessary math and physics. 29 examinations to help you gauge your personal progress. A truly great learning experience.

Prepare now to take advantage of the growing demand for people able to work at the engineering level.

Ask for our brochure giving complete details of content. Use your free information card number, or write us directly. **\$99.95**, Postage Included. Satisfaction guaranteed or money refunded.



**Banner
Technical
Books, Inc.**

1203 Grant Ave.
Rockford, IL 61103

CIRCLE 183 ON FREE INFORMATION CARD

Learn to troubleshoot and service today's computer systems as you build a fully XT-compatible micro, complete with 512K RAM and powerful 20 meg hard drive

NEW!
Includes
20 meg
hard drive!

Your NRI computer training includes all this: • NRI's unique Discovery Lab® for circuit design and diagnosis • NRI's hand-held digital multimeter featuring "talk-you-through" instructions on audio cassette • A digital logic probe that lets you visually examine computer circuits • The new Packard Bell VX88 computer with "intelligent" keyboard, 360K double-sided, double-density disk drive, 512K RAM, 16K ROM • 20 megabyte hard disk drive • Bundled software including MS-DOS, GW-BASIC, word processing, spreadsheet, and database programs • Packard Bell reference manuals with programming guidelines and schematics.



Train the NRI Way— and Earn Good Money Servicing Any Brand of Computer

Jobs for computer service technicians will almost double in the next 10 years according to Department of Labor statistics, making computer service one of the top 10 growth fields in the nation.

Now you can cash in on this exciting opportunity—either as a full-time industry technician or in a computer service business of your own—once you've mastered electronics and computers the NRI way.

NRI's practical combination of "reason-why" theory and hands-on building skills starts you with the fundamentals of electronics, then guides you through more sophisticated circuitry all the way up to the latest advances in computer technology. You even learn to program in BASIC and machine language, the essential language for troubleshooting and repair.

Get Real-World Skills as You Train With a Powerful XT-Compatible Micro—Now With 20 Meg Hard Drive!

To give you hands-on training with the absolute in state-of-the-art computer technology, NRI includes the powerful new Packard Bell VX88 computer as the centerpiece of your training. As you assemble this fully IBM XT-compatible micro from the keyboard up, you actually see for yourself how every section of your computer works.

You assemble and test your computer's "intelligent" keyboard, install the power supply and 5¼" disk drive, then interface the high-resolution monitor. But that's not all.

Your hands-on training continues as you install a powerful 20 megabyte hard disk drive—today's most-wanted computer

peripheral—now included in your course to dramatically increase the data storage capacity of your computer while giving you lightning-quick data access. Plus you work with exclusive word processing, database, and spreadsheet software, yours to use for your own professional and personal applications.

As you build your computer, performing key demonstrations and experiments at each stage of assembly, you get the confidence-building, real-world experience you need to work with, troubleshoot, and service today's most widely used computer systems.

No Experience Needed, NRI Builds It In

This is the kind of practical, hands-on experience that makes you uniquely prepared to take advantage of today's opportunities in computer service. You learn at your own convenience in your own home.

No classroom pressures, no night school, no need to quit your present job until you're ready to make your move. And all throughout your training, you've got the full support of your personal NRI instructor and the NRI technical staff, always ready to answer your questions and help you whenever you need it.

FREE 100-Page Catalog Tells More

Send today for NRI's big, 100-page, full-color catalog that describes every aspect of NRI's innovative computer training, as well as hands-on training in robotics, video/audio servicing, electronic music technology, security electronics, data communications, and other growing high-tech career fields. If the coupon is missing, write to: NRI School of Electronics, McGraw-Hill Continuing Education Center, 3939 Wisconsin Avenue, Washington, DC 20016.

IBM is a registered trademark of International Business Machines Corporation

SEND COUPON TODAY FOR FREE NRI CATALOG!

NRI

McGraw-Hill Continuing Education Center
3939 Wisconsin Avenue, NW, Washington, DC 20016



For Career courses approved under G1 Bill
check for details.

- CHECK ONE FREE CATALOG ONLY
- | | | |
|--|---|--|
| <input type="checkbox"/> Computer Electronics | <input type="checkbox"/> Electronic Design Technology | <input type="checkbox"/> Air Conditioning, Heating & Refrigeration |
| <input type="checkbox"/> TV/Video/Audio Servicing | <input type="checkbox"/> Industrial Electronics | <input type="checkbox"/> Small Engine Repair |
| <input type="checkbox"/> Robotics | <input type="checkbox"/> Communications Electronics | <input type="checkbox"/> Electrician |
| <input type="checkbox"/> Electronic Music Technology | <input type="checkbox"/> Basic Electronics | <input type="checkbox"/> Locksmithing & Electronic Security |
| <input type="checkbox"/> Security Electronics | <input type="checkbox"/> Bookkeeping and Accounting | <input type="checkbox"/> Travel Careers |
| <input type="checkbox"/> Digital Electronics Servicing | <input type="checkbox"/> Building Construction | <input type="checkbox"/> Telephone Servicing |
| | <input type="checkbox"/> Automotive Servicing | <input type="checkbox"/> Paralegal |

Name (Please print) _____

Age _____

Street _____

City/State/Zip _____

We'll give you tomorrow.

Accredited by the National Home Study Council

3-108

HARDWARE HACKER

A cheap color fuser

I HAVE FOUND SEVERAL ADDITIONAL sources for the low-cost telephone-coupling transformers that will be needed for the data-access arrangement circuits we looked at a few columns back.

In particular, check out the TXTS transformer from *All Electronics* at \$2.50 each, or any of bunches of different offerings from the PREM Magnetics folks.

A new transformerless telephone interface did appear way back in the October 1981 issue of *QST*. The circuit shown was rather complex. It also had to be custom-adjusted to suit each individual phone line.

Some details on an all-Canadian approach to our \$10 Navicube are available from Richard Langley of the *Geodetic Research Laboratory*. They also have some publications on navigation satellite-positioning systems available for you.

Apparently the all time numero uno super whiz bang expert of the earlier Navicube stuff is one Doug Garner at NASA. Check out all his superb construction projects in *Sport Aviation* magazine, starting in the late 1970's.

Of all of the Hardware Hacker topics ever, the \$10 Navicube stuff sure produced the greatest number of the most interesting phone calls and letters from some of the most creative hackers around.

More on the Navicube drama as it unfolds.

As per usual, this is your column and you can get tech help and off-the-wall networking by way of that *Need Help?* box. Please also note the *Names and Numbers* sidebar

A cheap color fuser mod
Omicrom and Kroy Kolor
More on the \$10 Navicube
Television on a RGB monitor
Industrial and trade resources

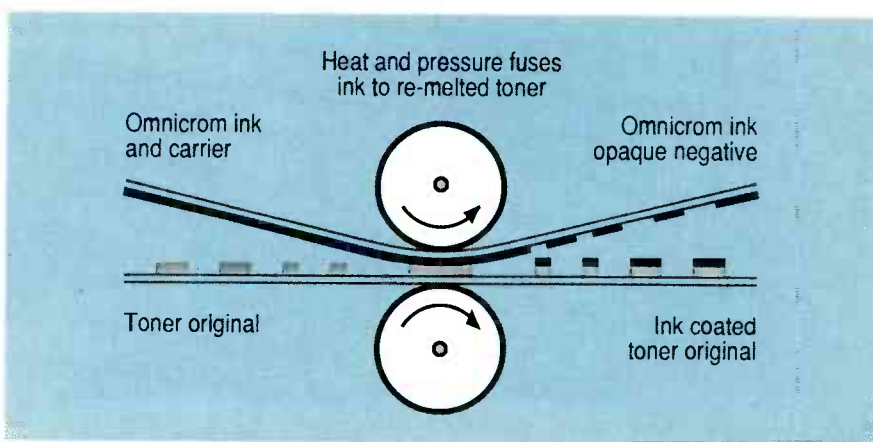

FIG. 1—THE OMNICROM PROCESS rapidly converts any toner-based copier or laser-printed image into full color in any of dozens of metallic, matte, or special-effect shades. Kroy Sign Systems now licenses the British Omnicrom process under the US tradename of Kroy Kolor.

that shows where you can go for more information on the sources mentioned.

This month, we'll look at some graphic-art electronics...

Omicrom and Kroy Kolor

For years, I've had a back-burner project going. The idea was to take an ordinary Xerox copy and run it through a magic machine where real ink would somehow stick only where the toner existed.

Obvious uses would be to get truly dense blacks, to be able to create "litho"-quality images for

printed circuits, overheads, or for electronics artwork, to gain total color options, and to provide a durable "raised ink" thermography process, for letterheads, for custom business cards and even for use when printing in Braille.

It turned out that an English outfit by the name of *Omicrom* beat me to the punch. As Fig. 1 shows us, Omnicrom reasoned that toner was really a mixture of black stuff and hot glue. You could think of a copy as a piece of paper that had hot glue selectively placed only where you wanted it.

By putting a dry-ink based carrier in contact with the Xerox copy and applying heat and pressure, the toner would remelt and grab the dry ink off the carrier sheet.

Presto: The instant conversion of copier or laser-printed output into brilliant metallics or bright mattes, silvers, golds, a solid black, and even some pearl effects.

NEED HELP?

Phone or write your **Hardware Hacker** questions directly to:

Don Lancaster
Synergics
Box 809
Thatcher, AZ 85552
(602) 428-4073

- 1 - Canon F21680 Fusion machine using a FH1-0576-01 temperature pc card.
- 1 - 25K linear volume control
- 1 - 150K, 1/2 watt resistor
- 1 - Dialplate decal
- 1 - Dialplate decal overlay
- 1 - Push-on knob with pointer

Misc: 12 inches of red solid #22 hookup wire; 12 inches of similar green wire; 12 inches of similar black wire; 8 inches of solder; two 3/8 inch volume control nuts; 1 flat volume control washer; 1 internal tooth volume control lockwasher.

Note: One source of the Canon fusion machines, parts kits, and modified and tested units is Arlin Shepard at Lazer Products, 12741 E. Kaley Avenue, Suite #130, Englewood CO, 80111. (303) 792 5277.

G. 2—THE PARTS REQUIRED to modify Canon F2160 fusion machine for variable-temperature operation.

Along with a unique shiny high-gloss varnish or even true laminating for scuff-resistant menus or book covers.

As a bonus, the carrier sheet can

also become an "instant negative," useful for such things as overhead transparencies. If you wanted to, you could even reuse any remaining portion of any carrier as often as you liked.

But there were serious problems. The Omnicrom people were British and monumentally mis-managed all of their marketing efforts in "the colonies." Their ear-

ly materials weren't all that reliable. Worst of all, they saw nothing unconscionable about the charging of over \$1400 for a "fusion machine" that was nothing but a pair of warm rollers that turned.

A few years ago, the *Kroy Kolor* people did become an Omnicrom licensee and then dramatically improved all the materials, added more colors and options, and

- () Verify that the unit to be modified is in fact a Canon F21680 machine and then unplug the line cord from the AC outlet.
- () Remove the center lid by raising the green handle and removing the two black screws at the rear and the two silver screws on the inside. Be gentle!
- () Remove the right cover by removing the two silver screws at the rear, the black screw at the right bottom, and the black screw at the front bottom. Again, be gentle!
- () Cover the temperature decal with a similar sized clear self-stick overlay. Neatly trim the decal to just outside the black border.
- () Clean the front of the right cover and apply the temperature decal so it is 3/8 of an inch in and 3/8 of an inch up from the lower lefthand corner. (See Figure five)
- () Drill a 13/32 inch hole at the crosshairs on the temperature decal. This is easiest to do with a Vise Grip UNIBIT, but a pilot hole and reamer can be used instead. Deburr the hole.
- () Mount the volume control in the hole. Use a nut and lockwasher behind the panel and a nut and flat washer in front of the panel, adjusting for the flushest possible mounting.
- () Solder the 150K resistor to the center lug of the volume control, keeping the lead both reasonably short and mechanically strong. (See Figure six)
- () Form a loop in the free end of the resistor and trim the lead. Strip 1/4 inch off of both ends of the green wire and solder one end to this resistor loop. (See Figure six)
- () Strip 1/4 inch off both ends of the black wire and solder it to the leftmost lug of the volume control when viewed from the rear bottom. (See Figure six)
- () Strip 1/4 inch off both ends of the red wire and solder it to the rightmost lug of the volume control when viewed from the rear bottom. (See Figure six)
- () Twist all three wires tightly together for all but the last inch of their length.
- () Unplug the black and white motor connector from the innermost circuit board. Unplug the two heavy red wires from the motor speed sensing power resistor.
- () Remove the three large Phillips screws that hold the circuit boards in place. You may have to restrain the white circuit board spacers to keep them from turning when you do this.
- () Slide the two circuit boards out where you can work on them. You may have to work up some slack in the yellow thermistor wires. Unplug the five pin black and blue connector.
- () Verify that the yellow thermistor wires go to a FH1-0576-01 printed circuit board.
- () Route the twisted black, red, and green wire between the motor starting capacitor and the motor control power triac. Then route it along the yellow wire, through the small hole, and over to the FH1-0576-01 printed circuit board.
- () Loop and solder the black wire to the inside end of diode D303. (See Figure six)
- () Loop and solder the green wire to the outside end of resistor R307.
- () Loop and solder the red wire to the outside end of diode D304.
- () Replace both circuit boards, the three large Phillips screws, the black and white motor connector, the two red power resistor wires, and the blue 5 pin connector. Redress the yellow thermistor leads back the way they were.
- () Verify that the right cover can go back on without pinching any wires and that there are no wires anywhere near the large gear or other moving parts.
- () Verify that all connectors and wires are now secure.
- () Replace the right cover and the lid using the original screws.
- () Press the knob onto the volume control shaft, being certain that the pointer points straight up to NORMAL when at the center of its rotation range.
- () Refer to the text for the checkout procedure.

FIG. 3—A SURPLUS CANON FUSION MACHINE can replace an Omnicrom or Kroy Kolor machine at a tiny fraction of the cost, after this 60-cent modification is made.

NEW FROM DON LANCASTER

HANDS-ON BOOKS

ASK THE GURU Reprints	24.50
MOS Cookbook	18.50
TL Cookbook	16.50
Active Filter Cookbook	15.50
Micro Cookbook vol I or II	16.50
Enhancing your Apple v. I or II	15.50
Applewriter Cookbook	19.50
Apple Assembly Cookbook	21.50
Credible Secret Money Machine	10.50
PostScript Cookbook (Adobe)	16.50
PostScript Ref. Man. (Adobe)	22.50
PostScript Prog. Man (Adobe)	22.50

UNLOCKED SOFTWARE

PostScript Show & Tell (Ile/Mac/PC)	39.50
Pro to Postscript VHS Video	39.50
PostScript Perspective Draw	39.50
PostScript Printed Circuits	39.50
PostScript Technical Illustrations	39.50
Postscript BBS stuff	19.50
Resolute Reset Ile & Ilc	19.50
Applewriter/Laserwriter Utilities	49.50
Apple Ram Card Disassembly Script	24.50
Apple II or II Companion Disk	19.50
Applewriter CB or Assy CB Disk	24.50

FREE VOICE HELPLINE VISA/MC

SYNERGETICS
Box 809-RE
Thatcher, AZ 85552
(602) 428-4073

Circle 83 ON FREE INFORMATION CARD

NAMES AND NUMBERS

All Electronics Corp

PO Box 567
Van Nuys, CA 91408
(800) 826-5432

Avantek

3175 Bowers Avenue
Santa Clara, CA 95054
(408) 727-0700

Computer Shopper

Box F
Titusville, FL 32781
(305) 269-3211

Doug Garner

NASA Langley MS 471
Hampton, VA 23665
(804) 827-3321

Geodetic Research Laboratory

University of New Brunswick
PO Box 4400
Fredericton, NB E3B 5A3
(506) 453-4698

W.W. Granger

5959 West Howard Street
Chicago, IL 60648
(312) 647-8900

Kroy Kolor

14555 N. Hayden Road
Scottsdale, AZ 85260
(602) 951-1593

Lazer Products

12741 E. Kaley Ave., S130
Englewood, CO 80111
(303) 792-5277

McMaster-Carr

Box 54960
Los Angeles, CA 90054
(213) 692-5911

MuRata-Erie

2200 Lake Park Drive
Smyrna, GA 30080
(404) 436-1300

National Semiconductor

2900 Semiconductor Drive
Santa Clara, CA 95052
(408) 721-5000

NEC Electronics

401 Ellis Street
Mountain View, CA 94039
(415) 960-6000

Nuts & Volts

Box 1111
Placentia, CA 92670
(714) 632-7721

Omicrom

Tonge Bridge Way
Bolton, Lancashire BL2 6BD
UNITED KINGDOM
0204 392050

PREM Magnetics

3521 N. Chapel Hill Road
McHenry, IL 60050
(815) 385-2700

Small Parts

6891 NE Third Avenue
Miami, FL 33138
(305) 751-0856

Unitrode

7 Continental Blvd.
Merrimack, NH 03054
(603) 424-2410

United States Plastic Corp

1390 Neubrecht Road
Lima, OH 45801
(408) 559-7778

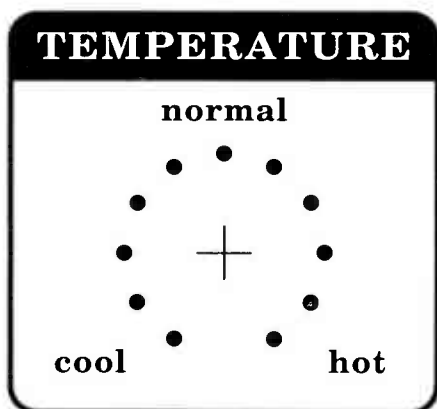

FIG. 4—FULL-SIZE ARTWORK for the front-panel decal.

made them much easier to get. They also improved and modestly lowered the selling price of the fusion machines.

You can get several no-charge evaluation samples just by calling Randy Bailey over at Kroy. They also do have lots of sign-building accessory kits and heavier printing stocks.

But, judging from the *Perrier* in all of their corporate birdbaths, Kroy appears to be a company of, by, and for Yuppies. "Low-end user cost" just is not presently in their vocabulary. If you do not own a BMW, they do not appear to want you as a customer.

So, it might still take a while be-

fore some genuine competition can drive the end-user costs down to the nickel-a-sheet mass market range where they belong.

Kroy Kolor is a fantastically great product when and where its sixty cents or so per sheet cost can be justified. This product totally revolutionizes what you can do with a copier or a laser printer. The sad thing is that it could do so much more if only it were sanely priced.

Meanwhile, though, the quest goes on for...

A cheap Omicrom fuser

You do not need \$1400 to use Omicrom or Kroy Kolor. All you need is heat and pressure.

For instance, a plain old iron and a muslin pressing cloth will do the job just fine. You can also use the existing fusion rollers inside your laser printer or copier, by making a second pass while hand-feeding a blank page. The process works best with the metallic colors; but you might occasionally get a mis-feed, wrinkles, or dropouts.

A few of the newest copiers are set up to directly use Kroy Kolor.

One trick that works well and dramatically drops the price is to use spot color. For instance, on a letterhead, you tape a small piece of Kroy Kolor applied only to the logo and then run it back through the printer. Be sure to use a very

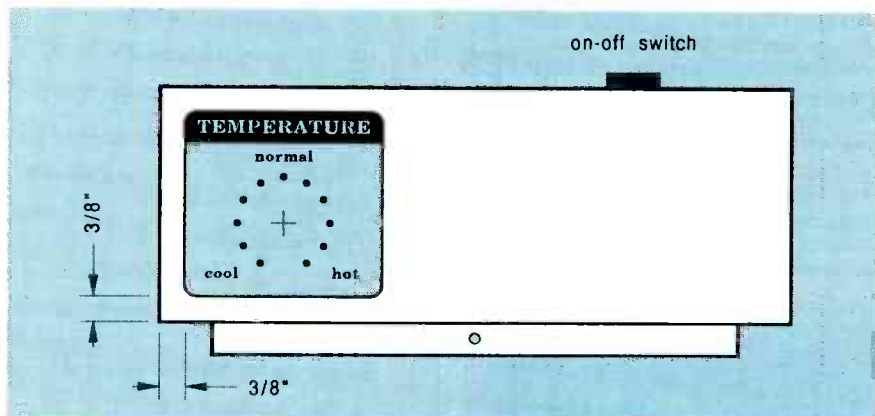

FIG. 5—POSITION THE DECAL exactly as shown here onto the front skirt of the right cover. A $\frac{1}{32}$ -inch hole is then drilled at the crosshairs.

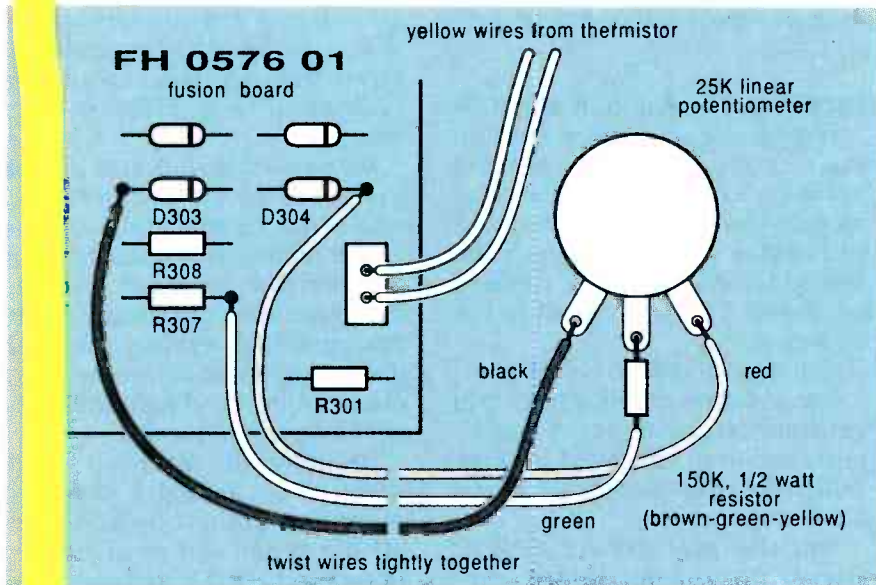

FIGURE 2—THE PICTORIAL DIAGRAM for the Canon fuser unit modification. The modification costs around 60 cents and can be done in twenty minutes.

lock tape, such as the Scotch *Post-It Cover Up Tape*, available at your local office supply.

But there is a better way. It turns out there is a wondrously bizarre machine widely available today on the surplus market called a *F21680 Canon Fuser Unit*.

Everybody (especially all of those Canon dealers!) had even the slightest idea what those machines were for or how to use them, so they were all dumped at fire-sale prices. Rumor has it that the machines were somehow involved in making color overhead transparencies.

In any rate, the only difference between a real Omnicrom fusion machine and a Canon fuser unit is around 5:1 in cost and the fact that the stock Canon fuser machine was set to a fixed and somewhat low temperature.

Fortunately, sixty cents worth of parts and twenty minutes work will convert the Canon unit into a beast that actually will outperform the Omnicrom machine and do so at a tiny fraction of the cost.

The super-rugged Canon unit gives better results because of a slower feeding speed and some self-cleaning roller-wiper pads. It works especially well with the SX toner cartridges, such as from an Apple LaserWriter NT or NTX.

The only little problem I have found with the modified unit is that you have to trim your laminating film to a maximum width of

8-1/2 inches. Kroy's *Color Plus* machine shares that same problem.

Figure 2 shows you a parts list for that modification. Figure 3 gives you detailed instructions. Figure 4 is a full-size replica of the new dial decal, while Fig. 5 shows you where to position the decal on the front of the machine. Finally, Fig. 6 is a pictorial for the modification.

The fusion unit does its thing by comparing a thermistor resistance against a fixed-voltage reference. The modification lets you raise or lower that internal reference by sourcing or sinking a slight amount of extra current.

The temperature range is set by that new 150K resistor. A higher value *restricts* the range, while a lower one *extends* it. A half-watt resistor was chosen because it is physically stronger than a quarter-watt one.

The checkout procedure is fairly simple. Center your new temperature control and then apply the power. The panel LED should start blinking a dim green and the internal fusion lamp should come on. After one minute, the fusion lamp should go out and the LED should change to a bright and continuous green.

Advance the temperature control clockwise by one quarter of a turn. The fusion lamp should come on for three or four seconds and then shut back off.

Retard the temperature control fully counterclockwise and wait a

few minutes. Eventually the fusion lamp should come back on for a few seconds. When the lamp goes back off, advance the control by one quarter turn. The fusion lamp should go back on again for a few seconds and then shut down.

If all of those tests are passed, center the temperature control and try a metallic Kroy Kolor sheet. Use a "normal" setting for metallic foils, a somewhat higher setting for the matte colors, and a slightly lower setting for the laminating film.

Here's another tip: If you run a toner copy through the machine in contact with a thin sheet of polyester "Mylar" film or by using an "empty" Kroy Kolor carrier, your copy will *Bakerize*, giving you a more durable, blacker, and a semi-gloss finish. That is handy for such things as quick and dirty business cards, and is a zero-cost process.

Among the many other sources, surplus Canon fuser units are now available by way of Arlin Shepard over at *Lazer Products*.

Modification kits and the fully modified and tested units are also available, at a tiny fraction of the current cost of the real Omnicrom fusion machines.

Getting plain old stuff

In addition to all of the usual electronic components, most all of you hardware hackers also need good sources of the plain old everyday things needed to develop all your ideas and to put those electronic components together. Things like tools and hardware, raw material stock, electrical items, plastics, and all of the many other oddments that seem to go along with serious hacking.

I have found four outstanding sources for that sort of thing.

First, check into the *McMaster-Carr* supply people. See if you can't cop one of their 2000+ page catalogs that is jam-packed with tools, materials, hardware, plastics, and just about everything else that's "industrial" in nature.

Second, the really great *W.W. Granger* catalog covers just about everything electrical—for motors, pumps, controls, wire, accessories, and so on. While those folks have branches in most larger cities, you often may need a trade

name and a tax stamp to be able to do business with them.

Third is *Small Parts*. Besides a mind-boggling stock of robotic and electronics hardware, they also will custom cut metals and plastics for you in small quantities.

And, fourth, for plastics, do look into the *United States Plastic Corp* who have an incredible variety of plastic materials available.

If you do have any similar "just stuff" favorites, how about letting me know so we can then share those resources with the others?

In fact, let's make a contest out of it. Your entry must begin with the words "A great source for neat stuff is....," and there will be all of the usual *Incredible Secret Money Machine* book prizes, along with an all-expense paid (FOB Thatcher, AZ) *tinaja quest* for two for the best entry of all.

If possible, include a flyer or a catalog with your entry. You'll get extra points for especially obscure or off-the-wall sources. Please send the entries directly to me per the "Need Help?" box, and not to

the *Radio-Electronics* editorial-staff offices.

Receiving TV on a RGB monitor

I've gotten a bunch of calls on that recently. You've just spent big bucks on a high-quality RGB color monitor for your computer, and you realize that it sure would be nice to be able to receive cable or off-the-air TV on it to justify the high cost.

Can that be done?

The answer is "Well, sort of." To get from off-the-air TV to a computer monitor, you need a tuner, an IF strip, an audio processor, and a video detector.

You also may require a NTSC (Never The Same Color) composite-video-to-RGB converter as well, if the monitor doesn't accept a composite-video input.

The circuitry needed, its design, and its alignment are far too complex to throw together on your own out of individual components. You also would be largely reinventing the wheel.

Sadly, I know of no "plug-and-

go" adaptor that you can buy, but that is an obvious product that someday should appear at *Federated*, or at *Radio Shack* or wherever.

My personal solution to that was to go with the old *Sony KV1311-CR* which is a combination receiver and monitor that actually is lots cheaper than many of the other RGB monitor-only products. But that particular receiver can't handle the higher horizontal-scan frequencies involved with some Mac or IBM graphics modes.

For now, the best bet would seem to be to find a junked or otherwise trashed-over VCR and lift the tuner and receiver electronics out of it. Or perhaps do the same things to a conventional TV set that has problems with the picture tube or possibly the deflection circuitry.

Yeah, that is kind of a wimpy answer. Let me know if you come up with a better one. That is also an ideal topic for some future *Radio-Electronics* construction project.

continued on page 80



Cut Your Video Servicing Time By 54%

With the Market Proven VA62 Universal Video Analyzing System.

Today's VCRs, TVs, and MTS Stereo TVs require a proven method to quickly isolate the defective component. New technology has made simple problem solving a time-consuming and expensive procedure.

A survey of over 1500 Video Analyzer owners has shown that the VA62's unique signal substitution method has reduced their video servicing time by an average of 54%, and increased their servicing profits.

You can join the successful service centers that have cut their video servicing time and increased their profits with the VA62 Universal Video Analyzing System. Call for a brochure on the VA62. Call **1-800-843-3338**, and increase your profits. In Canada Call **1-800-851-8866**.

SENCORE

3200 Sencore Drive, Sioux Falls, SD 57107

100% American Made

CIRCLE 185 ON FREE INFORMATION CARD

Heathkit®

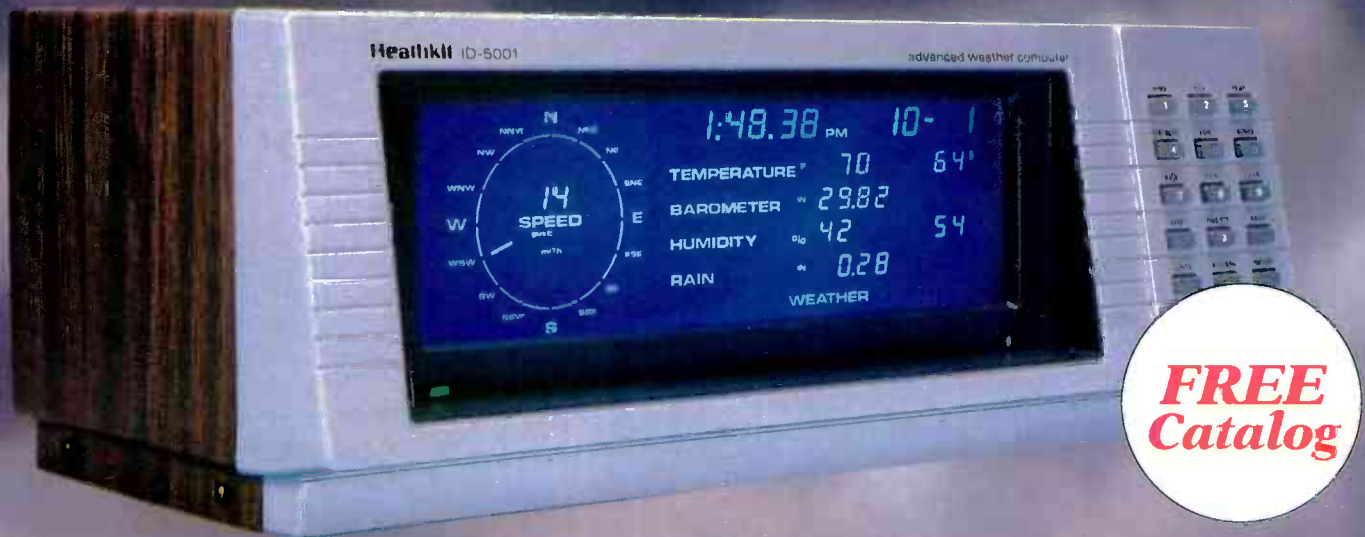

Track The Weather With Your Own Personal Weather Station

Don't let the weather catch you off guard. Plan your activities using the precision-crafted Heathkit® ID-5001 Advanced Weather Computer.

Powerful enough for commercial use, the ID-5001's striking cobalt blue liquid crystal display indicates wind speed, humidity, rainfall, high and low temperatures, and more. You'll find at your fingertips everything you need to keep you up-to-date on changing climate conditions.

The Advanced Weather Computer is an intelligent system, sounding alarms whenever threatening weather approaches. In addition, the ID-5001 is the only weather instrument known which automatically averages wind speed and direction to FAA/NWS standards and gives true values for wind speed and wind direction.

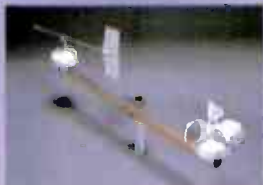

Includes precision wind sensor assembly.

Features:

- High accuracy digital barometer
- Display of indoor and outdoor temperatures
- Push-button display of minimum and maximum readings
- 32-point wind direction resolution
- Display of indoor and outdoor relative humidity
- Digital clock/calendar and much more!

Attractive enough to display in your home, the Advanced Weather Computer is just one of many exciting products in the Heathkit catalog. You'll discover 108 color pages packed full of electronic products in kit and assembled form including TVs, VCRs, computers, test instruments, as well as our new high-tech audio line.

To find out more about the ID-5001 or any of our other fine electronic products, send in the coupon below for your *FREE* Heathkit catalog.

Yes, send me a *FREE* Heathkit Catalog.

Send to: **Heath Company, Dept. 020-714**
Benton Harbor, Michigan 49022

Name _____

Address _____ Apt. _____

City _____

State _____ Zip _____

A subsidiary of Zenith Electronics Corporation

Heath Company

SELECT 5 BOOKS

for only \$3⁹⁵

(values to \$133.70)
and get a Free Gift!



1685P \$11.95

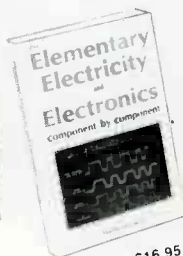

2753P \$16.95



2905 \$19.95



2831 \$22.95



2715 \$16.95

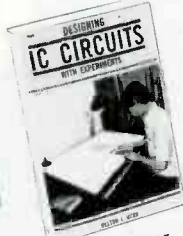

1925P \$16.95



2724 \$24.95



2922P \$15.95



1367P \$17.95



2790 \$18.95



1957P \$14.95



2885 \$16.95

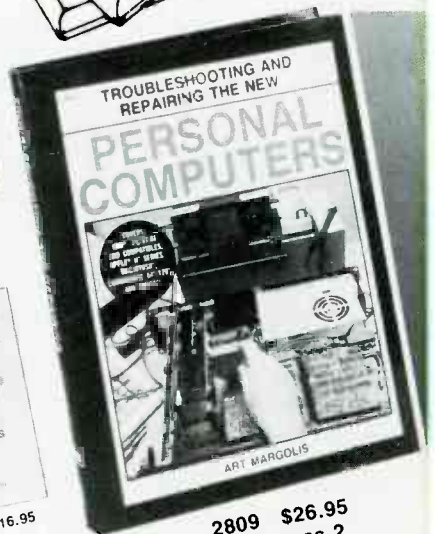

2809 \$26.95
Counts as 2



1498P \$11.95



1498P \$11.95

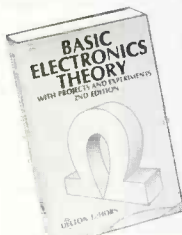

1775P \$18.95



2887 \$16.95



1777P \$18.95



2758 \$24.95



1199P \$18.95

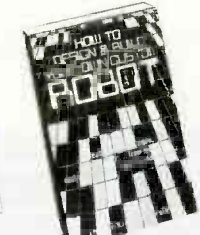

1341P \$14.95



1370P \$18.95



2826P \$14.95

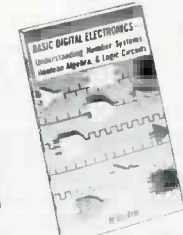

728P \$11.95

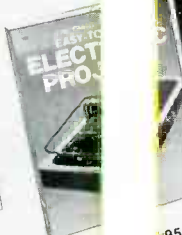

155P \$9.95

Compare this offer with any other book club for Price • Quality • Benefits • Selection!

An Absolute No-Risk Guarantee

33
Fun-and-Easy
Weekend
Electronics Projects
2861 \$14.95

FAB HOBBY ELECTRONICS SERIES
Basic
Electronics
Course
2nd Edition
NORMAN M. CROWHURST
2613 \$23.95

TROUBLESHOOTING AND
REPAIRING
SOLID-STATE TVs
2707 \$26.95
Counts as 2

THE ILLUSTRATED
HOME
ELECTRONICS
FIX-IT BOOK
2883 \$25.95

BEGINNER'S
GUIDE TO
TV REPAIR
1897P \$13.95

LEARNING
ELECTRONICS
Theory and
Experiments
with
Computer-Aided
Instruction
for the
Commodore 64/128
2882 \$24.95

THE COMPLETE BOOK OF
OSCILLOSCOPES
1532P \$14.95

ELECTROSTATIC
LOUDSPEAKER
DESIGN AND
CONSTRUCTION
2832 \$23.95

STATE OF
SOLID STATE
2733 \$14.95

BEGINNER'S GUIDE TO
READING
SCHEMATICS
1536P \$8.95

A BEGINNER'S
GUIDE TO MAKING
ELECTRONIC
GADGETS
1793P \$9.95

CET
COMMUNICATIONS
EXAM BOOK
2910 \$24.95

REMOTE CONTROLLED
ROBOT
FOR UNDER \$300
2617 \$17.95

BUILD YOUR OWN
LASER, PHASER,
YOU CAN GUN,
OTHER WORKING
SPACE AGE
PRODUCTS
1604P \$16.95

101
SOLDERLESS
BREADBOARDING
PROJECTS
2985 \$24.95

30 CUSTOMIZED
MICROPROCESSOR
PROJECTS
2705P \$14.95

FREE when you join!

Here's 15 Easy Electronic Projects From Delton T. Horn

Projects you can build—some unique,
some old favorites—from the author's
vast treasury of electronics know-how.
(a \$7.95 value!)

Delton T. Horn's
All-Time Favorite
Electronic Projects



Membership Benefits • Big Savings. In addition to this introductory offer, you keep saving substantially with members' prices of up to 50% off the publishers' price. • **Bonus Books.** Starting immediately, you will be eligible for our Bonus Book Plan, with savings of up to 80% off publishers' prices. • **Club News Bulletins.** 14 times per year you will receive the Book Club News, describing all the current selections—mains, alternates, extras—plus bonus offers and special sales, with hundreds of titles to choose from. • **Automatic Order.** If you want the Main Selection, do nothing and it will be sent to you automatically. If you prefer another selection, or no book at all, simply indicate your choice on the reply form provided. As a member, you agree to purchase at least 3 books within the next 12 months and may resign at any time thereafter. • **Ironclad No-Risk Guarantee.** If not satisfied with your books, return them within 10 days without obligation! • **Exceptional Quality.** All books are quality publishers' editions especially selected by our Editorial Board.



ELECTRONICS BOOK CLUB

Blue Ridge Summit, PA 17294-0810

Please accept my membership in the Electronics Book Club® and send the 5 volumes listed below, plus my FREE copy of *Delton T. Horn's All-Time Favorite Electronics Projects* (3105P), billing me \$3.95 plus shipping and handling charges. If not satisfied, I may return the books within ten days without obligation and have my membership canceled. I agree to purchase at least 3 books at regular Club prices (plus shipping and handling) during the next 12 months and may resign any time thereafter.

Name _____
Address _____
City _____
State/Zip _____ Phone _____
Signature _____

Valid for new members only. Foreign applicants will receive special ordering instructions. Canada must remit in U.S. currency. This order subject to acceptance by the Electronics Book Club®. Signature of parent or guardian required for all new members under 18 years of age. RE-1188

AUDIO UPDATE

The Audio Engineering Society

I'VE BEEN A MEMBER OF THE AUDIO ENGINEERING Society for some 30 years now, and I credit it—through its monthly journal and meetings—for much of my audio education. Founded in 1948 by a small group of concerned engineers, the new organization was dedicated to advancing the art and science of audio engineering. The Society's success is reflected in both its growth and the international reputation that it has acquired over the past decades. Present world-wide membership includes more than 10,000 engineers, researchers, educators, manufacturers, and students.

Aside from the talks, lectures, and debates scheduled during regular local AES section meetings held in many major cities, scores of papers detailing the latest audio research and developments are presented during the annual conventions. Many of the papers are available in "preprint form," and in the next two columns I'll discuss some of the more interesting ones that came from the October 1987 convention.

First, a background note: In general, AES papers seem to divide into discussions of potential or actual products embodying some new concepts or approaches; discussions of new techniques for improving measurements, recording, or reproduction; and psychoacoustic investigations into audio perceptions. Since the AES prefers to avoid being a commercial-sounding board for any company or in-



FIG. 1

ventor, all papers that appear in the Journal must pass a review board of the author's technical peers. The papers given at the convention—and the preprints of them—are less stringently reviewed by the convention's papers chairpersons. I'll list the AES code number and the formal title of each paper for those who wish to obtain a copy. For information on becoming a member of the AES and/or how to purchase any of its many papers and publications, write to: Audio Engineering Association, 60 East 42nd Street, New York, NY 10165.

2537, G-4

Subwoofer Performance: Accurate Reproduction of

The authors of this paper, whom is with Dolby Laboratories, set out to determine the minimum-performance requirements for home subwoofers as peak sound-pressure level to 120 dB and a crossover no than 100 Hz. An interesting the paper was the frequency analysis of commercial CD's. The authors turned up a dozen (mostly from Telarc) with substantial musical information in the range from 32 to 16 Hz and



LARRY E. KLEIN,
AUDIO ENGINEER

(12 Overture) that went down as low as 12 Hz!

In general, however, the authors found that recordings with audible bass below 30 Hz are relatively rare. When such frequencies are present they are produced by pipe organs, synthesizers, or special effects and environmental noises. Instruments such as a bass guitar, a violin, timpani, or bass drum produce very little output below 40 Hz. At or above that frequency, however, they can make a substantial contribution.

We are all aware of the Fletcher-Ross equal-loudness curves which show that the human ear is significantly less sensitive to low-frequency sounds than it is to mid-frequencies.

It is not generally known, however, that the original curves, which date from 1933, have been substantially revised by later investigators using superior techniques and instrumentation. The most recent studies—which generally agree with one another—indicate that the ear is 6-dB less sensitive at low frequencies than was previously charted.

That means that to be heard as equal in volume to a 4-kHz signal at the hearing threshold of 0 dB, a 20-Hz signal has to be about 85-dB louder! The paper goes on to analyze other performance criteria including the audibility of amplitude, phase deviations, and harmonic distortions, woofer-excursion requirements, room-acoustic effects, and so forth. The paper ends with a plea to loudspeaker manufacturers to improve their low-frequency performance below 40 Hz. It seems that the dozen or so subwoofers tested were all found to be inadequate by the authors' standards.

The paper illustrates beautifully why I find the AES papers so worthwhile. I'm not particularly interested in reproducing frequencies low enough to cause sphincter dilation, but I was fascinated in the wealth of psycho-acoustic and physical data that the authors either developed or researched to make their case. Typical of other AES papers, this paper on subwoofer performance contains a 31-item bibliography.

2490, D-2

The In-store Electronic Distribution of Personalized Music: An Answer to Home Taping

This paper describes a product—or at least a prototype of one—that, if successful, would revolutionize the way that recorded music is sold. The authors are affiliated with the *Personics Corporation* of Menlo Park, CA, and the "abstract" that opens the paper neatly sums up the project:

An electronic music-distribution system has been designed and built to permit the in-store production of very high-fidelity personalized cassettes, to the customer's order. In the store, the system consists of a computer-controlled high-speed optical-disk-based digital-audio archive of up to 15,000 individual selections of music; an order-entry terminal; a high-speed cassette recorder; and a high-resolution label printer.... With this equipment a customer can obtain a high-fidelity tape containing an album-length compilation of the songs he wants in the order that he wants them, after a wait of only about 5 minutes.

The authors state that the impetus for the project came out of a 1985 study (cited in a footnote) that sought to determine the reasons behind home taping. The study found that, contrary to the view held by the Record Industries Association of America (RIAA), the most important reason for home taping was not to save money, but rather to create personal programs by assembling various artists and songs onto a single cassette. The authors are hopeful that in-store album production would appeal to the record companies by essentially eliminating the major reason for home taping, and by simultaneously providing a means of collecting royalties that are now lost.

The bulk of the paper describes the technologies involved. Since the first Personics-system units have already been built, I assume that the technical problems of storing 15,000 separate songs and randomly accessing them rapidly enough to compile a multi-selection high-fidelity recording in

continued on page 81

Official 1934 SHORT WAVE RADIO MANUAL

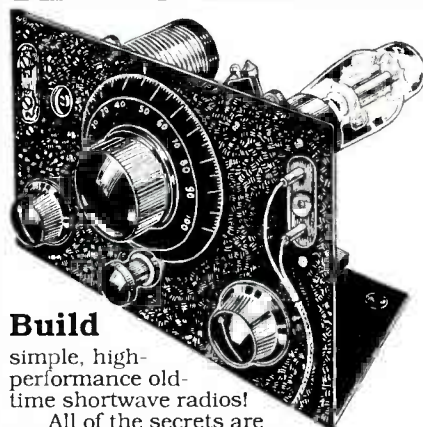

Build

Simple, high-performance old-time shortwave radios!

All of the secrets are here: the circuit diagrams, parts layout, coil specifications, construction details, operation hints, and much more!

This is a compilation of shortwave construction articles from *Short Wave Craft* magazines published in the 20's & 30's. It's wall-to-wall "how-to."

Included are circuit diagrams, photographs, and design secrets of all shortwave receivers being manufactured in 1934 including some of the most famous: SW-3, the SW-5 "Thrill Box", the deForest KR-1, the Hammurand "Comet Pro", and many more.

Also included is a new chapter showing how you can use transistors to replace hard-to-find vacuum tubes. You'll even see the circuit that was lashed together on a table top one night using junk box parts, a hair curler and alligator clips. Attached to an antenna strung across the basement ceiling and a 9 volt battery, signals started popping in like crazy. In a couple of minutes an urgent message from a ship's captain off Seattle over 1500 miles away was heard asking for a navigator to help him through shallow water!

These small regenerative receivers are extremely simple, but do they ever perform! This is a must book for the experimenter, the survivalist who is concerned about basic communication, shortwave listeners, ham radio operators who collect old receivers, and just about anyone interested in old-time radio.

Great book! Fun to read! One of the best old-time radio books to turn up in years. Heavily illustrated! Order a copy today! 8 1/2 x 11 paperback 260 pages only \$15.70 postpaid!

Lindsay Publications

Box 12-WA1, Bradley IL 60915

Send a copy of *Short Wave Radio Manual*. Enclosed is \$15.70. Chk, MC, Visa. Send a free catalog of other books.

Name _____

Address _____

City _____

St _____

Zip _____

HITACHI SCOPES AT DISCOUNT PRICES!

\$100 Price Reduction



V-212
NOW \$379
was \$475
List \$560

Plus 'Free' 9600 Function Generator

All Hitachi scopes include two 50 MHz probes and have a 3 year warranty on parts and labor

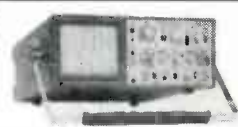

40MHz **V-425** List 995
CRT readout **\$835**



60MHz **V-660** List 1,195
Delayed sweep **\$949**



100MHz **V-1060** List 1,895
Delayed sweep **\$1,195**

Model	Frequency	Probe	Sens.	Features	List	Our Price	Savings
V-223	20MHz	D.T.	2mV	Sens. Delayed Sweep	770	695	75
V-422	40MHz	D.T.	1mV	Sens. DC offset	875	695	180
V-423	40MHz	D.T.	1mV	Sens. Delayed Sweep DC offset	955	795	160
V-1065	100MHz	D.T.	2mV	Sens. Delayed Sweep	1,895	1,575	320
V-1100	100MHz	Q.T.	1mV	Sens. Cursor meas. DVM counter	2,295	1,995	300
V-1150	150MHz	Q.T.	1mV	Sens. Cursor meas. DVM counter	3,100	2,565	535

ELENCO PRODUCTS AT DISCOUNT PRICES!

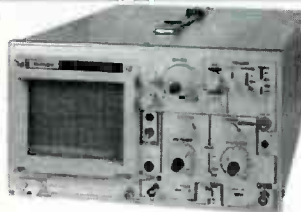

\$349
MO-1251

- 6" CRT
- Built in component tester
- TV Sync
- Much More

20MHz Dual Trace Oscilloscope

Scope Probes

- P-1 65MHz, 1x, 10x **\$19.95**
- P-2 100MHz, 1x, 10x **\$23.95**
- with 5 accessories
- 10 Meg ohms input impedance
- Fits all scopes with BNC connector
- TL-3 BNC to Minigrabber **\$3.49**

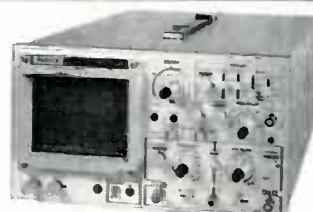

\$499
MO-1251

- High Luminance
- 1mV Sensitivity
- 6KV Acceleration
- 10ns Rise Time
- X-Y Operation
- Delayed Trigger
- Much More

35MHz Dual Trace Oscilloscope

Top quality scopes at a very reasonable price. Contains all desired features. Two 1x, 10x probes, diagrams and manual.



True RMS 4 1/2 Digit Multimeter
\$135 M-7000
0.05% DC Accuracy
1% Resistance with Freq. Counter & Deluxe Case



10MHz Oscilloscope
S-3000 \$239
10MHz DC or AC Triggered Sweep
Calibrated Vert & Hor
Reads Volts & Freq



Decade Blox
9610 or 9620
\$14.95
#9610 Resistor Blox
47 ohm to 1M & 100K pot
#9620 Capacitor Blox
47pf to 10MFD



Low Cost Multimeter
M-1600 \$25
3 1/2 Digit LCD
1% DC Accuracy
10A Scale
Auto zero/polarity



Digital LC Meter
Meas. Coil Inductance
Capacitance
Resistance
(.1 to 1000 ohms)



Breadboard
9436 Shown
9430 1,100 pins \$15
9434 2,170 pins \$25
9436 2,860 pins \$35

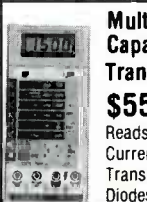

Multimeter with Capacitance and Transistor Tester
\$55 CM-1500A
Reads Volts, Ohms
Current, Capacitors, Transistors and Diodes w/case



Digital Capacitance Meter
CM-1550 \$58.95
9 Ranges
.1pf-20,000ufd
.5% basic accuracy
Zero control w/case



Analog Multimeter
M-1100 \$19.95
19 ranges
High Accuracy
10A reading
Mirrored scale
Kit 17.50



Digital Multimeter
Ac \$36.95
Ac \$42.95
Ac \$39.95



Function Generator Blox
#9600 \$24.95
Provides sine, tri, squ wave
From 1Hz to 1MHz
AM or FM capability

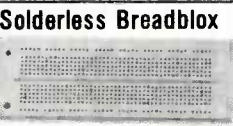

Solderless Breadbox
550 tie pts including 2 power bus lines
#9550 \$7.50



IC Test Clips
16 pin \$5.95
20 pin \$8.25
24 pin \$10.75
28 pin \$11.75
40 pin \$18.50
All are gold plated to assure trouble free contact



Temperature Probe
M-110CF \$29.95
Semiconductor type
Range -58F-302F
Fits most digital multimeters



50MHz Logic Pulser
LP-700 \$23



Digital 3 Amp Power Supply
XP-750 \$175
0-40V @ 1.5A
0-2V @ 3A
XP-650 with Analog Meters \$129.50

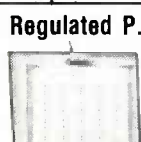

Regulated P.S. Breadboard
\$99.95 XK-400
• Fully regulated
• Short circuit protection
• 3550 test points
• 3 power supplies
• 5V @ 2A, 12V @ .3A, -12V @ .3A



GF-8016 Function Generator with Freq. Meter
\$299
• Sine, Square, Pulse, Ramp
• Frequency 10MHz



Digital Triple Power Supply
XP-765 \$239
0-20V @ 1A
0-20V @ 1A
5V @ 5A
Fully Regulated, Short Circuit Protected with 2 Limit Cont. 3 Separate Supplies
XP-660 with Analog Meters \$169.50



Quad Power Supply
XP-580 \$59.95
2-20V @ 2A
12V @ 1A
5V @ 3A
-5V @ .4A
Fully regulated and short circuit protected
XP-575 without meters \$44.95



Four-Function Frequency Counter
\$259
Frequency, Period, Totalize, Self Check w/ Stabilized Crystal Oven Oscillator, 8 Digit Display
\$179

WE WILL NOT BE UNDERSOLD!



C & S SALES INC.
1245 Rosewood, Deerfield, IL 60015
Add 5% for Postage (\$10 Max) IL Res., 7% Tax

(800) 292-7711 15 Day Money Back
(312) 541-0710 2 Year Warranty
ASK FOR FREE CATALOG

CIRCLE 109 ON FREE INFORMATION CARD

THE FACTS ON FAX

HERB FRIEDMAN,
COMMUNICATIONS EDITOR



Fax is an easy-to-use, low-cost way to send copies of text, graphics, and pictures by telephone.

A MODERN FACSIMILE MACHINE, WHICH IS more commonly known simply as fax, is a device that scans a document and converts it to digital data that can be sent over the national and international dial-up telephone systems. A receiving fax creates a facsimile of the original document by restoring the data to its original form.

Because there is a worldwide standard for facsimile signals, fax machines can send documents anywhere in the world—except to countries which prohibit non-voice or encoded signals on their telephone network. Because modern fax is entirely digital, a document can be sent in less time than it would take to be read or described by voice; hence, the telephone charges per document are minimal—particularly so for long distance and international calls.

A mass market

Many marketing experts involved with office and household electronic products believe that the fax machine will shortly become another mass-marketed electronic gadget; one that might turn out to be as popular as VCR's, video cameras, and personal computers.

In fact, the future of fax as the next electronic blockbuster looks so good that the major manufacturers are al-

ready gearing up for blitz advertising aimed at the home-business market. Pick up almost any newspaper and you'll find that the fax machine is the featured equipment in many advertisements from stores that sell consumer photo and electronic equipment. It is also featured in the ads from computer dealers, and by the stores that sell telephones and office equipment. And if you drive down the business district of any moderately sized city or town, you'll now find stores that specialize only in fax machines.

There are even fax adapters for IBM-compatible personal computers. Simply plug in a fax adapter and your computer will function as an online fax even while the computer is doing some other job, like word-processing, or filing, or whatever else personal computers do. (A future issue of *Computer Digest* will present a hands-on review of such a device.)

Old movies

What might temporarily limit the growth of fax is the fact that many non-business consumers have little or no idea about what fax is or can do. If they know anything at all about fax, it's probably from TV re-runs of old 1930's B-movies, where a group of newspapermen watch a facsimile ma-

chine create the face of Public Enemy Number 1 on what appears to be a spinning drum. Or the machine might be spinning out a picture that will prove the innocence of someone minutes away from execution in the Big House (state prison).

Although the facsimile machine was a common productivity tool for newspapers, news magazines, and major business offices, it was a very expensive and difficult-to-maintain mechanical clunker; so other than in the movies, until *digital electronics* became a household phrase, the average consumer had little acquaintance with a facsimile machine.

But because of the simplicity of operation, unusually good reproduction and reliability, and plunging prices made possible by digital technology, fax is expected to be used by almost all businesses operating from a home. It is even anticipated that fax will prove to be a popular household appliance. For example, suppose you're working at home and find that you need some papers that you left at the main office. Instead of waiting for the mail, or paying for expensive courier service, you simply ask the office to fax you the papers. In less time than it takes to think about it, your fax machine starts spitting out copies of the documents.

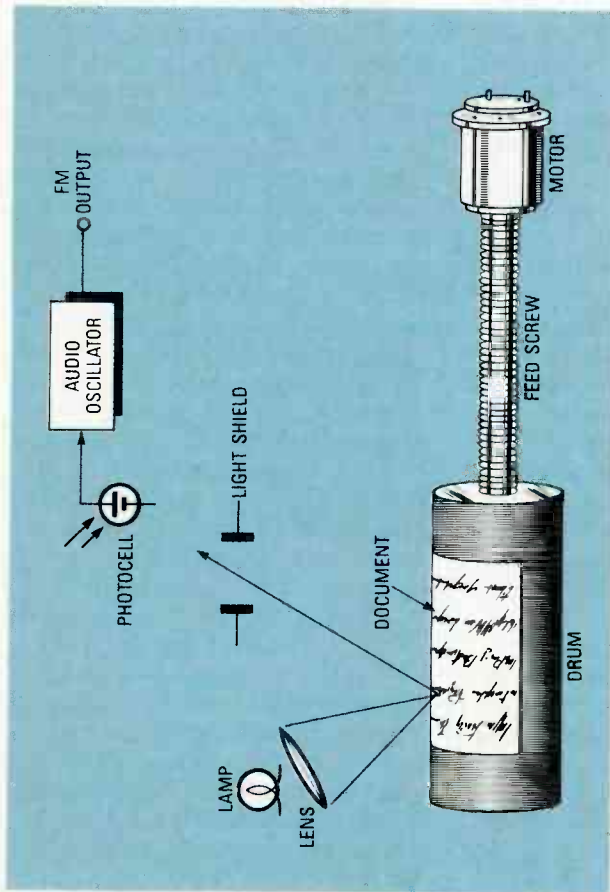

FIG. 1—ON EARLY FAX MACHINES the document was mounted on a spinning drum that was tracked by an electro-mechanical assembly.

Or assume that you have a billing dispute with the local bank. They claim you didn't pay; you claim you did. Instead of getting involved with the bank in several months of correspondence to prove that you paid, you simply feed the canceled check into your fax machine, and in less than 30 seconds a copy appears on the bank's fax machine. That should resolve the dispute quickly; you and the bank won't have to become pen pals.

Or maybe you just want a quote on what it would cost to purchase a new refrigerator. Instead of waiting on the phone listening to "elevator music" until someone can help you; then explaining what you want; and then

determine how much light is reflected from the document. A photo-electric

sensor positioned in the reflection path senses the amount of reflected light and converts the reflection to a bi-level or gray-scale electrical signal, which is then used to control an audio oscillator, a microprocessor, or whatever is used to create the transmitted signal's modulation.

Although manufacturers eventually intend to equip high-end fax machines with laser printers, the common fax machines print received documents or photographs on thermal (heat sensitive) or electrostatic paper. The image is formed by a heat or an electric burning stylus that tracks over the paper. The heat stylus actually burns the image into thermal paper, while an electric current passing from the stylus through electrostatic paper changes the color of electrostatic paper at the "burn." In both types of printing, we say the image is "burned in." Early fax machines also used a light-sensitive (photographic) system, which meant wet-process developing, and some machines used a wet paper to provide conduction for an electric "burn." Obviously, wet-process printing hasn't been used for many, many years.

Figure 1 shows how early fax machines, such as the Western Union *Telefax*, work. The document to be transmitted (fax'd) is mounted on a metal drum that is attached by a threaded feed-screw to a motor. The motor both spins the drum and feeds the drum down the screw. Positioned above the drum is the optical system consisting of a lamp, its focusing lens, and a photocell that is connected to an audio oscillator.

As the drum revolves, the document is scanned by the beam of light. There is a separation of scanning lines because the drum also moves down the feed screw as it spins. (The scan is a helix at the surface of the drum.) The photocell senses the changing light intensity caused by the characters on the document and produces a varying DC voltage corresponding to the light intensity. The voltage, in turn, determines the frequency of a voltage-controlled oscillator.

Since the frequency of the audio oscillator is determined by the photocell-generated voltage, the system is said to use FM—short for frequency modulation.

The receiver is the same unit as

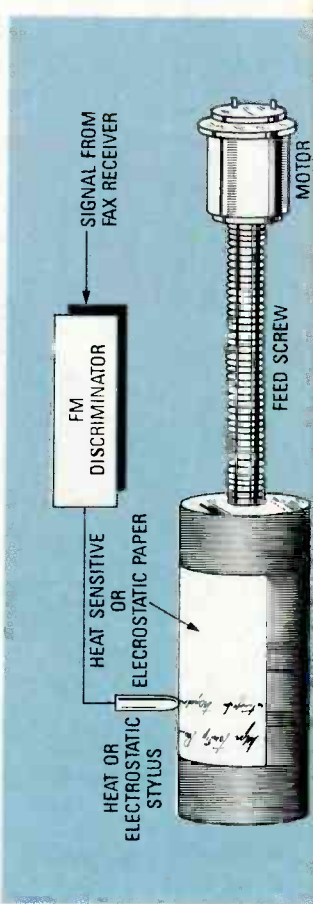

FIG. 2—WHEN RECEIVING, THE IMAGE was literally burned into a blank sheet of paper that was mounted on the drum.

simply write what you want on a sheet of paper and fax it by telephone line to

speed is determined by the powerline's frequency). When DC motors were used, synchronization required a lot of tweaking. In a modern all-electronic fax machine, synchronization is achieved via an electronic signal.

Drum systems were in use for many years. As with everything else involved in international communications, the drum system was standardized by the CCITT. (CCITT is an acronym for the International Telegraph and Telephone Consultative Committee, the organization that sets the standards used for all international communications.) The CCITT standard, which is known as Group 1, G1, or G1, uses FM modulation and takes six minutes to transmit a CCITT "standard" test page. (Henceforth, whenever we refer to the transmittal

etc. We'll get to those features later.

Between the electro-mechanical and the digital eras was a period when fax used electronically derived AM modulation—the scanning and printing was no longer done on a spinning drum. The document was scanned on a flatbed, and the printing paper fed from a roll. The all-electronic system could provide automatic dial-up and answer, originate and answer identification, and unattended operation. The system's parameters are also set by the CCITT and are known as Group 2, G2, or G11. A Group-2 machine can send a standard page in three to four minutes—about half the time than it would take using a Group-1 machine.

Digital

Group-2 machines were just a way-

speed of a standard page we mean the CCITT's standard test page.)

The digital breakthrough

Six minutes per page transmittal time is not spectacular; it can result in substantial telephone charges, particularly on international circuits. Because of the time and cost limitations, fax was essentially limited to businesses that absolutely required real-time or rapid document delivery (as compared to mailing the document).

But the digital era brought with it electronic scanning, which meant that the entire mechanical paper-handling system could be eliminated. It also brought with it the modern computerized communication services such as storage, store and forward, polling, broadcasting, password security, automatic modem fallback,

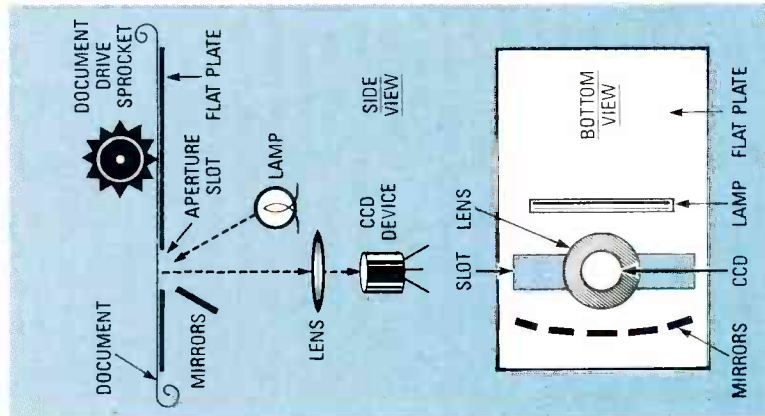

FIG. 3—THE MODERN FAX MACHINE uses a photo-optical electronic scanner, and the document is usually moved past an aperture slot that's cut into a flat plate.

used for transmitting but, as shown in Fig. 2, when the machine functions as a receiver an image-creating stylus swings into position to replace the optical system (or both are combined in a single housing). A demodulator in the receiver converts the received audio tones into electrical signals that are used by the stylus to burn a reproduction of the source document into a blank sheet of paper. As a general rule, synchronization between the drums of the transmitting and receiving machines was attained by using synchronous AC motors (whose

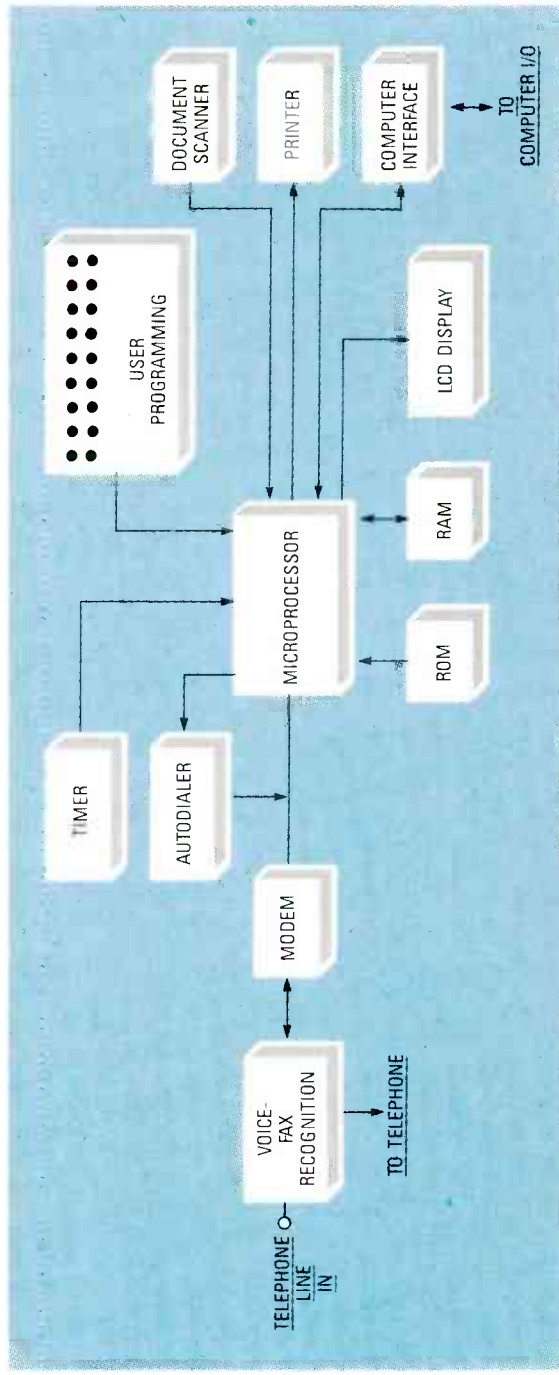

FIG. 4—THE FUNCTIONAL BLOCK DIAGRAM of a generic upscale fax machine. The ROM contains the operating system, handshake codes, and answerback control. The RAM can contain multiple incoming and outgoing documents, as well as a telephone directory and user-programmed instructions. The LCD shows what's programmed and what's happening, and prompts the user.

15 seconds.) The digital-fax CCITT standards are Group 3 (G3, GIII) and Group 4 (G4, GIV). The Group-4 method does not work on the dial-up telephone system, because it is intended for the 4-wire ISDN network—so we will restrict our discussion to the Group-3 machines. However, keep in mind that modern fax machines are often downward compatible: Group-4 machines will usually also function as Group-3 machines, just as many of the Group-3 machines are compatible with Group-2 and, sometimes, Group-1 machines.

Figure 3 is a generic representation of the most common scanning system used by Group-3 machines. As you can see from the side view, the document is pushed (or pulled) across a scanning slot that is cut into a flat plate.

As shown in Fig. 3, the portion of the document at the slot is evenly illuminated by a lamp that extends across the width of the slot. A series of mirrors compacts the image reflected from the document into the acceptance angle of a lens, which, in turn, focuses the image on the face of a CCD device. Electronic scanning of the CCD provides a bi-level (high-low) signal for the electronic system. The document's drive sprocket operates with a step-and-stop motion that is controlled from the same circuits that process the CCD image. The drive sprocket advances the document at the end of each CCD-image line. If the next line is blank, and then the next the outgoing digital signal is

simply advances the printing paper until characters are available. The compression of both white and data is

a primary reason why a Group-3 machine can process a standard page in as little as 18 seconds. (Including handshaking, a total of 45 seconds.)

Depending on the degree of desired bi-level or gray-scale resolution (from coarse to fine), and the modem speed (which we'll get to shortly), Group-3 standard-page transmission-time can vary upward from 18 seconds to nominally three minutes.

Fixed position

A recent variation—that is specifically called *flatbed scanning*, moves the slot under the document. (*Flatbed scanning*, which formerly meant a flat-plate substitute for the spinning drum of Group-1 machines, now usually means a Group-3, a Group-4, or a computer scanner, on which the document remains in a fixed position while being scanned.) The mirrors, the lens, the CCD, and the lamp are an integrated mechanical assembly that moves under the document. The bed itself is glass; the slot is actually an "optical slot"—the viewing area seen and reflected by the mirrors.

Contact scanning

As you might imagine, the mirror/lens/CCD/lamp assembly is somewhat complex and moderately expensive. However, a much lower-cost all-electronic *contact scanning* system has been developed. While it doesn't have all the capabilities of the mirror/lens/CCD system, at present it is perfectly suitable for use in the rock-bottom-priced fax machines. Eventually, just because of its simplicity,

scanners will probably become the commonly used scanning device.

The contact-scanning sensor is a

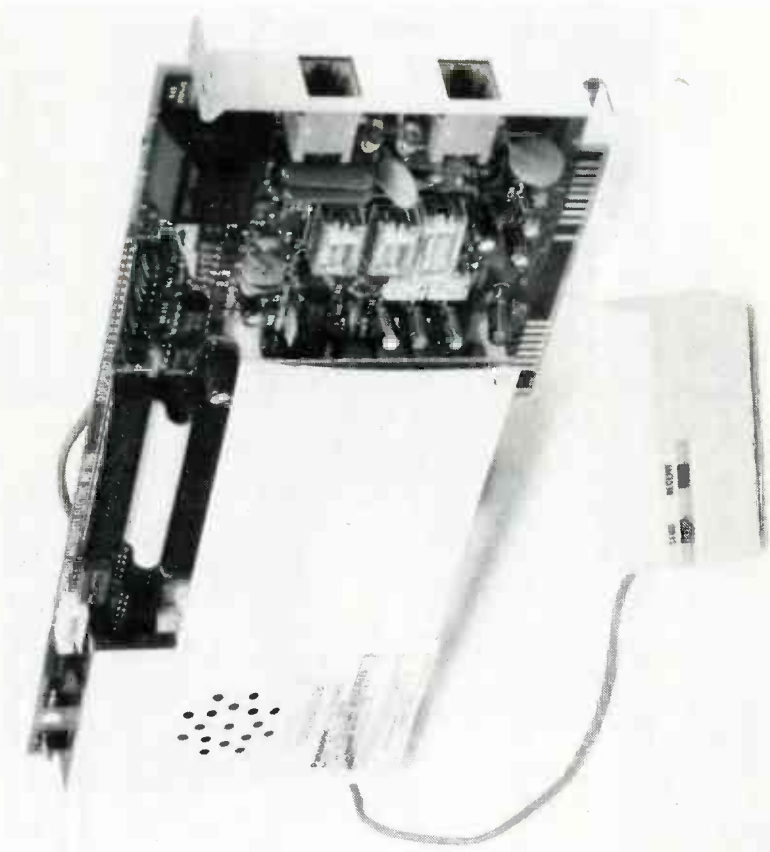

FIG. 5—THE PANASONIC FAX ADAPTER has connections for both the telephone line and the local phone. An on-board monitor speaker for the modem allows the user to monitor the telephone line only until the fax communications circuit is established, or throughout the fax transmission.

long, thin, electro-optical sensor tube that extends across the slot. Although not the same as a CCD, the tube functions more or less in the same way. The reflected light forms a pattern on the sensor across the width of the slot. Electronic scanning of the device's target area produces the same kind of bi-level and gray-scale digital output as a CCD. As with the CCD system,

fixed slot, or it can be used in a flatbed scanner, with the tube and a lamp moving under the document. Mirrors

and a lens aren't needed because the tube's angle of view at the document is very narrow—again, an optical slot.

Computerized

As shown in Fig. 4, a generic block diagram of a high-performance Group-3 fax, the electronic hardware

automatic voice-tax recognition, a telephone autodialer, computer interfacing, and some kind of answer/

originate modem. In the less expensive Group-3 fax machines, the modem has a fixed transmission rate of 2400 bps. More expensive models have a 9600-bps fall-back modem. Since the modem probably has the greatest affect on the transmission time of a standard page, let's cover the modem first.

It's easy enough to understand a fixed-rate 2400-bps modem: it simply does its thing at 2400 bps. A fall-back modem, however, tries to transmit at a higher speed, usually 9600 bps. (Yes, a good dial-up telephone circuit can handle 9600 bps.) The originating modem "tests" the answerback signal from the answering fax machine. If the answering machine senses an incoming 9600 bps, and if it has the capability, it will electrically handshake at 9600 bps. If the answering machine is equipped only for 2400 bps, its answerback at 2400 bps is sensed by the originating fax machine, and the originating machine shifts to 2400 bps. Otherwise, both machines start out at 9600 bps (or they start at the top rate of the slower machine.)

As with any other protocol data exchange, the answer modem constantly tests for transmission errors. If it senses too many errors on the communications path, it sends an electrical request to the originating modem to fall back to 7200 bps. If there are too many errors at 7200 bps the modem will automatically fall back to 4800 bps, and if there are still too many errors the machine falls back to 2400 bps. As you can imagine, each fallback increases the transmission time of the document. (From time to time, the originate modem will try to get back to 9600 bps. The

system tries to maintain the highest possible transmitting speed.)

Normally, a separate telephone line must be available for fax reception, or the machine must be manually or automatically switched to fax for transmitting when the machine also has a built-in conventional telephone. However, as shown in Fig. 4, some upscale fax machines feature automatic voice-fax recognition, which allows the machine and a telephone to share a common line for incoming calls. When the machine answers a call it monitors for an electrical handshake from an originating fax. If it senses the handshake, the machine connects its own internal modem to the telephone line. If there is no handshake, the machine connects its own telephone, or a conventional external telephone. Although Fig. 4 shows the voice-fax recognition as a separate unit, that's done only for clarity; the actual circuit is usually part of the fax machine's modem.

The RAM can store the scanned image itself, and it can also be user-programmed with: 10-100+ telephone numbers for the telephone autodialer; the time a fax will be transmitted from RAM; a broadcast schedule, and incoming and outgoing password protection.

Broadcasting, also known as group distribution, means that the machine will automatically send the document from RAM to two or more machines at a specific date and time. Password protection works for incoming and outgoing traffic. Most high-performance machines permit *polling*, which means that a remote machine can dial in and request that a document stored in RAM be transmitted. Since many documents can be stored

in RAM for selective polling (or timed-transmission), password protection allows polling machines to request only the documents that they are authorized to receive. On the flip side of the coin, high-performance machines don't necessarily print every incoming document; they can be stored in RAM for selective printing at a later time. A password allows access to the document only by the person to whom the document is specifically addressed.

Keep in mind that because Group 3 machines are digital, the document can contain text, line art, computer-generated bit-level or gray-scaled graphics; or the "document" can originate in a computer. Some of the more expensive machines provide a computer-to-fax interface that allows disk files to be fed directly into the fax machine. As far as the machine is concerned, the computer data is a conventional document. When receiving, the fax machine can either print the document or store the incoming data as a computer disk file.

Although the majority of the fax machines have thermal or electrostatic printers, some high-end models have laser printers, or allow connection to a laser printer so that the document can be used directly for camera-ready page makeup.

Computerized fax

Basically, anything in the way of communications that's possible with a computer is possible with a full-blown fax, which leads us to, you guessed it, fax adapters for IBM-compatible computers.

Figure 5 shows a fax adapter for a PC/XT computer, Panasonic's *FX-BM/89*. It simply plugs into a slot and

has the usual modem connections for the telephone line and the telephone instrument.

Usually, the software for high-performance computer fax adapters such as the *FX-BM/89* reside in memory and work in the background. In that way, the fax function is automatically available even during the time that the computer is being used for other tasks. The adapter essentially provides all the functions of a conventional fax except that the signal inputs to and outputs from disk: You store text, graphics, and scanner output as a disk file.

The fax adapter transmits any fax-formatted disk file as a conventional fax signal. To incoming fax, the adapter appears as a conventional upscale fax machine, except that it can store incoming data on disk for future use or for future printing.

Again as provided by the software, the fax adapter can "store" multi-address pages, will store-and-forward on a selective or broadcast basis, and will respond to polling.

As with conventional Group-3 fax machines, a fax adapter's features and functions vary from model to model. Actually, the functions and features of a fax adapter are determined more by the software than the hardware. The lower-cost adapters emulate the features of the lower-cost fax machines; the more expensive adapters emulate upscale fax machines.

Whether you're interested in a stand-alone fax machine or a fax adapter for your computer, keep in mind that just about every conceivable communications feature and convenience is available; but remember that every upgrade usually means additional cost. **R-E**

IT WAS ALMOST FIFTY YEARS AGO THAT *Radio & Television* magazine—a sister publication of *Radio Craft*, which eventually became **Radio-Electronics**—published two articles that I wrote on the subject of radio facsimile. In those days, radio facsimile was new and highly experimental. I was still in high school when I became fascinated by the experimental facsimile transmissions that were broadcast by UHF station W8XE in Cleveland, Ohio. Not having access to commercial equipment, I began to experiment with different ways to print out the material. My experiments resulted in two machines, which were the subject of my articles in the November 1940 and January 1941 issues of *Radio & Television* magazine.

About the time I finished my own machines, I came across two surplus Crosley Model 119 READO facsimile kits, which had been manufactured as part of an evaluation program designed to test the feasibility of broadcasting newspapers by radio, so that readers could get the news instantly, not hours or a day after it took place. Among other things, the imminence of World War II terminated the experimental facsimile broadcasts in 1941, so I purchased the READO kits in the hope of continuing my experiments. I intended to use one of the units as a scanner, the other as a printer. My efforts proved partially successful, but an inadequate optical system resulted in poor resolution and a somewhat noisy picture quality.

About that time I joined the U.S. Army and was assigned to a radio station. I had to suspend further experimentation with facsimile

FACSIMILE:



1940 — 1988

An early experimenter with radio facsimile brings an old home-brew up to date with solid-state circuits.

CARL A. HELBER

Time marched on, but for some reason I held on to the two facsimile sets. Finally, after almost 50 years, I found the time to continue my experiments with facsimile. This article describes the design and construction of the original scanner, printer and

assembly—which were not even envisioned nearly fifty years ago—that I used to get the units working.

id-state circuits, I had many recollections of the way things used to be done, or as someone said, “as it used to was.” For example, because the amplifiers had very high input impedances the construction of any electronic project almost always required extreme care in the placement of the wires that connected the vacuum-tube filaments (heaters); at the very least, the wires had to be tightly twisted to reduce the ever-present hum pickup. In fact, particular care had to be taken with all wiring because the sheer physical size of the components used for vacuum-tube circuits usually resulted in long leads, which made the circuits particularly susceptible to noise pickup.

Then there were the problems of physical size and weight. There were no transistors or IC op-amps a half century ago. Typical of vacuum-tube technology, yesteryear’s circuits required 90 to several hundred volts instead of the 15 volts or less that is common in many solid-state circuit designs, so the power supplies were usually humongous.

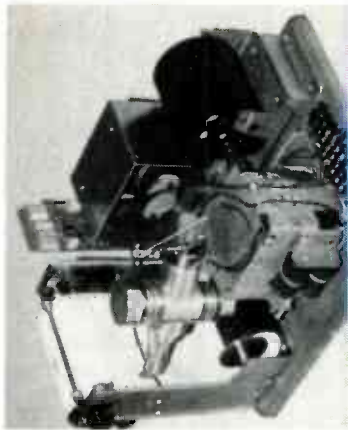

FIG. 1—A 50-YEAR OLD scanner. The document was prepared from a roll of sprocket-fed paper.

Big and heavy
Everything about the old machines was big—actually huge. Figure 1 shows just the mechanical assembly for my old scanner; Fig. 2 shows the printer. The electronics for each was

assembled in a concrete enclosure (which was an assembly).
As I proceeded with my upgrading of the old machines using modern sol-

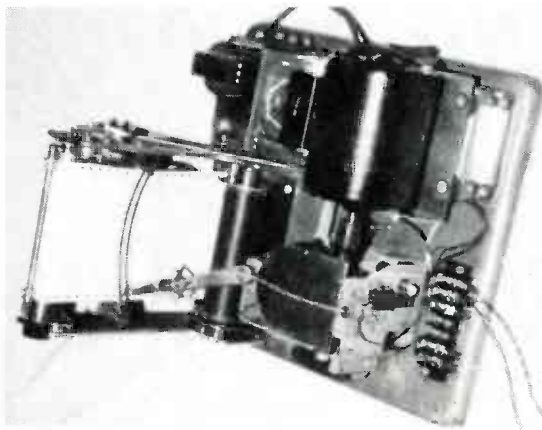

FIG. 2—THE PRINTER used electro-sensitive sprocket-fed paper. The image was literally burned into the paper by a high-voltage stylus.

The Finch Facsimile System

While my upgrading of the old equipment is based on the configuration of the Finch facsimile system, there is no reason why the same optical and electronic design can't be applied to drum-type scanners.

In the Finch facsimile system the document to be transmitted is spring-loaded against a curved platen. An optical assembly sweeping back and forth about the radius of curvature of the platen projects a tiny, bright spot of light onto the document. A phototube mounted on the optical assembly picks up the light reflected off the document. Since the intensity of the reflection varies directly with the density of the point being illuminated, a relatively large phototube current is produced by reflection from a white area, while the reflection from black generates a small phototube current.

Unfortunately, "relatively large" is a nebulous term; under the best of conditions the currents are very small—a few tenths of a microampere.

Typically, the tiny currents are converted to voltage and applied as modulation to an AC carrier. The carrier signal is then further amplified to a level suitable for modulating a radio transmitter. In the Finch system, the carrier frequency is 2000 Hz for document transmission and 400 Hz for the synchronization signal that keeps the scanner and printer synchronized.

The Finch facsimile printer uses a stylus sweeping back and forth across electro-sensitive paper that is sup-

ported by a curved platen similar to the one used in the scanner. (I believe that the paper used a thin coating of titanium dioxide over a carbonized backing.) Signals received over the radio link from the scanner are amplified to several hundred volts in a conventional tube-type power amplifier and then applied to the stylus. The high voltage at the point of the stylus burns off the light-colored coating to a degree dependent on the magnitude of the voltage. As more of the coating burns away, more of the black backing shows through. (Too much voltage would cause the backing to burn through.)

Synchronizing pulses sent by the scanner energize an escapement lever in the printer at the beginning of each scan line. The printer is designed to run slightly faster than the scanner so that the stylus arm, which is driven thru a slip-clutch mechanism, will be waiting for the sync pulse at the start of each scan. This kind of mechanical synchronization was necessary, even though synchronous motors were in use in 1941, because most major power companies were not synchronized with each other as well as they are today. At present, by using synchronous motors, it is usually only necessary to get the printer started at

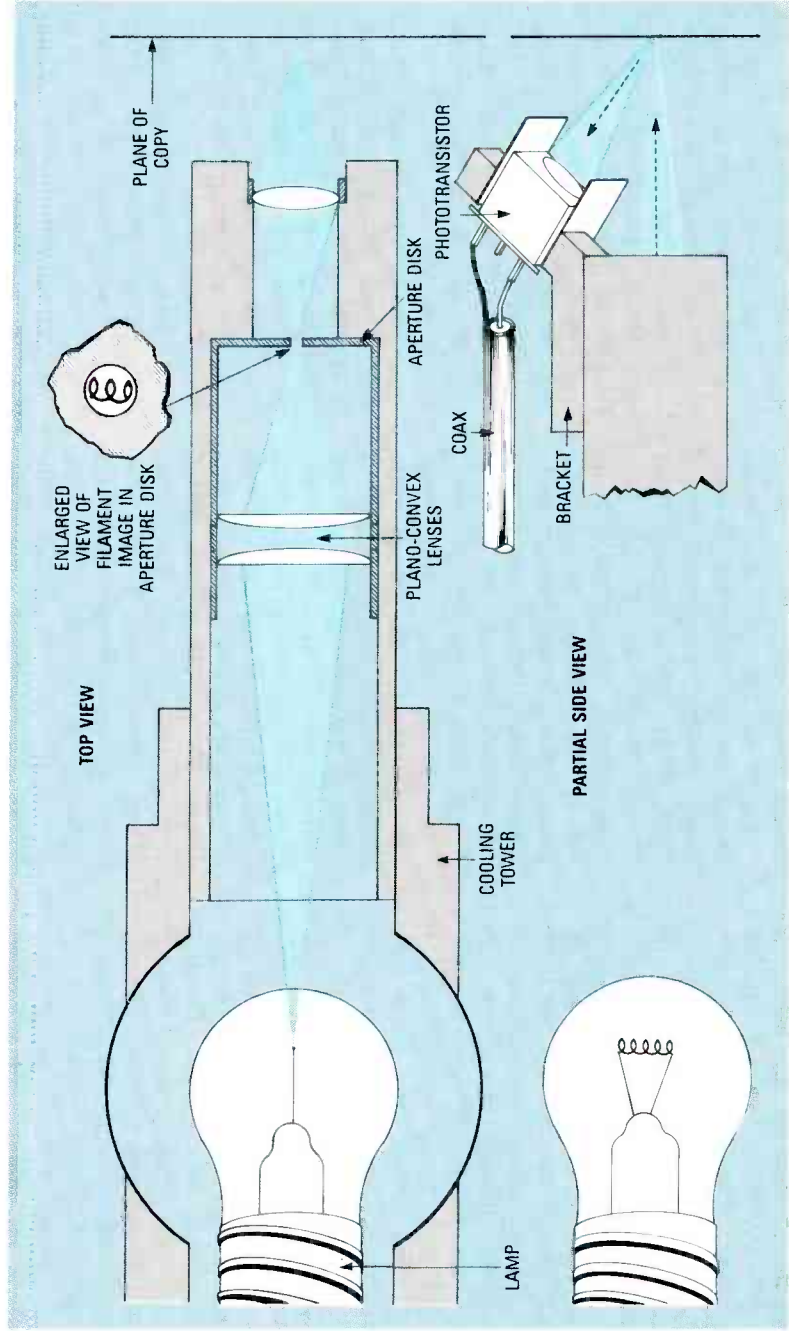

FIG. 3—THE NEW SCANNER OPTICAL SYSTEM. A major improvement is the substitution of a phototransistor for a phototube as the reflected-light sensor.

the right point at the beginning of the transmission; after that the escape-level lever is left energized until the transmission is completed.

The scanner

As I mentioned earlier, at best the optical system used in the original design resulted in a phototube current of a few tenths of a microampere. To achieve even that minuscule level, a type 923 gas-phototube operating at about 90 volts was required. While a load impedance of several megohms could result in a signal voltage in the range of 1-2 volts, the hum problem at such a high load impedance was formidable. On top of the problem of low output voltage, the signal had to modulate a carrier so that it could be amplified still more by stable amplifiers. When I interrupted my experiments in 1941, I had not yet resolved to my satisfaction the problems of low output voltage and susceptibility to hum.

But technological advances in the last twenty years have been so great that all of the early problems essentially disappeared when I substituted solid-state circuits (transistors and IC's) for the original vacuum tubes. For example, DC amplification was quite difficult to accomplish with a high degree of stability in the early days. Today, feedback techniques for IC op-amps make transfer characteristic shaping and gain adjustment relatively easy.

New optics

Figure 3 shows my new optical sys-

lights—provides the light source. The lamp's filament is a 20-mil diameter tungsten coil 0.3-inch long that oper-

ates at 12 volts at slightly less than 1 ampere. A scanning spot 0.01-inch high by 0.0067-inch wide is obtained by using a demagnifying lens system to image the filament on a 10-mil diameter aperture. The resulting spot width is determined by the filament's width, while the spot's height is determined by the aperture's diameter. A 10-mil horizontal slit could have been used and would have made the demagnifier alignment non-critical, but it is much easier to fabricate a small, round aperture. A 1:1 projection system using a short focal length lens images the illuminated aperture on the document being scanned.

The aperture is created in a 0.5-inch diameter disk of 5-mil brass shim stock having a deep dimple in the center. (A sharp pointed pin or needle is used to form the dimple.) The disk is then placed dimple point down on a sheet of 400-grade silicon carbide paper and rubbed until enough brass is removed to leave a 10-mil hole.

As shown in Fig. 3, a phototransistor is mounted at the end of the lens tube. Because the case of the phototransistor is connected internally to the collector, which in turn is connected to +12 volts, the phototransistor is insulated from its metallic mounting by a layer of insulating tape. A length of RG-188 coax cable carries the phototransistor's signal to its amplifier.

Light from the 12-volt lamp must be prevented from directly illuminating the document being scanned, but it is essential that the lamp be cooled

stream into cylindrical baffles positioned both above and below the lamp. The baffles direct the air around

the lamp while preventing uncontrolled light radiation.

Figure 4 is the circuit used in my current scanner. Transistor Q1 is the phototransistor located on the optical head. White areas of the copy being scanned produce a current of 5-10 microamperes, while black areas result in less than one 1-2 microamperes. Potentiometer R1 compensates for any stable offset current that might be caused by ambient room illumination reaching the phototransistor.

Op-amp IC1-a is a current-to-voltage converter with provision for changing signal gain (R3), and for clamping the white level if necessary. Potentiometer R5 is used to set the black clamping level to prevent overdriving the printer when adjustments are made to enhance the resolution of fine detail in the scanned material. For example, a narrow line whose width approaches the width of the scanning spot will generate a smaller signal than a broad line of the same gray level. The print density of the

narrow line (fine detail) can be improved by adjusting R5.

The troublesome, somewhat touchy vacuum-tube modulator used in the early equipment is replaced by a simple transistor clamp (Q2) that also serves as a clamp for removing the scanned signal during the return stroke of the scanner head. A 1455 timer (IC2) generates the 2-10-kHz carrier; R11 sets the carrier's frequency. Switch S1, the *return scan disable*, is actuated by the scanning mechanism.

Potentiometer R6 adjusts the chopped signal amplitude and R9 adjusts the DC offset as required by the receiving circuitry. R9 would not be used in a radio transmission system; instead, a bandpass filter would be used to remove the DC and the low-frequency components while leaving, in effect, a balanced-modulated carrier to be applied to the transmitter.

The adjustment of the scanner's electronics starts by manually pointing the scanning head at a white area

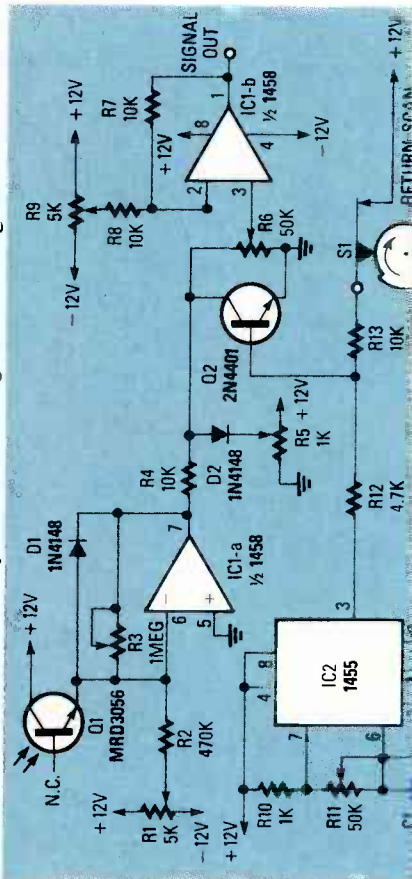

FIG. 4—THE NEW SCANNER ELECTRONICS is all solid-state. The carrier is generated by timer IC2.

of the document being sent. R1 is adjusted so that the voltage at pin 7 of IC1-a is zero or slightly negative. Next, the head is pointed at a center of the finest black line to be transmitted, which should cause the voltage at pin 7 to go several volts positive. (R3 is used to adjust the level to 3-4 volts.) R5 is adjusted so that with the base of Q2 grounded, the voltage at Q2's collector just begins to clamp. If R3 has been changed substantially, it might be necessary to repeat the previous procedure. Finally, R6 and R9 are set to provide the signal needed by the printer. In my current equipment, it is a 1.5-2-volt peak AC signal (full white to full black) sitting on top of a 1-volt DC offset.

The printer

Figure 5 is the schematic of my most recent printer circuit. From the outset, it was obvious that the stylus

transformer used in the original equipment would not be suitable for use with easily available transistors. The original transformer worked with tubes like the 6L6, which required a plate voltage of 250-300 volts. Common power transistors usually work at well under 100 volts, and usually at only 15-20 volts at the 5-10-watt power level required to mark the electrosensitive paper.

Calculations for stylus-driver transformer T1 indicated a turns ratio of 29:1 on a 3/4-inch square core. It turns out that a Triad F-16X filament transformer has the same size core and a turns ratio of 36.5:1 between one-half the secondary and the 117-volt primary. A power transistor operating at approximately 20 volts should be able to provide a stylus voltage about the same as that provided by a 6L6 operating at 250 volts. That indeed turned out to be the case. In fact, a 15-volt supply turned out to be more than adequate.

Power transistor Q2 is normally cut off until the signal reaches about +1 volt. From 1 volt to about 2.5 volts T1's secondary voltage rises from a level that produces a barely discernible mark to a level where the backing paper begins to burn through. (Average collector current rises to about 500 mA.)

Capacitor C1 slows the amplifier's rise time to suppress any tendency towards oscillation caused by stray-capacity feedback from Q1's output to its input. Switch S1 is a return-stroke signal-disable switch like the one used in the scanner.

It really works

For almost 50 years I managed to hang on to several 100-foot rolls of the

PAGES 12-15-41/RB
1. Introduction
(1) Forty seven years ago, 1940, I was a high school and began to experiment with articles I wrote presented construction information about two machines which resulted from this work.

FIG. 6—50-YEAR-OLD electrosensitive paper was used to make this facsimile of the original draft of this article.



FIG. 7—EVEN PHOTOGRAPHS can still be reproduced using the old equipment and paper.

special sprocketed facsimile paper used by my mechanisms. Surprisingly, after nearly a half-century there appears to be no deterioration in the paper's recording quality. Two samples of documents sent from the scanner to the printer over a direct wire link show that my up-to-date cir-

cuits work very well with the ancient mechanisms. Figure 6 is a facsimile print of the original draft of this article; Fig. 7 is a facsimile print from a photograph of a well-know politician.

In fact, as you can see from Fig. 6, the reproduction of the individual characters by my refurbished printer compares favorably with the print quality from some of the new machines.

Conclusions

This project has been fun, to say the least. It was interesting to recall the many difficult circuit problems I encountered when building facsimile equipment back in the 1940's. It was even more interesting and satisfying to see the enormous progress made possible by modern electronic components.

But as good as my results are, much experimentation with clamping levels, offsets, and gain remains to be done to improve the gray-scale performance of the system. Unfortunately, the time will come when my supply of electrosensitive paper is exhausted. In view of that eventuality, I am now considering the design of a drum-type scanner using the same optical head described in this article. A drum-type scanner generates a linear time-position relationship for points on the document; a feature that makes it fairly simple to digitize and store the signals in a computer memory where they can be processed in a way suitable for transmission to a digital printer. In that instance, a computer program is required to convert the digital amplitude data into a constant-frequency variable-dot format for half-tone reproduction. I just hope it won't take me another 50 years to do it. R-E

FIG. 5—THE NEW PRINTER electronics is also all solid-state. A conventional reverse-connected filament transformer drive the stylus.

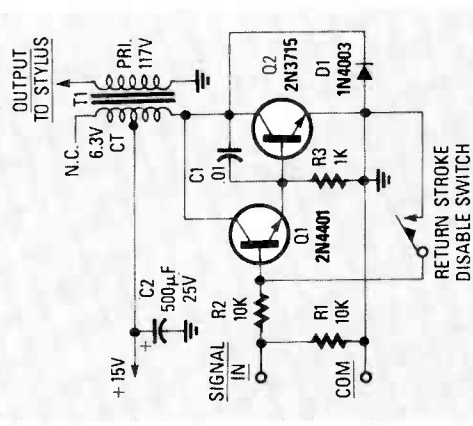

Now electronics technicians can get into VCR Servicing quickly and easily

Learn professional VCR servicing at home or in your shop with exclusive videotaped demonstrations

Today, there are more than 10 million VCRs in use, with people standing in line to have them serviced. You can bring this profitable business into your shop with NRI professional training in VCR servicing. This top-level training supports the industry's claim that the best technicians today are those who service VCRs.

Integrated Three-Way Self-Teaching Program

In one integrated program, NRI gives you a study guide, 9 instructional units, 2 hours of video training tapes accompanied by a 32-page workbook that pulls it all together. At home or in your shop, you'll cover all the basic concepts of video recording, mechanical and electronic systems analyses, and the latest troubleshooting techniques. Your workbook and instructional units also contain an abundance of diagrams, data, and supplementary material that makes them valuable additions to your servicing library.

The "How-To" Videotape

Your NRI Action Videocassette uses every modern communications technique to make learning fast and easy. You'll enjoy expert lectures and see animation and video graphics that make every point crystal-clear. You'll follow the camera eye into the heart of the VCR as step-by-step servicing techniques are shown. Both electronic and mechanical troubleshooting are covered including everything from complete replacement and adjustment of the recording heads to diagnosing microprocessor control faults.

Plus Training On All The New Video Systems

Although your course concentrates on VCRs covering Beta, VHS, and 3/4" U-Matic commercial VCRs, NRI also brings you up to speed in other key areas. You'll get training in capacitance and optical video disc players, projection TV, and video cameras. All are included to make you the complete video technician. There's even an optional final examination for NRI's VCR Professional Certificate.



Covers Beta and systems with audio instruction videotape

The Best Professional Training

This exclusive self-study course has been developed by the professionals at NRI. NRI has trained more television technicians than any other electronics school! In fact, NRI has consistently led the way in developing troubleshooting techniques for servicing virtually every piece of home entertainment equipment as it appears in the marketplace.

Satisfaction Guaranteed . . . 15-Day No-Risk Examination

Send today for the new NRI Self-Study Course in VCR Servicing for

Professionals. Examine it for 15 days, look over the lessons on videotape. If you're not fully satisfied that this is the kind of training your people need to get into a profitable VCR servicing business for a prompt and full refund including postage. Act now, and start your business to your business.

Special Introductory Offer

This complete VCR training course with two hour videotape is offered for a limited time on orders received from this advertisement at an introductory price of \$179.95. \$20 by acting now!

NRI Training For Professionals
McGraw-Hill Continuing Education Center
3939 Wisconsin Avenue, Washington, DC

YES! Get me started in profitable VCR servicing. Rush me my NRI self-study course in VCR Servicing for Professionals. I understand I may return it for a full refund within 15 days if not completely satisfied.

PLEASE SPECIFY TAPE FORMAT DESIRED VHS BETA

Name (please print) _____

Company _____

Street _____

City/State/Zip _____

Enclosed is my check money order for \$179.95 (D.C. residents add 6% tax) Make check payable to _____

Charge to VISA MasterCard _____

Interbank Number _____

Card Number _____ Expiration Date _____

Signature _____

(required for credit card sales)



NRI Training For Professionals
McGraw-Hill Continuing Education Center
3939 Wisconsin Avenue, Washington, DC

IS al n

full ple the isified ou and profit-urn it luding ng new

Offer course

on our low ave

(6

essionals g

POWERLINE MONITOR

UNTIL RECENTLY WE SAFELY could give little thought to the quality of the AC power coming out of our wall outlets. But the world is changing, and so are the power requirements of electronic equipment. Noisy, fluctuating, line power may not bother lamps, irons, or other appliances, but dirty power can raise havoc with sensitive electronic devices such as personal computers. If you have ever lost data or "trashed" a program running on your computer, you may have been a victim of a power brownout or excessive line noise, without realizing it. That could cause you to waste time troubleshooting the unit for an intermittent problem, when all that was wrong was a power glitch.

Power monitors

A power monitor lets you keep an eye on the condition of your AC power. At a glance you can read the line voltage and be aware of brownouts and surges that might damage your equipment. It even lets you monitor the relative noise level on the line; a feature that helps you spot high-noise conditions that cause equipment problems. Also, as we'll show later, a power monitor's noise-level feature lets you test line filters quickly and easily.

Although a professional-grade power monitor having those features is usually very costly, this month we'll show you a hobbyist-grade version of the device that can be built for as little as \$45. Even so, if precision components are used it can read the powerline voltage down to tenths of a volt with an accuracy that exceeds $\pm 0.5\%$. Also, relatively large 0.56-



*Solve those power problems
with this power monitor!*

GARY McCLELLAN

inch LED's displays make it easy to read the line voltage and relative noise levels at a glance.

How it works

The schematic of the circuit is shown in Fig. 1. The dashed lines represent the edges of a printed-circuit board. The lettered terminals on the dashed lines correspond to lettered solder pads on the PC-board to which the external components are connected. For example, switch S1-b

connects to solder pads on the PC board labeled A, B, and C.

The power monitor is a simple, straightforward device using an Intersil ICM71076 digital voltmeter (IC2), which reads 0-1.999 volts DC. For AC-voltage measurements, the applied voltage is simply rectified to DC before being fed to the digital voltmeter. For noise readings, a high-pass filter and peak-reading rectifier circuit are substituted for the conventional AC rectifier. A regulated power supply, IC1, provides the reference voltage needed by IC2.

The basic digital-voltmeter circuit is built around IC1 and IC2. DC inputs from the volts- or noise-measuring circuits appear across resistor R8 and capacitor C9. Those components attenuate and filter the signal from the volts- and noise-measuring circuitry. The signal is then applied to IC2, pin 31, via resistor R11 and is measured. (Resistor R11 and capacitor C10 provide overload protection for IC2.) The applied voltage is converted by IC2 into driving signals for displays DSP1 and DSP2.

A key part of the digital voltmeter is a reference voltage source from IC1. It determines the overall accuracy of the unit because IC2 makes measurements by comparing a known reference voltage with the unknown input. In this instance the reference voltage is provided by adjustable voltage regulator IC1, a low-cost adjustable voltage regulator. The regulated output voltage of 1 volt appears at the wiper of potentiometer R6 and is applied to IC2 pin 36. Because IC1 will not regulate the output voltage if too little current is drawn, resistor R4 ensures

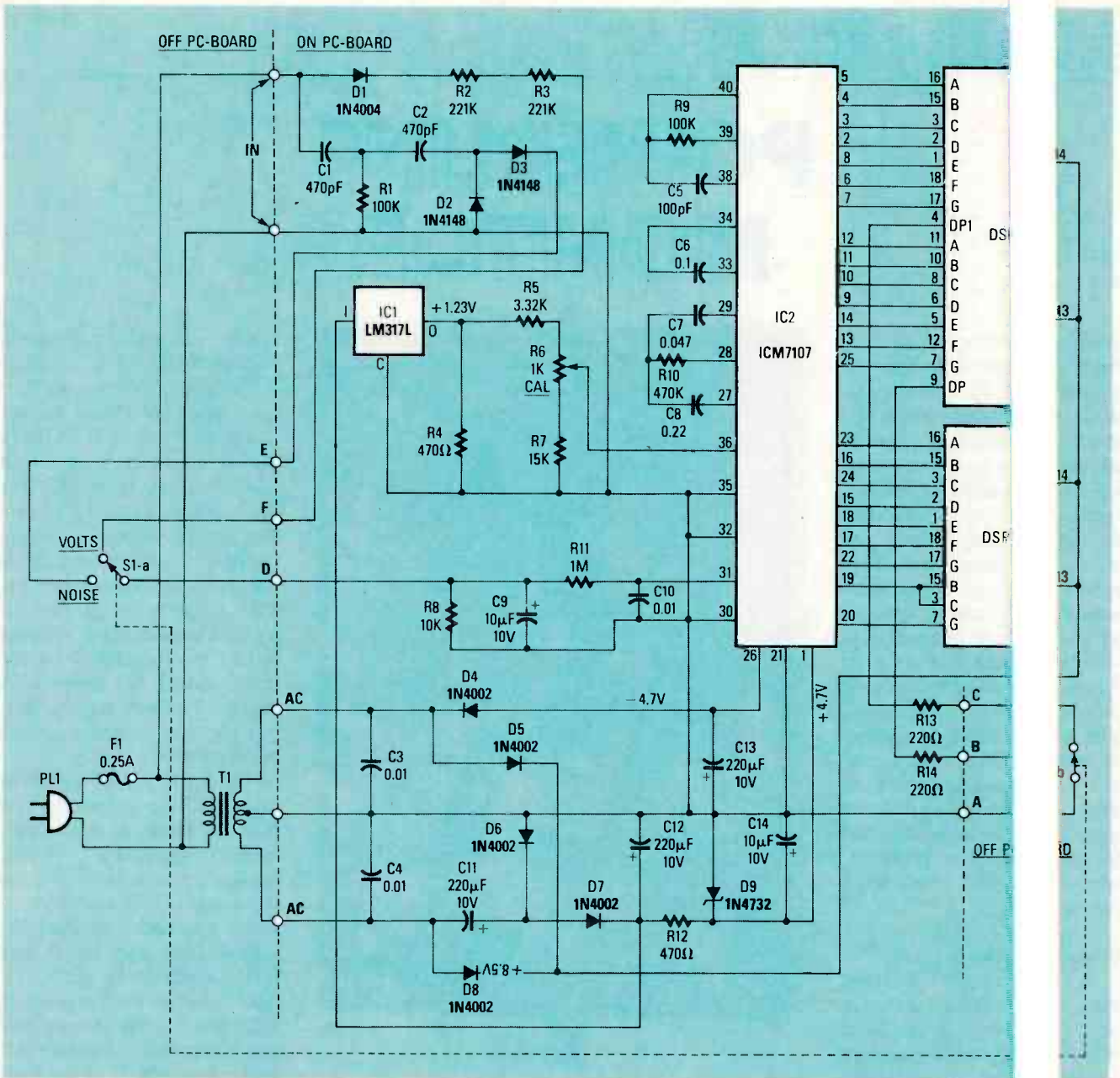

FIG. 1—THE POWER MONITOR INDICATES either the applied line voltage or the powerline noise. The noise level is determined by passing the line voltage through high-pass filter C1/R1/C2.

regulation by providing a minimum output current drain for IC1; the current loading caused by R4 ensures that IC1 will provide a constant 1.23-volt output.

The AC-voltage circuit is simple and easy to understand. Line voltage appearing across the IN terminals on the PC board is rectified by diode D1. The pulsating DC output from D1 is scaled down to the 1.2-volt range by resistors R2, R3, and R8. Capacitor C9 filters the pulsating DC so it can be measured. For improved safety and reliability, two separate resistors, R2 and R3, are used instead of a single

resistor. That is necessary because small precision resistors are usually rated at only 250 volts DC, which is marginal for use in this application.

Noise measurements

The noise-measuring circuit consists of a high-pass filter and a voltage-doubler rectifier circuit. Capacitors C1 and C2, and resistor R1, filter out the 60-Hz hum component, leaving only line noises to be measured. Diodes D2 and D3 rectify noise components into DC values. The output from D3 drives resistor R8 and charges capacitor C9 to the peak val-

ue of the noise signal.

Understand that the noise readings are relative because they are determined by the duration, shape, and peak value of the noise. In normal use, that limitation does not cause problems for the user.

The power supply

Both regulated and unregulated voltages are used. Diode D9 and capacitor C13 provide -4.7V for the analog circuitry inside IC1. Diodes D5 and D8 provide pulsating DC for powering LED displays DS1 and DS2. Using pulsating I

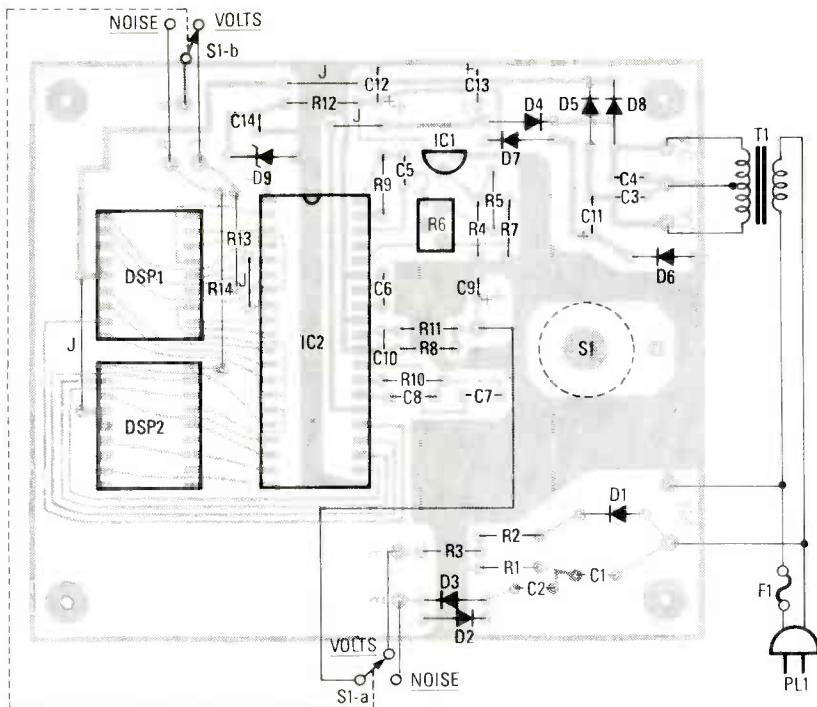

FIG. 2—USE A SOCKET FOR IC2, and do not install the IC itself until all other PC-board components are installed.

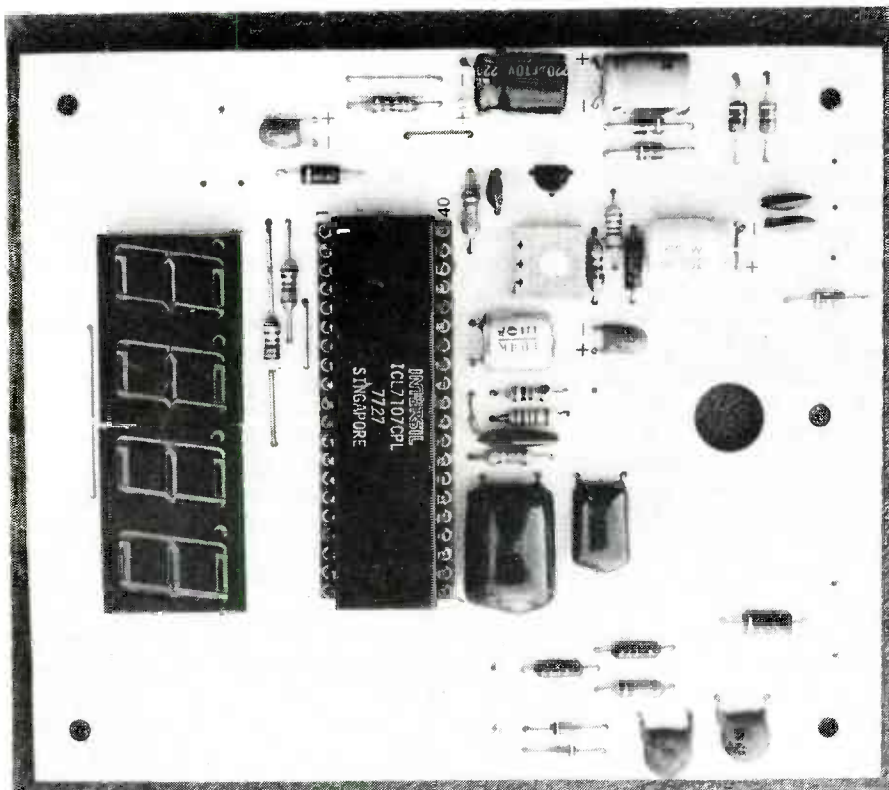

FIG. 3—FOLD THE CAPACITORS FLAT AGAINST THE BOARD to ensure clearance between the board and the cabinet. To prevent strain on the leads, bend them before soldering.

displays rather than using a steady DC voltage lowers IC2's power dissipation. Finally, a regulated +4.7-volt source for IC2 is provided via Zener diode D9.

Parts

A few parts that might prove difficult to get are the precision resistors and capacitors, and the plastic case. Precision resistors tend to be tough to

PARTS LIST

All resistors 1/4-watt, 5%, carbon film unless otherwise noted.

R1—100,000 ohms
R2, R3—221,000 ohms, 1/8-watt, 1% metal film

R4, R12—470 ohms

R5—3300 ohms, 1/8-watt, 1% metal film

R6—1000-ohm cermet trimmer potentiometer (Digi-Key OFA13)

R7—15,000 ohms, 1/8-watt, 1% metal film

R8—10,000 ohms, 1/8-watt, 1% metal film

R9—100,000 ohms

R10—470,000 ohms

R11—1 megohm

R13, R14—220 ohms

Capacitors

C1, C2—470 pF, 1000 volts, ceramic disc

C3, C4, C10—0.01 μ F, 50 volts, ceramic disc

C5—100 pF, 500 volts, ceramic disc

C6—0.1 μ F, 50 volts, polyester film

C7—0.047 μ F, 50 volts, polyester film

C8—0.22 μ F, 50 volts, polyester film

C9, C14—10 μ F, 16 volts, radial tantalum

C11—C13—220 μ F, 10 volts, radial electrolytic

Semiconductors

IC1—LM317L, voltage regulator

IC2—ICM7107CPL, A/D converter

DSP1, DSP2—Dual 0.5-inch common-anode LED display (Digi-Key P337ND or equivalent)

D1—1N4004 rectifier diode

D2, D3—1N4148 switching diode

D4—D8—1N4002 rectifier diode

D9—1N4732 Zener diode

Other components

F1—Fuse, 1/4 ampere

PL1—Linecord plug

S1—3P3P rotary switch, see text

T1—Filament transformer: 6.3 VCT, 600 mA, Stancor P-6465 or equivalent part

Miscellaneous: Cabinet, printed-circuit materials, IC socket, hardware, wire, solder, etc.

buy in small quantities from local sources, but several **Radio-Electronics** advertisers do stock them. In a pinch, you can substitute the nearest value 1/4-watt carbon-film resistors, but then the unit's precision will suffer. The polyester capacitors are widely available from many sources, but the electrolytic capacitors may prove difficult to get. You may prefer to use 220- μ F, 16-volt units and mount them on the foil side of the board where there is more room. And finally, the

simplicity, the required SO2 connections has been broken down into the wiring groups shown in Fig. 6.

Figure 6 is a top view of the SO2 20-pin header assembly. Pins 1-6 are used for the mis-dialed-digit reset pulse. (more on that a little later). Pins 7-10 are the selected unlocking digits, where pin 10 is the first digit that is entered, pin 9 is the second, pin 8 is the third, and pin 7 is the fourth and last digit.

Pins 11-20 are connected directly to the decoded decimal output from IC6, where, in the stand-by mode, they are all high.

Before any wiring can take place, determine the four-digit combination. Any digit from 0 to 9 can be used. The combination can contain double digits, such as 2 2 3 4, 4 4 9 9, etc.

For example, assume you wish to use the combination:

9 8 6 2

The combination can also be written as shown in Table 2.

As shown in Fig. 6, using jumper wires, connect header pin 19 to pin 10. That will indicate to the Tele-Guard that the number 9 will be the first digit of the unlocking sequence.

Connect header pin 18 to pin 9. That will indicate that the number 8 is to be the second unlocking digit.

Connect header pin 16 to pin 8. That indicates that the third digit is 6. Then connect header pin 12 to pin 7, indicating that the number 2 is the fourth and final digit in the four-digit combination.

The remaining SO2 wiring is the additional wiring needed for a digit-reset pulse. Connect the remaining six unused digits (pins 11, 13, 14, 15, 17, and 20) to header pins 1 through 6.

When SO2's wiring is completed and checked out, snap on the header's cover and write the combination on the cover.

The reset pulse

As stated earlier, the Tele-Guard can provide maximum security to

TABLE 2
HEADER CONNECTIONS

Digit	Place	Combination	Header Pin Number
Digit 1	9		19
Digit 2	8		18
Digit 3	6		16
Digit 4	2		12

PARTS LIST

All resistors 1/4-watt, 10%, unless otherwise noted.

- R1, R14—1000 ohms
- R2, R10-R13—220 ohms
- R3—47,000 ohms
- R4—220,000 ohms
- R5, R8—10,000 ohms
- R6, R7—120 ohms, 1 watt
- R9—1 megohm

Capacitors

- C1—2.2 μF, 250 volts, non-polarized
- C2, C4—0.22 μF, 100 volts
- C3—1000 μF, 10 volts, radial electrolytic
- C5—2.2 μF, 16 volts, axial electrolytic
- C6—0.01 μF, 100 volts, ceramic disc
- C7—47 μF, 16 volts, radial electrolytic
- C8—2200 μF, 35 volts, radial electrolytic
- C9—470 μF, 35 volts, radial electrolytic
- C10—0.22 μF, 50 volts, ceramic disc

Semiconductors

- IC1-IC3—4N33 opto-isolator
- IC4—7404 hex inverter
- IC5—M-957-01 DTMF receiver
- IC6—74154 4-to-16 decoder
- IC7—74LS30, 8-input NAND gate
- IC8, IC9—7474 dual D-type flip-flop
- IC10—LM7812 12-volt voltage regulator

- IC11—LM7806, 6-volts vol regulator

- Q1—2N4402
- D1, D2, D8-D12—1N4001
- D3-D7—1N914

- LED1-LED4—light-emitting diode, red

Other components

- PL1—modular plug with cord
- RY1—6-volts DPDT, (Digital)
- Z115-ND)
- SO1—modular telephone SO2—20-pin header with
- T1—wall transformer, 12 volts, 500 mA

- XTAL1—3.58-MHz crystal
- Miscellaneous: cabinet touch-tone telephone, printed materials, wire, etc.

Note: The following is available from Del-Phone Industries, Inc., P.O. Box 150, Elmont, New York 11003: Etched and drilled printed-circuit board \$24.; M-957-01 DTMF receiver \$15.95; 3.58-MHz DTMF crystal \$1.75. Add \$2.00 for postage and handling. New York State must add appropriate sales tax.

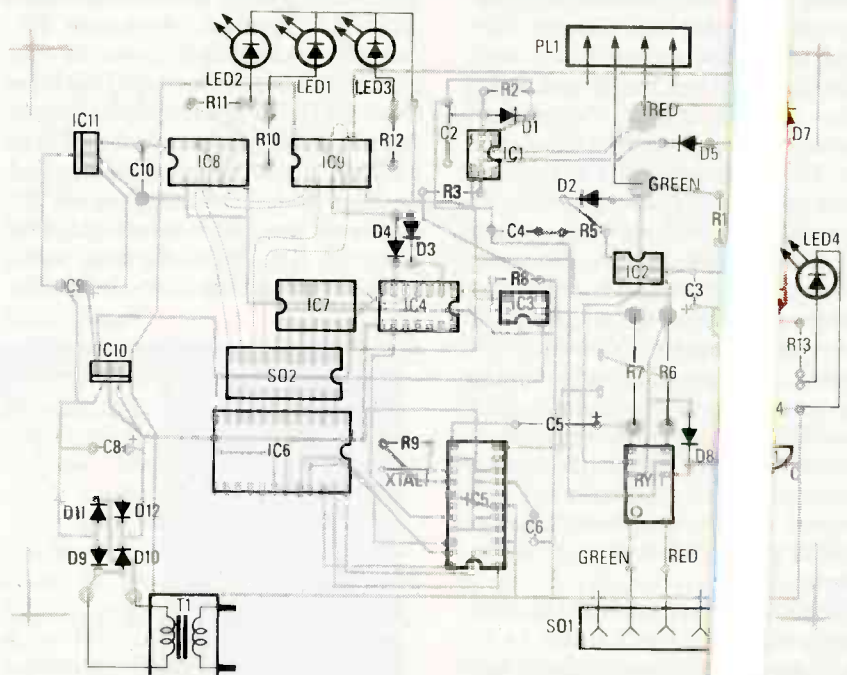

FIG. 7—THE PC BOARD is relatively large and should present no assembly problems. Just make certain LED's 1-4 are installed on the cabinet in the correct order so you can observe the correct digit entry sequence.

your telephone by making use of a circuit that will reset the D-type flip-flops (IC8 and IC9) every time an incorrect digit is entered as part of the unlocking sequence.

The heart of the reset circuit is IC7, an 8-input NAND gate. Refresh your memory of digital electronics, the output pin of a NAND gate will go high when any of its eight inputs goes low.

In the case of Tele-Guard, header pins 1-6 are connected directly to IC7. The additional two IC7 input pins, which are not used, are connected to the +6-volt power supply. In that state, all the inputs are high so the output is low.

For example, let's assume that keypad's number 9 button is pressed. That causes header-pin 19 to go low as long as the button is depressed. The jumper wire from header-pin 19 passes the low to header-pin 10, which is connected to the sequential pass-on circuitry (IC8 and IC9). At this point, all is well.

Assume that the second digit entered via the keypad is the number 3. By referring to Fig. 6, you can see that header-pin 13 is pulled low. The jumper from pin 13 pulls pin 2 low. The No. 3 digit is considered to be a mis-dialed entry because our code requires the second number dialed to be an 8, not a 3.

Since the 3 puts a low on header-pin 2, and since pin 2 is connected to one of NAND-gate IC8's inputs, IC8's output (pin 8) goes high. That high is inverted by IC4 to a low, which is passed on to IC8 and IC9 via pins 4 and 10. Both IC8 and IC9 reset when pins 4 and 10 are low, thereby canceling the previously saved unlocking-digit information. To by-pass the Tele-Guard, the user *must* enter the complete four-digit code in the proper sequence.

Visual indicator

LED's 1-4, shown in Fig. 5, provide a visual indication of the unlocking sequence. They light in sequence as the correct combination is entered. When the fourth digit is entered, LED's 1-3 extinguish and LED4 goes on, which indicates that the telephone has access to the outside telephone line.

Construction

The Tele-guard is assembled on a double-sided PC board; the templates for the board are provided in PC Service. Alternately, an etched and drilled board can be purchased from the source given in the Parts List. Take note that the PC board, whether homebrewed or purchased, does not have plated-through holes; which means that after a component is placed on the board you *must* solder a component's leads to the traces on both sides of the board.

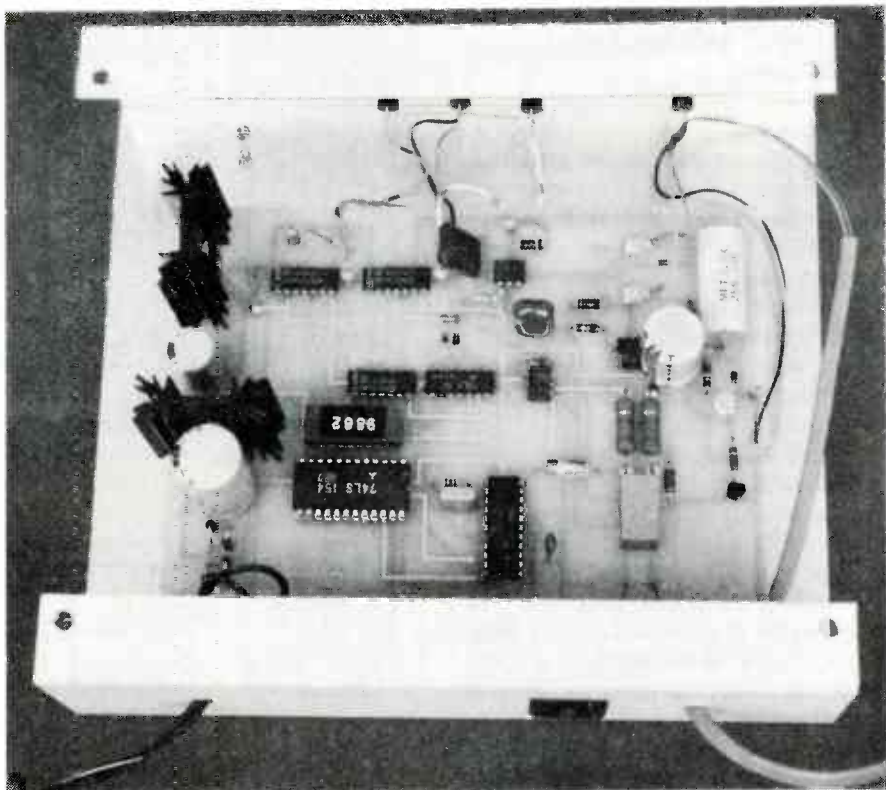

FIG. 8—SINCE NOTHING IS CRITICAL you can install the PC board in just about any kind of cabinet. Note the heat sinks attached to IC10 and IC11, which are located on the left side of the PC board.

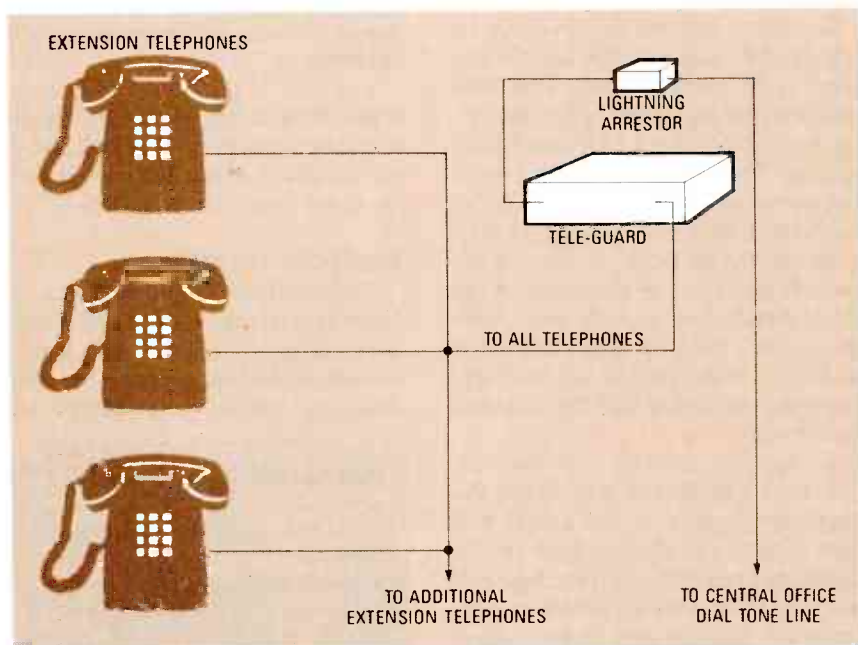

FIG. 9—WHETHER YOU HAVE ONE PHONE or several extensions, the Tele-Guard connects between the regular telephone line and all telephones connected to it.

Using Fig. 7 as a reference, install the resistors and capacitors first, then the solid-state devices and the relay. Use sockets or strip-socket sections for IC5 and IC6, and for header SO2. And make certain that you install heat sinks having at least 2¼ square-inch of area on IC10 and IC11.

To conserve space, diodes D9-D12 must be mounted standing on end. Just make sure their polarity is correct before soldering.

The completed unit can be installed in just about any kind of cabinet that you might have lying around. The cabinet that is shown in Fig. 8 was

made from a sheet of aluminum for the chassis, with wood blocks used for the sides.

Checkout

When all components are installed, soldered, and checked for proper polarity, plug in AC-wall-transformer T1 (12 to 18 VAC, 500 mA) and check for proper voltages at the power supply.

If everything checks out, connect the telephone to be secured to SO1. Then, using the keypad, key in the programmed security code and note the lighting of LED's 1-3.

When the fourth digit is entered, you should hear the relay pull in. Simultaneously, LED4 should light while LED's 1-3 go out. (The relay will only pull in and then drop out.)

Connect the red and green wires of a modular telephone cord to their proper locations on the PC board and plug the other end into the normal telephone modular wall connector.

Again, using the proper unlocking code, enter the four security digits. When the fourth digit is entered the relay will pull in and self-lock, and you will hear a dial tone in the telephone's receiver.

To further test out the operation of Tele-Guard, hang-up the telephone, then lift the handset again. This time enter the first two digits of the unlocking code. Note that LED1 and LED2 light up. Then press any other button that is *not* associated with the code. This time both LED's should go out.

To test the on-hook circuit, lift the handset and enter one or more of the digits needed to unlock your telephone; then hang up. The LED's that have just been turned on will extinguish, indicating that the counters were reset.

To test the security over-ride circuit, have a friend call you. When the telephone rings, note that LED4 will light during the ringing half of the signaling cycle. Then lift the handset; you should be able to carry on a conversation without any further action on your part.

Multi-telephone system

Figure 9 shows a multi-telephone home installation. Notice that all telephones in the home have been connected in parallel. Make certain you observe the red-green polarity but keep in mind that telephone installers have been known to make mistakes, and you may find the red and green

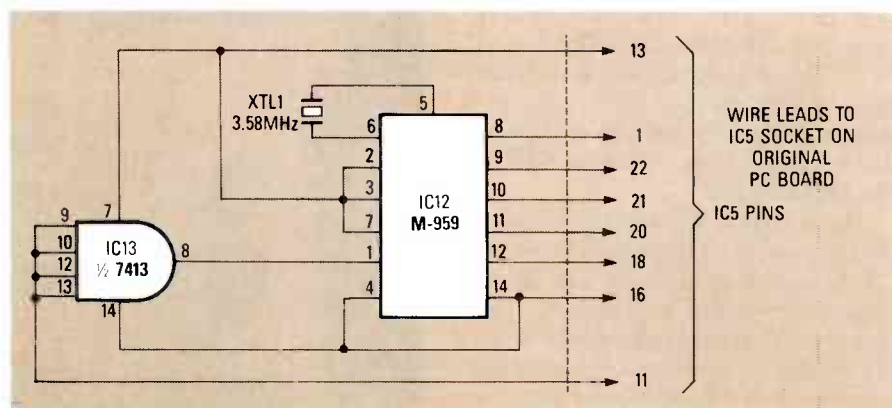

FIG. 10—THE SUBASSEMBLY CONSISTS OF only two IC's and crystal XTAL1. The crystal is the same one that's used in the DTMF version of the *Tele-Guard*.

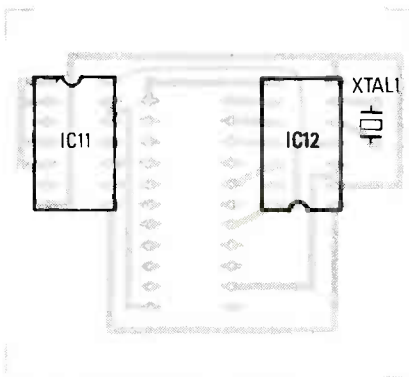

FIG. 11—THE PARTS LAYOUT for the subassembly. Make certain the IC's are positioned correctly. Their number-1 pins are opposed.

wires have been exchanged somewhere between the phone jack and the central office. If you're in doubt about the connection, check it out.

Pulse-dial retrofit

Although the *Tele-Guard* was specifically designed for use with *Touch-Tone* telephones, it can also provide the same kind of security for rotary and push-button pulse-dialed tele-

phones by simply adding a retrofit to the original project.

The retrofit consists of a few easy-to-do modifications to the original project. One of the modifications is a small subassembly, shown in Fig. 10, that substitutes for IC5—the DTMF receiver. To avoid confusion, the retrofit uses the part-number sequence from the original *Tele-Guard*; hence, the subassembly's integrated circuits are labeled IC12 and IC13.

Pulsed dialing

The heart of the subassembly is IC12, Teletone's MC-959 dial-pulse counter, which converts voltage pulses corresponding to rotary-phone dialing digits into a binary-coded output. It is essentially a direct substitute for the original DTMF receiver (IC5), except, instead of voltage pulses, the DTMF receiver converts audio tones that represent Touch-Tone digits into a binary-coded output.

IC13 is the trigger for IC12. It monitors the telephone line for dial-pulse signalling and hook status. When the telephone is on-hook, IC13's output is an active low. When the telephone goes off-hook, the output goes high, thereby triggering IC12's on/off hook and operating timers, which, in turn, trigger IC12's internal break counter, digit decoder, and output control.

Printed circuit

The subassembly is built on a small printed-circuit board. A full-scale trace template is shown in PC Service. Alternately, the PC board is included in a complete kit of retrofit parts that is available from the source given in the Parts List.

The parts layout is shown in Fig. 11. Note, in particular, that the two IC's

PARTS LIST FOR PULSE DIALER

- C11—330 μ F, 16-volt, radial-lead capacitor
- IC12—M-959, dial pulse counter
- IC13—74LS13, Schmitt trigger
- XTAL1—3.50-MHz crystal, see text
- Misc.—Printed circuit materials, wire, solder, etc.

Note: A kit containing all the retrofit parts and a printed-circuit board is available from Del-Phone Industries, Inc., P.O. Box 150, Elmont, New York 11003. Price is \$14 plus \$2 postage and handling. New York residents must add the appropriate sales tax.

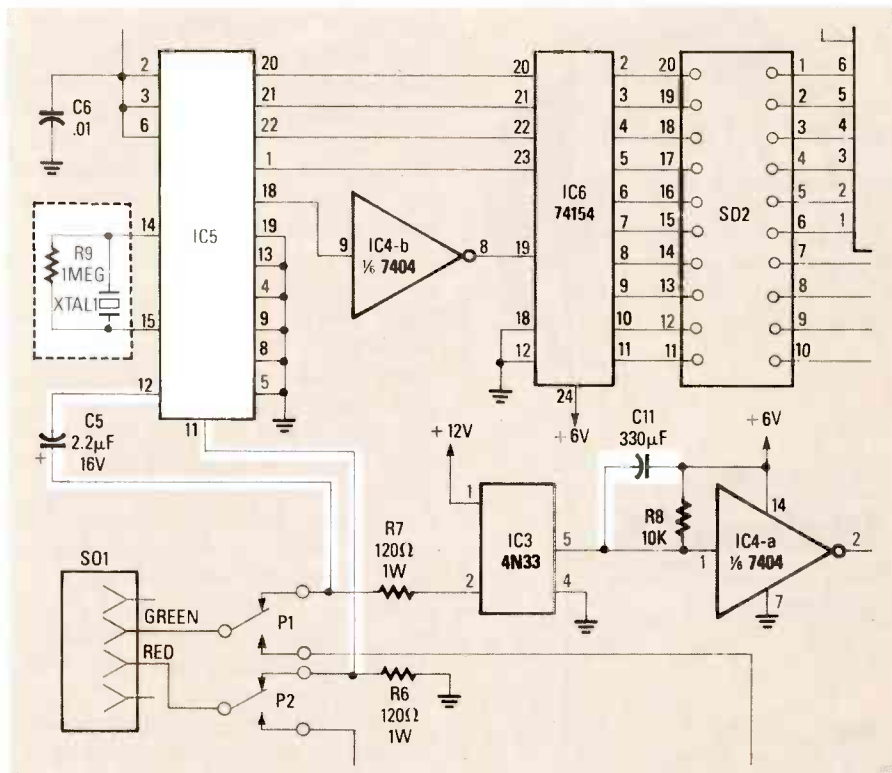

FIG. 12—THE RETROFIT'S MODIFICATIONS to the main PC board are shown highlighted. Remove R9, C5, IC5, and XTAL1. Install C11, 22 solid wires in the holes left when IC5 is removed, and a jumper from R6 to IC5's pin 11.

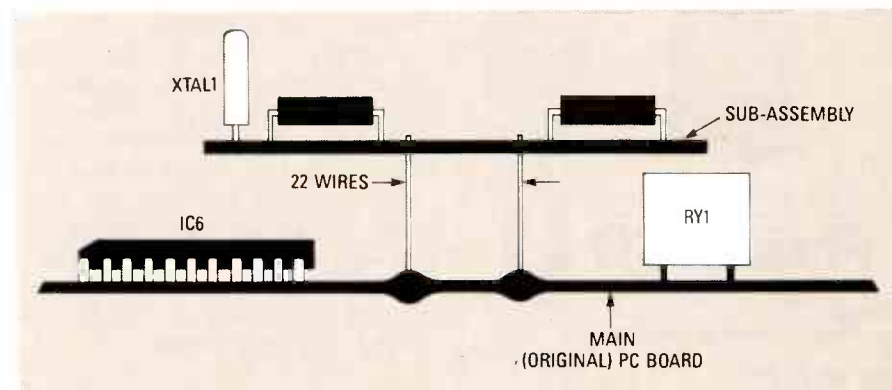

FIG. 13—SLIDE THE SUBASSEMBLY on the 22 wires sticking up from the main board. Solder the wires on both sides of the main board.

are mounted opposed; that is, pin 1 of both IC's point in opposite directions

The double row of holes on the subassembly's PC board correspond to IC5's pin pattern on the original *Tele-Guard's* PC board. (Henceforth, we will refer to the original *Tele-Guard* PC board as the *main PC board*.) Make certain that none of the holes get filled with solder during assembly. (Obviously, IC5 isn't needed if you're building the entire pulsing *Tele-Guard* from scratch.)

Complete the assembly except for the 3.58-MHz crystal, XTAL1. The crystal is the one used in the DTMF *Tele-Guard*. If you're doing a retrofit, the crystal must be removed from the

original PC board. If you're building from scratch, simply install XTAL1 directly on the subassembly.

Set the subassembly aside until you complete a few modifications to the main *Tele-Guard* PC board.

Modifications

The modifications are shown highlighted in Fig. 12. You can enter the changes on the original schematic, or photocopy Fig. 12 and paste it over the original full schematic.

From the main PC board, remove XTAL1, IC5, C5, and R9. If you remove the solder from each connection using one of the available desoldering braids, the parts will literally fall off

the board—without damage to either the parts or the printed-circuit traces. The best and the easiest solder removal will be attained using a braid about 1/8-inch wide. Double-check to be sure that every hole at IC5's location is open. Install the crystal on the subassembly's PC board.

A pulse dial actually connects and disconnects the telephone set from its line in rapid succession. If the make-break sequence wasn't compensated, the very first pulse would cause the *Tele-Guard* to disconnect the telephone from its line. To prevent an automatic disconnect, tack-solder a 330-µF/16-volt radial-lead electrolytic capacitor across resistor R8. (In keeping with our policy of using the part number sequence from the original project, the capacitor is C11.) If there is sufficient clearance between the original PC board and its metal cabinet, you can install C11 on the foil side of the board.

The polarity of C11 must be correct. When connected across R8, C11's positive lead should point toward IC4; the negative lead should point towards IC2.

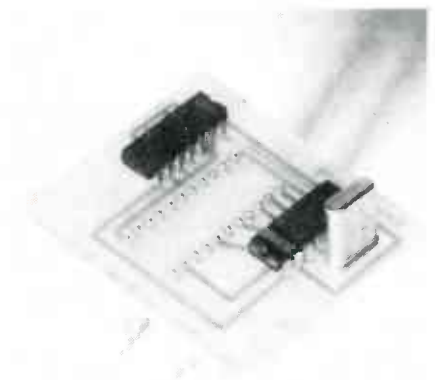

FIG. 14—THE WIRES can be pre-soldered to the subassembly first, as shown. Make certain that the wires are straight, before sliding them into the matching holes on the main board.

Install a jumper on the main PC board across the two empty solder pads that are located directly adjacent to R7 (on the side opposite R6). The jumper connects the ungrounded side of R6 to pin 11 of IC5, which is used only as an interconnect to the small subassembly.

Use Fig. 13 for reference and solder 22 solid, 1½-inch long, uninsulated wires in IC5's holes. (They will be cut to length after the subassembly is installed.) The wire size can be No. 20,

The ECG easy-to-use logic probe finds even the toughest faulty circuits!



The ECG® compact, lightweight PR21 logic probe makes troubleshooting and analyzing faulty logic circuits a snap. The PR21 is switch selectable (pulse detection or memory) and is compatible with TTL/CMOS. The PR21's other capabilities:

- responds to a pulse as narrow as 30-ns
- operates up to 20 Mhz
- audible logic state tones

The ECG PR21 is powered by the circuit being tested, eliminating the need for a battery or other external power source. Contact one of our more than 900 distributors, or call 1-800-225-8326 for the name of the distributor nearest you. It just might be the smartest call you make all week.

The Smart Choice.
PhilipsECG

A North American Philips Company
CIRCLE 250 ON FREE INFORMATION CARD

Don't let the size fool you!

The ECG® pocket-size DM-25 digital Multimeter is proof that good things come in small packages! The DM-25 offers 4 functions, 14 ranges, and utilizes a 0.5", 3½ digit LCD display. The push button, easy to use DM-25's other features include:

- 0.5% basic accuracy
- 10 megohm input resistance, DC
- overload protection
- RF shielding
- auto-polarity

The ECG DM-25 also comes with a carrying case, battery, test leads, and instruction manual. Contact one of our more than 900 distributors, or call 1-800-225-8326 for the name of the distributor nearest you. It just might be the smartest call you make all week.

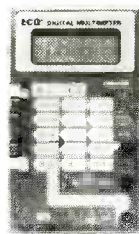

The Smart Choice.
PhilipsECG

A North American Philips Company

CIRCLE 251 ON FREE INFORMATION CARD

The ECG digital capacitance meter measures up to 20,000 uF!

The ECG® battery operated CX-920 is a highly accurate, digital capacitance meter that measures 0.1 pF to 20,000 uF over 9 ranges using a 3½ digit LCD display. And it has decimal conversions printed on the meter front for quick reference. Other features are:

- 0.5% basic accuracy
- zero adjustment
- input protected
- overrange indicator

The ECG CX-920 comes equipped with a carrying case, test leads, battery, spare fuse, and instruction manual. Contact one of our more than 900 distributors, or call 1-800-225-8326 for the name of the distributor nearest you. It just might be the smartest call you make all week.



The Smart Choice.
PhilipsECG

A North American Philips Company

CIRCLE 68 ON FREE INFORMATION CARD

22, or 24. Note, from Fig. 13, that some of the wires make connection to traces on both the top and the bottom of the main board, so make certain that you solder both sides (the holes are not plated through). After soldering the wires, bend them upward, at right angle to the board.

Again using Fig. 13 as the reference, position the subassembly directly over the 22 wires and slide the subassembly on the wires. Make certain that each wire passes through its corresponding hole. Position the subassembly so that it doesn't touch anything on the main board and then solder the wires to the subassembly's solder pads. That will complete the retrofit. (Note: If it's more convenient, install the wires on the subassembly first; then pass them through the holes in the main board. Figure 14 shows the subassembly with the wires pre-installed.)

Instead of using individual wires to connect the subassembly to the main board, you may want to use a wire-wrap IC socket. Make sure you leave enough room for soldering.

Program and checkout

Program the main PC board with the security-code for the pulse-dial *Tele-Guard* exactly as it was described for the *Touch-Tone* version. Everything else then remains the same. You gain access to the telephone line by first pulse-dialing the four-digit security code. Within a second or two a dial tone will be heard from the receiver and you then dial the desired telephone number.

Redial option

If you're using a pulse-dialing telephone having a last-number redial button, keep in mind that the telephone company's central office must deliver a dial tone before it accepts dialing pulses. If you press the redial button, your call *will not* go through, because your telephone will dial the four-digit security code and then the telephone number. The *Tele-Guard* will accept only the first four digits and connect your telephone to the line. It then takes up to two seconds for the central office to deliver dial tone; meanwhile, your telephone is still pulsing out digits. The central office, of course, will not receive any digits until the dial tone is applied. Put simply, you can't use redial with the *Tele-Guard*.

R-E

Build REACTS: THE RADIO-ELECTRONICS ADVANCED CONTROL SYSTEM

This month we show you how to add X-10 compatibility to REACTS for easy home automation.



JIM BYBEE

LAST MONTH WE BEGAN TO DISCUSS how the REACTS X-10 module works, however, as is often the case, we ran out of room and were forced to end our discussion. So, this month we continue our explanation on the X-10 module's operation. We'll also talk about the software that makes our system "tick," and then show you how to build the module so that it can become a working part of your REACTS system.

The X-10 module includes eight status LED's and eight SPST input switches. The switches, through software, can be used to turn lights and/or appliances, that are connected to X-10 modules, on or off. Likewise, the status of those appliances (whether they are on or off) can be determined by the LED's. The LED's and switches are located at one of the REACTS I/O ports. The switches are read by inputting from the port and the LED's are turned on or off by outputting the correct bit combination to the port. Since the switches and LED's are independent from the X-10 functions of the module, they are not necessarily confined for use with only the X-10 module. For example, the switches could be used to activate or deactivate the relays on the octal I/O module. The following example program illustrates that. In it we will assume that

the X-10's SPST switches are addressed to I/O port address 20, and the octal I/O relays at I/O port 55:

```
10 SWITCHES = INP(20)
20 OUT 55, SWITCHES
30 GOTO 10
```

That program would continuously input the binary value of the switches and then output that value to the relays on the octal I/O module. Each switch occupies one bit of the byte read from I/O port 20. If the switch is on, the corresponding bit will be a 1, and when the byte is sent to the octal I/O module (line 20), the corresponding relay will be activated.

Software for the X-10 module

We have already mentioned how easy it is to write programs for the REACTS X-10 module using the available driver software. Using that software, only two program lines are needed to send a command to an X-10 remote module, and one of

them is always the same—for example: GOSUB X-10. The other program line can be written in one of two ways, depending on the program mode. In mode 1, the program line is made up of a string that contains the

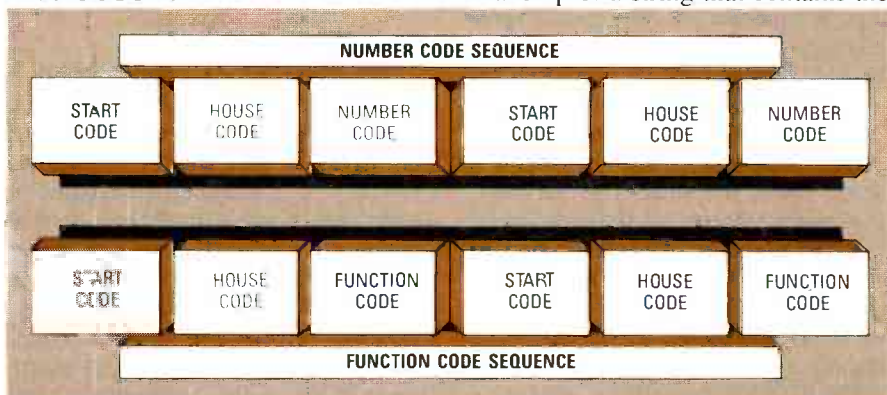

FIG. 1—EACH BIT OF THE FOUR-BIT START CODE can be transmitted on consecutive zero crossings of the AC power line. The other nine bits of each thirteen-bit word must be sent out in true form first, then in its inverse form. Each thirteen-bit word must be sent to the module at least twice.

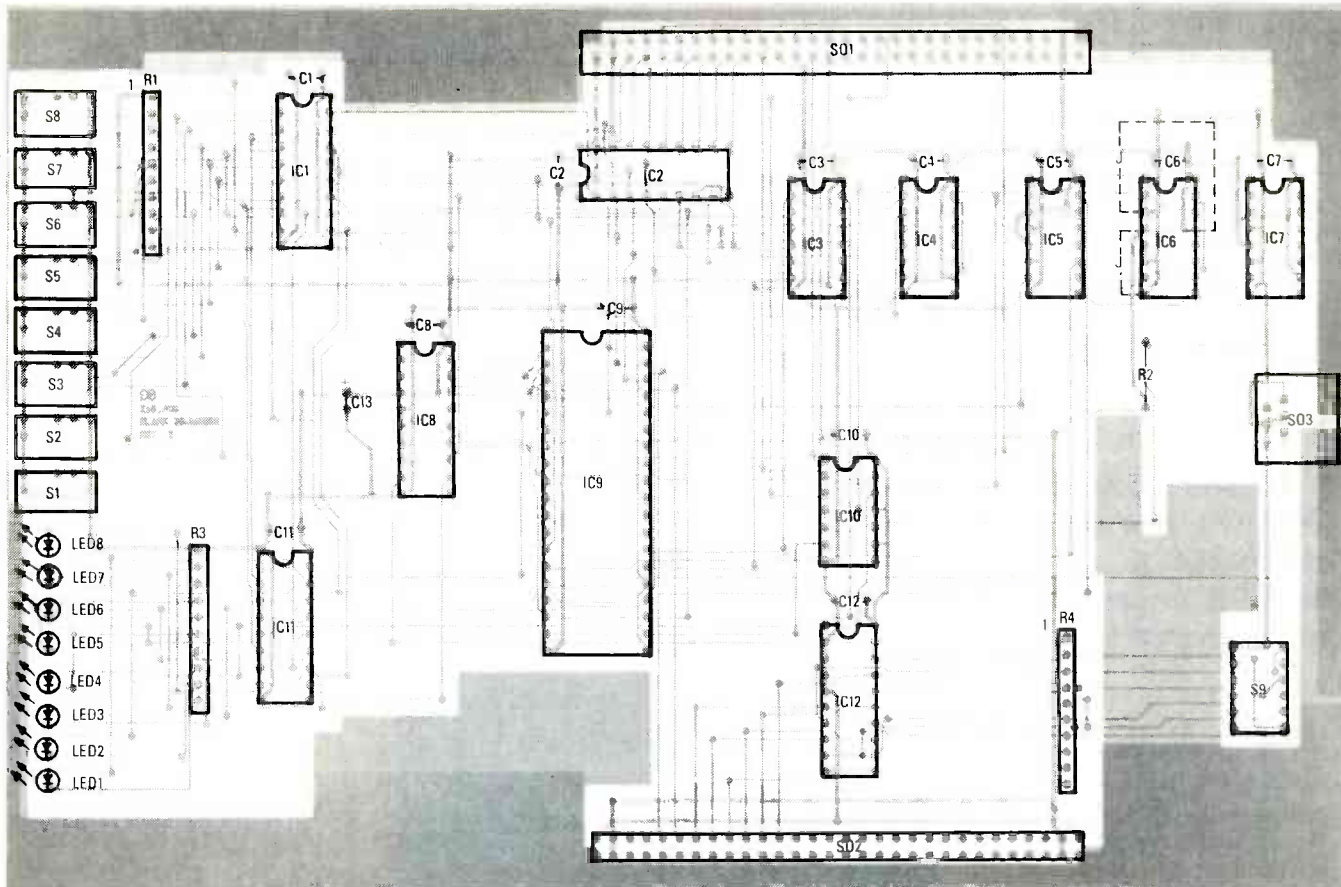

FIG. 2—PARTS-PLACEMENT DIAGRAM. Follow this when installing all parts on the X-10 board, and don't forget to use sockets for the IC's.

module's house and key codes, and the function to be performed—for example: A,2,OFF. In mode 2, the program line contains a user-defined string that represents that information—for example: MASTER BED-ROOM ON.

Outputting a control signal to a single X-10 module requires the sending of two thirteen-bit data words. The first thirteen-bit word (the number code) selects the number of the module to be controlled, and the second word (the function code) selects the type of function (on, off, dim, brighten) to be performed. The first four bits of both thirteen-bit words is a start code (1110) that is always the same. The next four bits represent the house code (A through P), and the final five select either the number of the module being selected (0 through 16) or the number of the function to be performed (on, off, dim, or bright). With the all-on and all-off functions (where all of the modules are affected), only the function code is sent.

Each bit of the four-bit start code can be transmitted on consecutive zero crossings of the AC power line. However, the other nine bits of each

thirteen-bit word must be sent out in true form first, then in its inverse form on the very next zero crossing (see Fig. 1). Additionally, each thirteen-bit word must be sent to the module at least twice.

As you can see, the actual transmitting of the codes to the X-10 remote modules is somewhat involved. However, the REACTS X-10 software handles all the details of transmitting to the X-10 remote modules, allowing you to concentrate on the main objectives of your control program.

Construction

Very little in the way of assembly is required for the X-10 module. You can purchase a complete kit of parts, or just a PC board with or without the PAL's. You'll also need a 4-conductor telephone cord with RJ14 plugs at both ends, and an X-10 PL513 Power Line Interface module. You can buy a PC board or else you can make one from the foil patterns in PC Service, and follow Fig. 2 for correct placement of all of the components. Just solder in all of the parts being sure to use sockets for the IC's. Then just press the appropriate IC's into their

respective sockets. Figure 3 shows you the completed board.

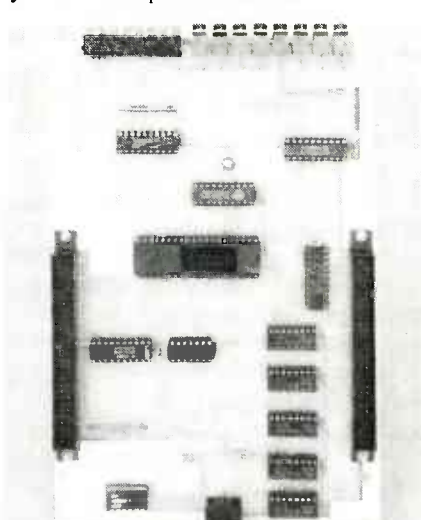
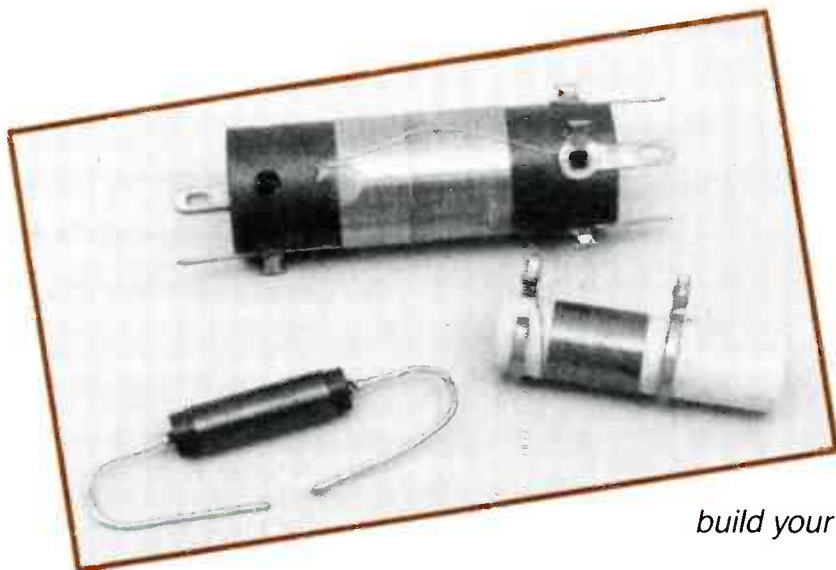

FIG. 3—THE COMPLETED BOARD. Notice the eight programmable switches.

With the REACTS X-10 interface, you take a great leap toward automating your home, and you may indeed be content with the capabilities you now have. However, we will be discussing other modules in the future, including an A/D conversion block, battery backup, and more. R-E



COPING WITH COILS

Coils of any kind can be hard to dig up. So design and build your own by using our BASIC program.

DAVID E. POWELL, KA4KNG

BACK IN THE "GOLDEN AGE" OF ELECTRONICS projects, even the local radio-repair shop often stocked an extensive assortment of RF coils. And most certainly, the major mail-order distributors, such as Lafayette and Allied Radio, stocked almost every inductor used in the civilized world. Today, however, there is little available in stock RF coils, and those that do exist can take a lot of effort to locate.

Although we have yet to develop an inexpensive solid-state substitute for coils, you don't necessarily have to give up on a radio-frequency project because your local parts distributor no longer stocks RF coils. Simply design and build the needed inductor yourself! If you have access to a computer, designing the coil shouldn't be any more complicated than typing your name if you use the BASIC program shown in Listing 1.

In fact, the only problem you might have will be to locate the needed wire type or size—because certain wire sizes can be hard to locate. But even that problem is easily resolved by our program, because you can keep plugging in the data for available wire types until the computer comes up with the needed design.

Electricity and magnetism

It is a basic characteristic of electricity that when electric current pass-

es through a wire it creates a circular magnetic field around the wire. Since the magnetic field is weak and spread out along the entire length of the wire, we would have a hard time putting the field to a good, if any, use.

But if we wind the wire into a coil, we still have the same amount of overall magnetism; only now, instead of being distributed along the length of wire, the magnetic field is concentrated into an area equal to the length and diameter of the coil. By concentrating the magnetic field into a smaller space, we have created a magnetic field that is sufficiently strong to be useful.

But a coil having a specific length, and shape produces a specific magnetic field (see Fig. 1). To increase the magnetic field, it's necessary to increase the current flowing in the wire by increasing the voltage applied across the coil.

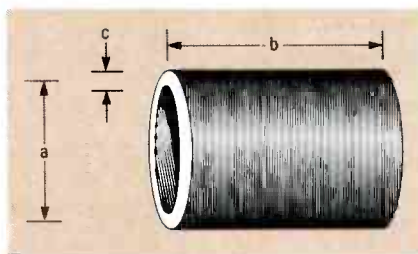

FIG. 1—THE INDUCTANCE of a coil is determined by its physical parameters (a, b, and c) and the number of turns

In a sense, the coil stores electrical energy in the magnetic field. Removing the source of electricity from the coil causes the magnetic field to collapse around the coil. As the field collapses, the magnetic lines of force cross the wires of the coil, converting the stored magnetic energy back into electrical energy. The net result is that the current developed by the collapsing magnetic field tries to keep flowing through the coil for a short period of time after the electrical source is removed. Reconnecting the source voltage has the opposite effect; that is, as the magnetic field builds up, the lines of magnetic force cross the wires of the coil in the opposite direction to the current developed by the collapsing magnetic field. That creates an opposing force to the current flowing through the wire. In other words, when the applied voltage is either AC or interrupted DC, the coil (also called an *inductor*) resists a *change* in electrical current, but not the actual current itself.

From the previous discussion, it would seem that the single most important thing we can measure about an inductor is the strength of its magnetic field. In a sense, that is true. However, the strength of the field depends on conditions external to the inductor, namely the amount of voltage applied to it. For this reason, the term *Hen-*

ry—named after the American physicist Joseph Henry—was coined to describe the electrical characteristics of inductors. The inductance of a coil is one Henry when a current variation of one ampere-per-second induces one volt of electrical opposition to current flow.

The inductor

But conditions other than the applied voltage can affect the strength of the magnetic field. If we want to increase the strength of the field without increasing the applied voltage, we can:

- Add more turns to the coil, because

more turns means more wire, which means a greater concentrated magnetic field.

- Increase the diameter of the coil, because a larger diameter means more wire, etc., etc.
- Decrease the length of the coil, because this would have the effect of concentrating the magnetic field into a smaller area, thereby making it stronger.

● Wind the coil on an iron or ferrite core, because ferromagnetic materials such as those tend to attract and concentrate magnetic lines of force.

All of the ways in which the magnetic field can be increased can be merged into a comprehensive equation for calculating the inductance of a coil. However, to both simplify our equation and eliminate the research necessary to obtain ferromagnetic values, we are going to ignore ferromagnetic permeability and such.

The equation for calculating air-core inductors, as stated by the *Radio Amateur's Handbook* is:

$$L = 0.2a^2n^2/(3a + 9b + 10c)$$

where:

L = inductance in microhenries
and as shown in Fig. 1:

a = average diameter of the coil in inches

b = length of the coil in inches

c = radial depth of the winding in inches

n = total turns of wire

Quality factor

Besides the inductance value, there is another important characteristic of a coil that we need to know about. An inductor can be thought of as an AC-only resistor, whose reactance (which can be considered as AC resistance) depends on the inductance of the coil and the frequency of the applied AC voltage. However, copper wire has a DC resistance, determined by its diameter and length. The ratio of AC reactance to DC resistance is known as the *quality factor*, or Q. For example, if an inductor has a reactance of 100 ohms at 1 kHz, and a resistance of 2 ohms, then it has a Q-factor at 1 kHz of 100/2, or 50. Of course, the Q will change with the applied frequency. To determine reactance, use the formula:

$$X_L = 2\pi fL$$

where:

X_L = the inductive reactance in ohms

π = 3.14

f = the applied frequency in hertz

L = the inductance in Henries

LISTING 1

```

100 'program to calculate the number of turns for an inductor.
110 cls:pi=3.1415926545
120 k=1473061.855 'mhos per square inch of area of copper
130 print "
140 print "
150 print "
160 print "
170 print "
180 print "
190 print "
200 print "
210 input "Desired inductance in microhenries";L
220 input "Gauge or diameter of wire in inches";diameter
230 input "Diameter of coil form in inches";form
240 if diameter >= 1 then diameter = .46 / 1.1229283027^(diameter +3)
250 print:print "calculating";
260 layers=1 'Single layer starting out

500 a=diameter*layers+form 'Average coil diameter to center of thickness
505 print ".";
510 gosub 2000 'calculate the number of turns
520 if prob=1 then layers = layers+1;if layers < 100 then goto 500
530 if b > 1 then layers=layers+1:goto 500
540 if n > 9999 then print "ERROR - turns count larger than 10000":system
550 n=cint(n):b=n*diameter/layers:ltry = (0.2 * a^2 * n^2)/(3*a+9*b+10*c)
560 w.length = n*a*pi
570 'calculate the resistance of coil
580 w.area = (diameter/2)^2*pi
590 r = 1/(w.area*k)*w.length

800 'show the results
810 print:print
815 print "Overall coil diameter..... ";diameter*layers*2+form;"inches"
820 print "Average coil diameter..... ";a;"inches"
830 print "Depth of coil..... ";layers*diameter;"inches"
840 print "Length of coil..... ";b;"inches"
850 print "Length of wire (approx).... ";int(w.length/12)"feet,;"
855 print int((w.length-int(w.length))*12);"inches"
860 print "Number of layers..... ";layers
870 print "Number of turns..... ";n
880 print "Number of turns per layer.. ";n/layers
890 print "Actual inductance..... ";ltry;"microhenries"
900 print "Coil DC resistance..... ";r;"ohms"

1000 system 'Exit the program and BASIC

2000 'subroutine to calculate the number of turns
2010 min.n=1:max.n=10000:c=layers * diameter:prob=0
2060 n=(max.n-min.n)/2+min.n
2070 b=n*diameter/layers 'length of coil
2080 ltry = (0.2 * a^2 * n^2)/(3*a+9*b+10*c)
2090 if cint(max.n) = cint(min.n) then goto 3000
2100 if min.n => 9999 then prob=1:goto 3000
2110 if ltry < L then min.n=n:goto 2060
2120 if ltry > L then max.n=n:goto 2060
3000 return

```

|| Inductor Design Calculator ||
 || by David E. Powell, KA4KNG ||

Desired inductance in microhenries? 28
 Gauge or diameter of wire in inches? .008
 Diameter of coil form in inches? .375

calculating.

Overall coil diameter.....	.391 inches
Average coil diameter.....	.383 inches
Depth of coil.....	8.000001E-03 inches
Length of coil.....	.6640001 inches
Length of wire (approx)....	8 feet, 10 inches
Number of layers.....	1
Number of turns.....	83
Number of turns per layer..	83
Actual inductance.....	28.05109 microhenries
Coil DC resistance.....	1.348764 ohms

FIG. 2—THIS IS WHAT THE SCREEN or a printout will show when the program is tested by calculating the design of a 28-microhenry inductor.

The BASIC program

Listing 1 is the BASIC program for inductor design. Although written specifically for the IBM PC, it should run on any version of BASIC. The program text is available on the RE-BBS (516-293-2283). The full name is COILS.BAS.

Lines 110 and 120 are used to set up constants for later use in calculations to determine the overall resistance of the coil.

Lines 210 through 230 input the values you specify for the desired inductance value, the size wire you have on hand, and the diameter of the coil form you're going to use. The wire size can be specified in inches or its AWG wire gauge.

Line 240 decides whether or not you entered a wire diameter or a wire gauge. If you entered a number of 1 or greater, it figures it must be a wire gauge (who would want to wind a coil with six-inch thick wire?) and converts it to a diameter.

Lines 500 through 530 are the meat of the program. It starts by assuming that you're designing a single-layer coil. Line 500 calculates the diameter

of the coil at the center of its thickness. (The diameter changes as the program adds more layers during its calculations.) Line 510 calls the subroutine that actually figures the number of turns necessary to have the specified inductance at the current number of layers. If it can't get there within 10,000 turns, line 520 adds another layer. Line 530 will add another layer if the length of the coil exceeds one inch.

Line 540 will print an error message if the required number of turns exceeds 10,000 and the number of layers is 10,000 or greater. (You really don't want to wind an inductor that big anyway.)

Line 550 rounds the number of turns to the nearest full turn. It then calculates all of the other parameters based on that rounded number. The inductor should be close enough for all but the most critical applications without having to worry about fractional turns of wire.

Line 560 calculates the approximate length of wire needed to wind the coil. The length is approximate because it is based on the average

diameter of the coil; the program does not calculate each layer of the coil independently.

Lines 570 through 590 calculate the approximate resistance of the coil, based on the length and diameter of the wire.

Lines 800 through 900 display the results of all calculations. Keep in mind that electronics is not necessarily an exact science, and that for a variety of reasons all of the displayed values could be slightly off the "true" value.

Winding the coil

The primary advantage of having a computer calculate the specifics of a coil is that we can experiment with the materials that we have on hand, trying different combinations to see how they affect the results. Recalculating the values is so easy that we should be able to get a size and shape that suits us just right.

Let's use a 28-microhenry inductor as our target value. Let's also use part of that jumbo-sized spool of 32-gauge wire that you purchased at the last hamfest. For a coil form, we can use an ordinary ballpoint pen.

Run the program. The screen should clear and ask for the needed inductance value. Enter 28.

Next, the program will ask for the size wire to be used. Enter either the gauge (32), or the diameter of the wire in inches. Since we bought this wire at a hamfest and don't really know for certain what gauge it is, we wind an inch-long close-wound coil on a pencil and count the number of turns. It turns out that our "unknown" wire requires 125 turns to fill one inch. Dividing one-inch by 125 turns gives us 0.008 inches. Enter .008.

The last prompt asks for the diameter of the coil form. We measure the thickness (the diameter) of our pen and find it is $\frac{3}{8}$ ths of an inch. Since $3 \div 8 = 0.375$, we enter .375.

If your computer has been set for printer output, you should get a hard-copy that resembles Fig. 2. If the results you attain do not match Fig. 2, re-check the program for typing errors or a misplaced decimal point.

There are a few things to note at this point about the output of the program. First, notice from Fig. 2, that there are two coil diameters given, an overall and an average.

The overall diameter is given so that you can determine (before you

Macrovision ...

now you see it, now you don't.

Remove copy-protection from video cassettes.



- Digital Filter Type, removes only Macrovision pulses
- No adjustments, crystal controlled
- Compatible with all VCR's, uses automatic vertical blanking level

Macro-Scrubber — We stock the exact parts, PC board, and AC adaptor for an article on Building a Macro-Scrubber appearing in *Radio-Electronics* December 1987 issue.

JMAK-1 Parts Package \$19.00

Includes all the original resistors, capacitors, diodes, transistors, integrated circuits, and crystal.

JMAK-2 PC Board \$9.95

Original etched and drilled silk-screened PC board used in article

JMAK-3 AC Adaptor \$7.95

Original (14 to 18 volt DC @ 285 ma) AC adaptor used in article.

Free reprint of article on building a Macro-Scrubber with any purchase above. Add \$2.50 shipping & handling; \$4.50 Canadian orders. Note: Unauthorized duplication of copyrighted material is illegal. Use Macro-Scrubber for viewing only.

72-CHANNEL

CABLE CONVERTER

WITH INFRA-RED REMOTE CONTROL

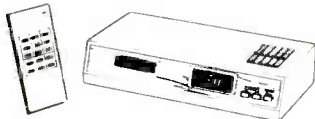

Add \$3.50 shipping & handling
\$9.50 Canadian orders.

MC-702 CONVERTER

\$79.95

- 72-channel capability
- Wireless, Infra-Red remote control
- Channel output 2 or 3 switchable
- Microprocessor controlled PLL operation
- Skip channel memory eliminates unused channels
- Parental control for all channels
- Last channel recall
- Fine tune memory
- UL listed/FCC approved
- Simple installation with any TV
- Includes battery and 3 foot coax cable

CABLEMASTER \$19.95

Cable/VCR Timer

- Record multiple premium play channels
 - Turns cable box on and off
 - Selects channel for unattended recording
 - Thousands sold nationally for \$99.95
- Add \$3.50 shipping & handling
\$4.50 Canadian orders

ORDER TOLL FREE ANYTIME

1-800-227-8529

Ask for **FREE**
Color Catalog

Inside MA: 617-695-8699

VISA, MASTERCARD,
or C.O.D.



J & W ELECTRONICS, INC.

P.O. BOX 800 • MANSFIELD, MA 02048

©Copyright 1988 by J&W Electronics Inc.

wind it) whether or not the coil will physically fit in your project. The average coil diameter is listed just in case you don't believe the computer and want to re-calculate the inductance value by hand. Second, there appears to be something amiss about the depth of the coil windings. We entered .008 for the wire thickness, and it is a single-layer coil, so the depth should be .008 inches, right? Well, the .000001 discrepancy comes from the way computers represent numbers internally. The coil-length calculation suffers from the same malady. Suffice it to say that the error is small enough to be safely ignored without affecting our end result, which is, we hope, a 28-microhenry inductor.

Speaking of 28 microhenries, Fig. 2 shows that our inductor is actually 28.05109 microhenries, instead of an even 28. That is the result of rounding the turn count to the nearest whole number. As we said earlier, electronics is not always an exact science.

The DC resistance of the inductor is given so that we can calculate the Q-factor of the coil after we decide at what frequency the inductor will be used.

Winding the coil

To make the coil, peel off about nine feet of wire from that jumbo-sized spool and start winding it on the ballpen. Make sure that the windings are even and closely spaced. Double check that the number of turns is correct.

A couple of strips of hot-melt glue across the length of the coil will hold the windings in place. If you don't have a glue gun, epoxy adhesive will do if you don't mind waiting a while for it to harden.

After the glue sets (or cools, or whatever), you should carefully slide the coil off the pen. (It would be a good idea to apply some glue to the inside of the coil to help hold the windings in place. That way you can be sure that the coil won't come apart on you when handling it.)

That's really all there is to making your own coils. From now on, not only will you save money, but you can also avoid the aggravating and time-consuming task of having to search high and low for a parts supplier that has the exact coil you're looking for—and you won't have to wait for it to come in the mail.

R-E

PC SERVICE

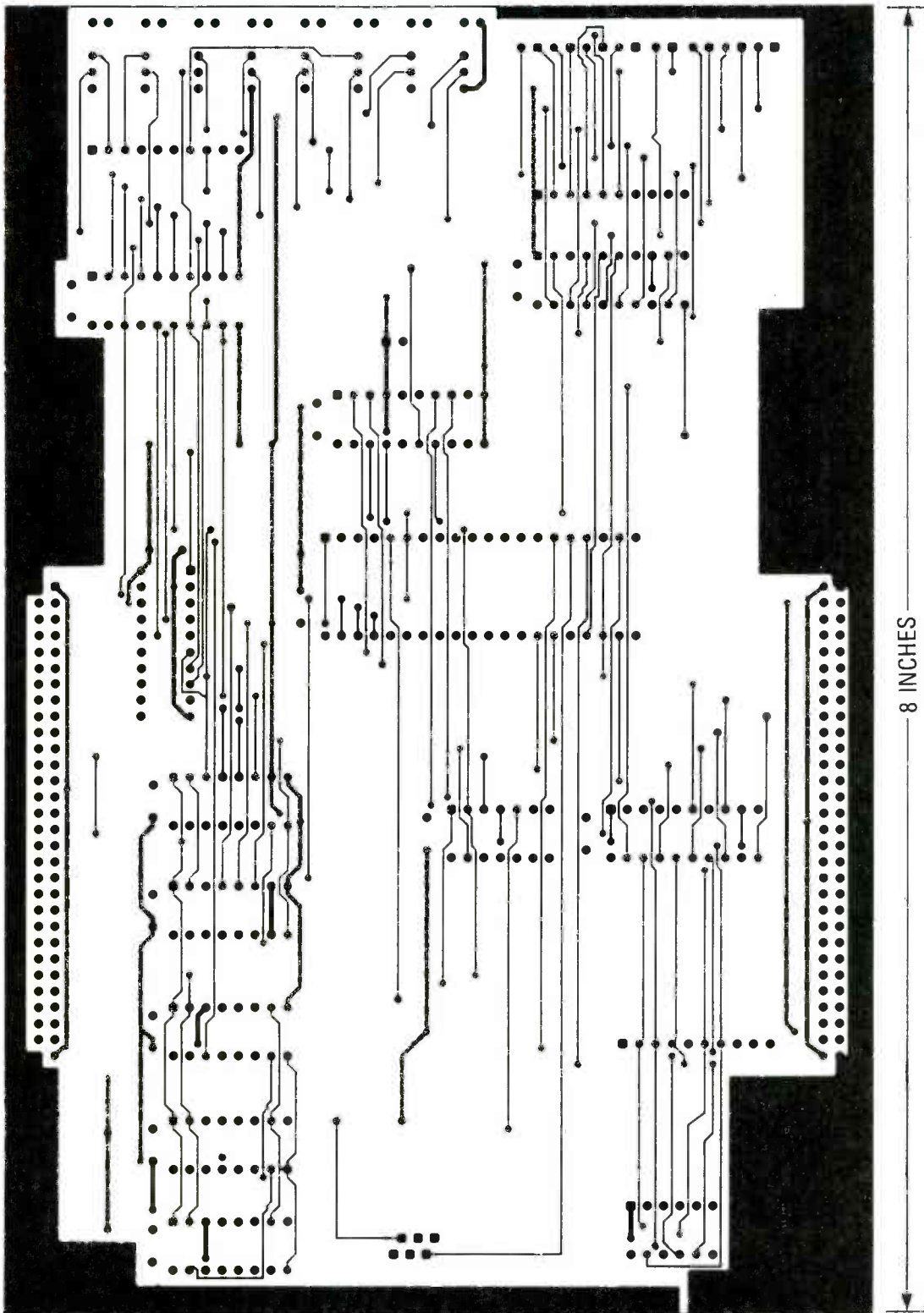

HERE IS THE SOLDER SIDE of the REACTS X10 module.

PC SERVICE

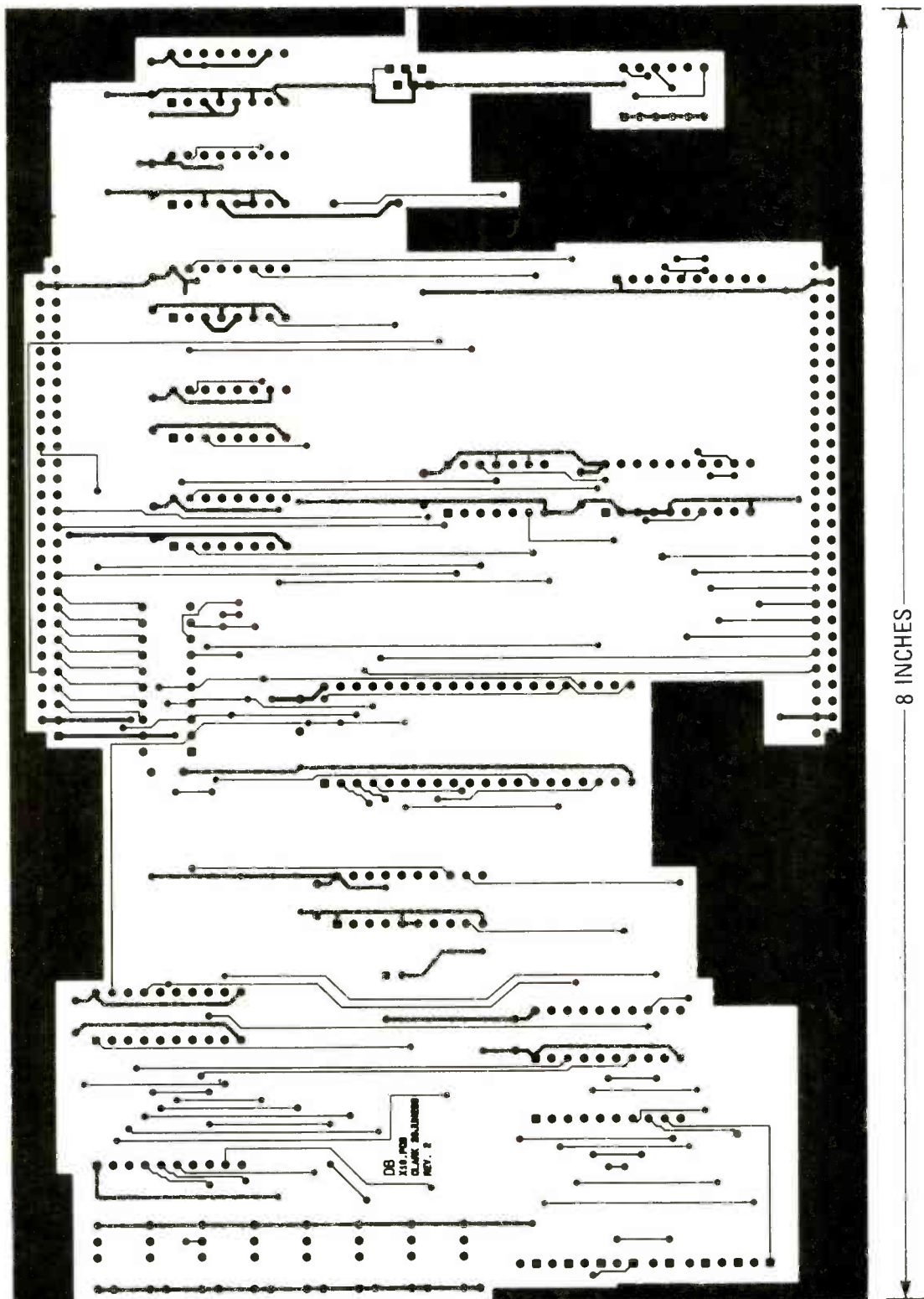

HERE IS THE COMPONENT SIDE of the REACTS X10 module.

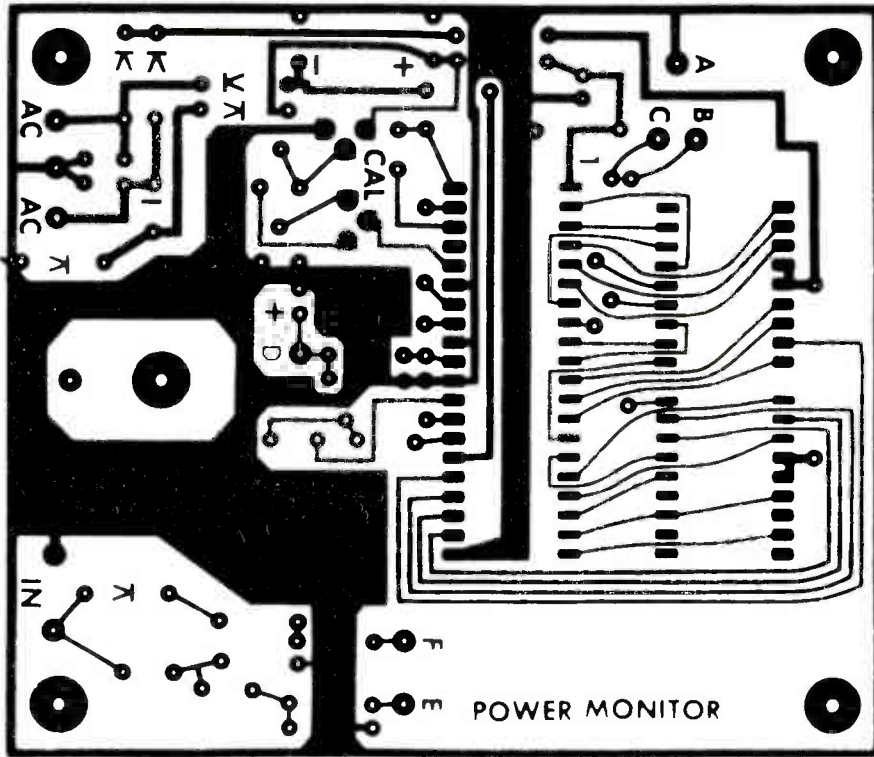

4 1/2 INCHES

THIS IS THE FOIL PATTERN for the power monitor.

More PC Service on page 97

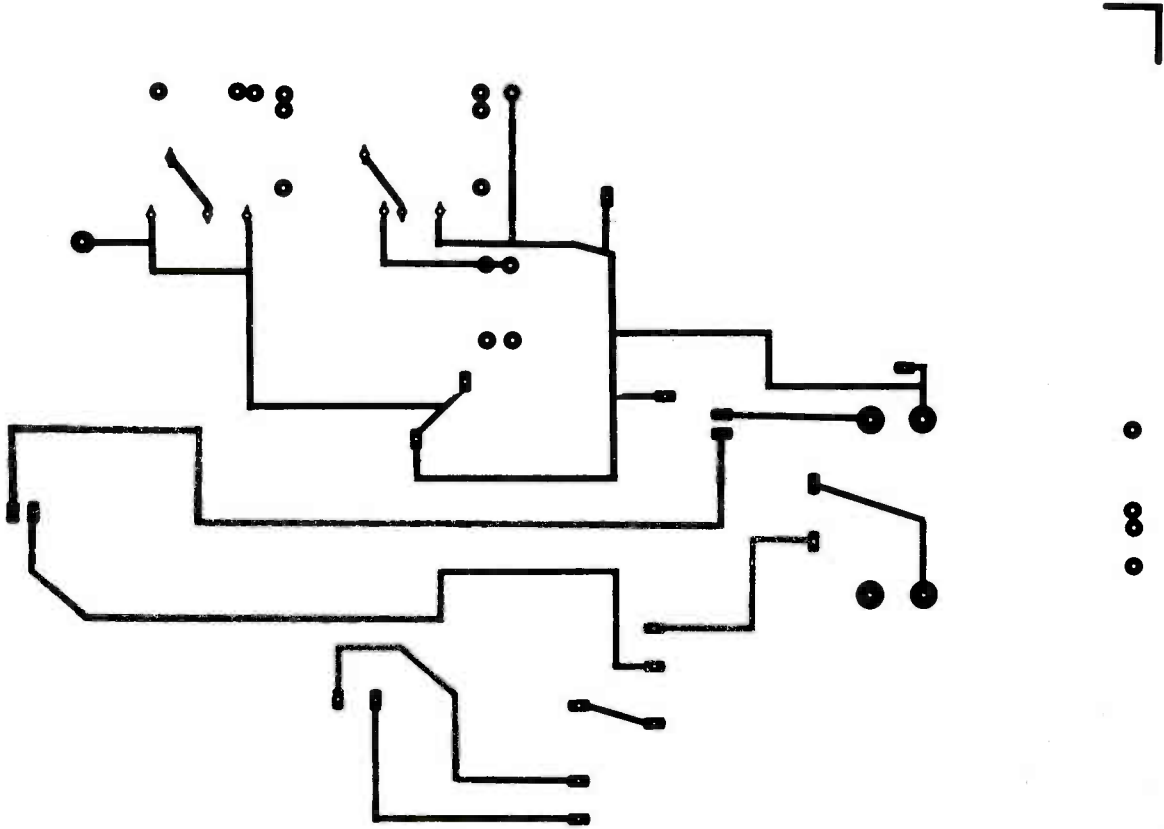

6 1/2 INCHES

THE COMPONENT SIDE of the Tele-Guard II.

DRAWING BOARD



ROBERT GROSSBLATT,
CIRCUITS EDITOR

Multiplexing and dynamic RAM

LAST MONTH WE DID NOT GET A chance to finish our discussion on multiplexing LED displays, so now we pick up where we left off. We had said that the simplest way to implement our circuit from last month would be to use an oscillator to clock a scan counter—like a 4017—that will sequentially turn on and off each LED display.

You can connect the output from last month's oscillator to pin 14 (clock input) of the 4017 IC in Fig. 1. If you set R2 and R3 to the center of rotation you'll be getting about 200 Hz with a duty cycle of close to 50%. As we had discussed, a 10-LED display needs a minimum scan frequency of about 240 Hz. When you turn the whole circuit on, all the LED's will appear to be illuminated. If you can see them strobing, decrease R2 (increase the clock frequency) until the strobing disappears.

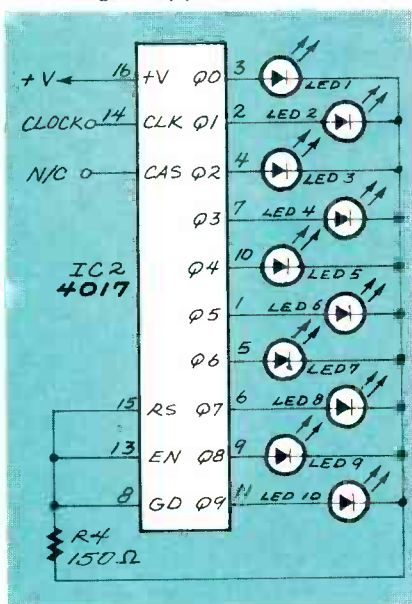

FIG. 1

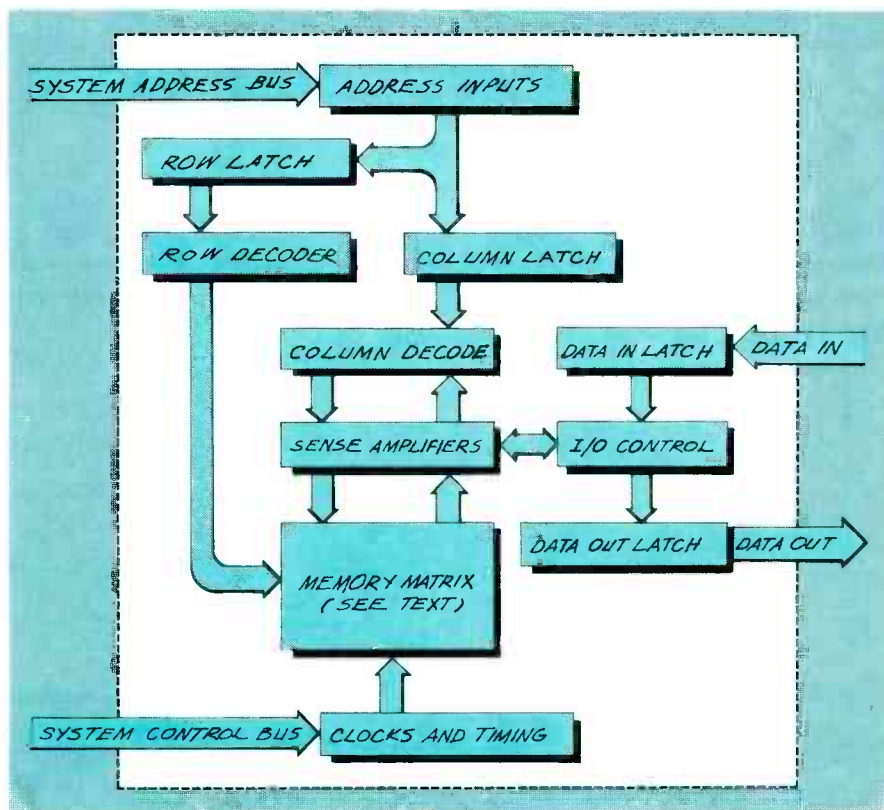

FIG. 2

If you have a frequency counter you can use it to determine the minimum clock frequency. Then try the same experiment with some other people—you'll be surprised at the variation. Some people won't see the strobing until you get below 150 Hz, and others will continue seeing it even past 300 Hz.

While you have the demonstration circuit up and running, reduce the number of LED's by connecting the pin 15 (reset) to one of the outputs while keeping the clock frequency and duty cycle constant. If you start out by setting

the frequency at a point where strobing is just evident, you'll find that the minimum flicker-free frequency decreases by about 30 Hz per LED. A 10-LED display needs about 240 Hz, a 9-LED display needs about 210 Hz, and so on.

Once again, remember that there's nothing absolute about any of the numbers I'm giving you. There's a lot of variation in biology so different people see things differently. From a practical point of view, when you're multiplexing a display you don't want to design the scan oscillator to run at the bare minimum—you should plan

DECEMBER 1988

WATCH FOR THIS ISSUE

FEATURING:

HOLIDAY LIGHT SEQUENCER

Make your home the envy of the neighborhood!

SLIDING-BAR ANTIQUE RADIO

Build a modern version of a relic from yesteryear!

SLAVE-FLASH TRIGGER

Get professional-looking flash photographs using our home-brew project!

PIEZOELECTRIC GENERATORS

Experiment with piezoelectricity, and build an eye-catching conversation piece in the process!



ON SALE OCTOBER 20, 1988 ADDITIONALLY

GIZMO

Our monthly look at what's hot in consumer electronics!

E-Z MATH

An easy-to-understand primer on the numbers of electronics!

CIRCUIT CIRCUS

HAM RADIO

DX LISTENING

COMPUTER BITS

SCANNER SCENE

ANTIQUÉ RADIO

THINK TANK

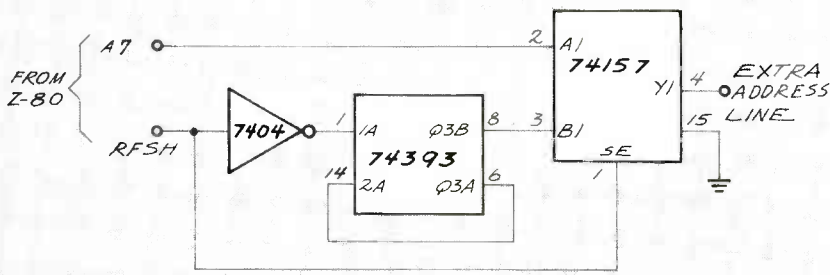

FIG. 3

on having it run much higher. Twice the minimum is a reasonable way to go. Most commercial circuits scan at more than 1 kHz, and IC's that have onboard oscillators run them at over 15 kHz. After all, you don't have to make a trip to the bank just to afford a few more Hertz!

Experiment with the circuit that we put together until you have a good understanding of the requirements of multiplexing circuitry. If you want to test how well you understand multiplexing, get the schematic for any commercial equipment having a multi-plexed

display of any kind and see if you can figure out how the circuit works.

Dynamic RAM

The series of columns I did on using dynamic RAM a while back seems to have generated a lot of interest. A couple of really good letters have come in with some questions and comments that I think are interesting enough to spend some time talking about. If you've built the system we examined, you might have had some of these in mind, so haul out your paperwork.

Keep in mind that the column space I have each month is limited so, as much as I'd like, there's just no way I can go into heavy detail about every nuance of the circuit. That also means that I can't reproduce the schematics and other drawings. The best I can do is let you know when they appeared. If you don't keep the back issues around, you can always get them from a friend, the library, or check with the Radio-Electronics reprint bookstore and see if they have the issue you're looking for.

All my drawings are done on a computer so it might be possible for them to be posted on the Radio-Electronics bulletin board. If you'd like to see that happen, let me know and we'll talk about it some more. Don't forget, however, that there's really no standard for graphics files, so you have to let me know what format you'd like the files to be. That is a function of the software you're using and the type of computer you're using so include that information in your letter.

SCIENTIFIC ATLANTA AND PIONEER CABLE CONVERTERS IN STOCK AC/DC — The New Leader in Low Prices			
ITEM	1 UNIT	5+ UNITS	
PIONEER ADD ON PD 2	275.00	250.00	
PANASONIC WIRELESS CONVERTER 1403N	79.95	69.00	
JET HOLID 400 WITH FILM MOTE (MANUAL FINE TUNING)	84.95	55.00	
JET HOLID 400 COMBO W/ FILM MOTE (DIP/SW/C)	134.95	100.00	
JET HOLID 450 COMBO W/ FILM MOTE (DIP/SW/C)	169.95	125.00	
JET HOLID 400 OF 450 REMOTE TRAND UNIT	24.95	15.00	
JET HOLID SSI ADD ON	74.95	55.00	
JET HOLID SSI ADD ON WITH TR-01	95.00	75.00	
QAK M 36 COMBO	94.95	65.00	
QAK MINICODE (N-12)	84.95	59.00	
QAK E CONOCODE (E-13)	84.95	40.00	
FRAMER MLD-1200	84.95	55.00	
EAGLE PD 3	90.95	60.00	
ZI WITH SSI/AVI CABLE READY	149.95	100.00	
SCIENTIFIC ATLANTA SA-3 ADD ON	106.95	80.00	
INTELLIFENCE FILTER (CHANNEL 3 OR 6)	24.95	14.00	
VIDEO TAPE COPY STABILIZER	69.95	45.00	
PANASONIC CONVERTER W/ VOLUME CONTROL (170 3PB)	109.95	50.00	
SCIENTIFIC ATLANTA 63 CHANNEL CONVERTER	89.95	75.00	
SCIENTIFIC ATLANTA SMART TR MOTIF	89.95	49.00	
PIONEER CONVERTER (4535)	89.95	75.00	

QUANTITY	ITEM	OUTPUT CHANNEL	PRICE EACH	TOTAL PRICE

NO NEW YORK SALES. It is not the intent of AC/DC to defraud any pay television operator and we will not assist any company or individual in doing so.

PLEASE PRINT: Cashier's Check Money Order COD

Name _____

Address _____

City / State / Zip _____

Signature _____ Phone Number () _____

WAIVER: Since I, the undersigned, fully understand that the ownership of a cable decoder does not give the owner of the decoder the right to decode or view premium cable channels without proper authorization from their local cable company, hereby declare under penalty of perjury that all products purchased, at any time, will only be used on cable TV systems with proper authorization from local officials or cable company officials in accordance with all applicable federal and state laws. Federal and various state laws provide for substantial criminal and civil penalties for unauthorized use.

Dated: _____ Signed: _____

ATLANTIC CABLE DISTRIBUTING CENTER INC.
 P.O. BOX 278 — GREENVALE, NY 11548
 516 - 625-3550 **IMPORTANT:** Have make and model of the equipment used in your area. 516 - 625-3532

TOP OF THE LINE

METERS

FLUKE

23 3 1/2 Digit DMM \$137.

73 3 1/2 Digit DMM 69.

75 3 1/2 Digit DMM 99.

77 3 1/2 Digit DMM 128.

83 3 1/2 Digit DMM 189.

85 3 1/2 Digit DMM 219.

87 4 1/2 Digit DMM true RMS 259.

8060A 4 1/2 Digit DMM true RMS 323.

8062A 4 1/2 Digit DMM true RMS 260.

37 Bench portable DMS 217.

8010A Bench portable true RMS 255.

8050A Bench portable true RMS 349.

FULL LINE AVAILABLE

BECKMAN

DM10 3 1/2 Digit DMM \$39.

DM73 Probe DMM Auto-ranging beeper, data hold 65.

TECH350 Bench DMM with beeper and more 222.

HD151 Pocket DMM auto-ranging 149.

HD152 3 1/2 Digit DMM auto-rang 169.

HD153 3 1/2 Digit DMM auto-rang 199.

DM850 4 1/2" digit, frequency counter, data hold 207.83

Tech300 Diode Test 113.00

Tech330 True RMS, Diode Test 206.00

SCOPES

HITACHI Hitachi

3 Years Manufacturers Warranty parts & labor

V-212 20 MHz dual trace scope \$385.

V-423 40 MHz dual trace delayed sweep scope 795.

V-660 80 MHz dual trace scope

V-665 60 MHz dual trace cursor readout scope

V-1060 100 MHz dual trace scope

V-1065 100 MHz cursor readout scope

V-8020 20 MHz digital storage scope

BECKMAN

9020 20MHz dual trace scope, component tester, delayed sweep 520.

IC TESTER

B & K

560 programmable IC tester \$2970.

POWER SUPPLIES

Viz

WP-703A Single 0-20VDC (r 0-500MA, single meter 146.

WP-704A Single 0-40VDC (r 0-250MA, single meter 146.

"We ship anywhere. Your satisfaction is our main concern."

Lisa S. Hadar V.P., C.P.A.

—WE CARRY—

- *Soldering Supplies
- *Electronic Parts
- *Electrical Supplies
- *Test Instruments
- *Electronic Kits
- *Printed Circuit Material
- *Tools

SOLDERING SUPPLIES

Unger

UTC 100 Temperature controlled soldering system

4024 De-soldering service station 414.

9000 Temperature controlled soldering station 208.

6970 HD Heat gun (gives 1000 watts) 72.

1095 Heat gun (gives 1000 watts) 35.

FREE CATALOG

KELVIN ELECTRONICS

7 FAIRCHILD AVE. **1-800-645-9212**

PLAINVIEW, N.Y. 11803 (516) 349-7620 FAX: (516) 349-7830

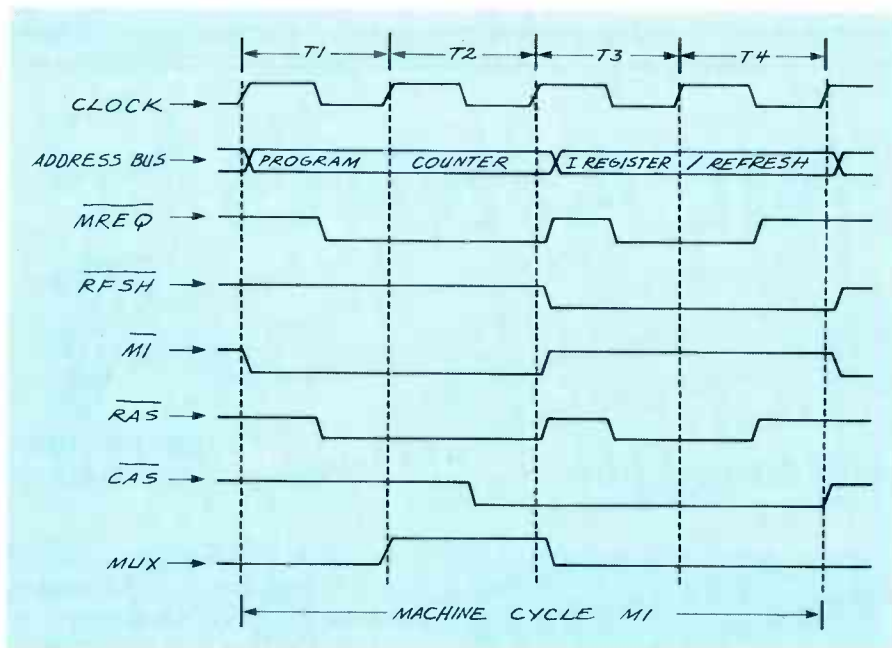

FIG. 4

But, onward.....

Matt Allen from Santa Clara, California pointed out a possible problem concerning the choice of dynamic RAM for use with the Z-80. Since the Z-80 has a modu-

lo-7-counter for refresh addresses, it uses only lines A0-A6 when it puts the refresh address on the bus. That was covered in detail in the May and June 1988 issues.

The problem that Matt is refer-

ring to comes about because a lot of DRAM manufacturers make parts that want eight lines driven in every refresh cycle. If you're unlucky enough to get your hands on some of those parts, any data you write into the upper half of the memory is going to disappear almost as soon as you put it there.

Not a good thing.

The reason for all of that aggravation comes about because of the internal architecture of the 4164. Figure 2. shows the basic DRAM arrangement and, while all manufacturers use the same basic arrangement when they make the DRAM, the little details can, and often do, differ. And as is clearly stated in a well-known variation of Grossblatt's sixteenth law: It's the little things that get you—since they're harder to see and there are more of them.

Nobody screws around with success, so every mainstream DRAM made is going to have sense amplifiers, decoders, latches, etc., and, unless you're buying your

continued on page 99

BEST PRICES!
Freight and taxes extra.
Immediate availability.

800-624-6241
Call toll free to order.
Use your VISA or MasterCard!

MULTIMETERS		SCOPES		POWER SOURCES	
Beckman Industrial		Hitachi		Power Designs	
Model	Price	Model	Price	Model	Price
300	\$101	V-222	\$570	2020B	\$808
310	\$122	V-422	\$734	1570A	\$1515
320	\$150	V-425	\$859	2K20A	\$1040
350	\$198	V-1100A	\$2070	4050D	\$765
360	\$250	V-660	\$1076	5015D	\$508
4410	\$206	V-665	\$1345	6150D	\$765
HD100	\$146	V-1060	\$1436	TW347D	\$812
HD110	\$172	V-1065	\$1706	TW5005D	\$594
HD130	\$224	V-509	\$1266	TW6050D	\$1021
HD140	\$241			TP340A	\$725
Fluke		Iwatsu		TP343A	\$812
Model	Price	Model	Price	LCR METERS	
23-YEL	\$125	DS-6411	\$2414	Wayne Kerr	
25-YEL	\$167	DS-6121	\$3975	Model	Price
27-YEL	\$208	SS-5702	\$508	4225	\$1806
27-STD	\$208	SS-5705	\$853	4210	\$2497
37	\$209	SS-6611	\$1863	COUNTERS	
73	\$66	SS-5711	\$1634	Fluke	
75	\$100	SS-6122	\$2065	Model	Price
77	\$125	SS-5712	\$2885	1900A	\$459
8010A	\$251	THERMOMETER		1910A	\$616
8020B	\$176	Fluke (Handheld)		1911A	\$756
8050A	\$335	Model	Price	1912A	\$832
8060A	\$310	52	\$142		

Used Test Equipment, Too! Over 3,000 Models Available At Huge Discounts With Warranties!

United States Instrument Rentals, Inc.
A U.S. Leasing Company

Use VISA or MasterCard
Call 800-624-6241

The Only Universal Back Tension Gauge

Tension cassettes work on less than half the VHS machines now in the field.

The Tentel® T2-H7-UM Tentelometer® is so universal, it will work on all brands and models of VHS recorders and allows the accuracy to be easily verified in the field. Tension measurements are made out in the tape path near the heads where tension is important. Tape tension can cause a number of problems difficult to correct when you're only guessing. Stop guessing, do it right!

Ask about Tentel's **NEW T.E.S.T. Cassette** for use with the Tentelometer. This **NEW T.E.S.T. Cassette** (Patent Pending) offers a fast, complete performance evaluation of holdback tension and the entire tension servo system; to determine if it is maintained in the 23 to 35 gram specification.

T2-H7-UM - \$325 T.E.S.T. Cassette/VHS - \$29

Call our toll free number or send for complete details on these and Tentel's other VCR test gauges. We make the difficult easy... to help you!

TENTEL® Corp. (800) 538-6894
1506 Dell Avenue
Campbell, CA 95008 In Calif. - (408) 379-1881

COMMUNICATIONS CORNER



HERB FRIEDMAN,
COMMUNICATIONS EDITOR

Double your modem's data throughput.

THE MAIN SUBJECT OF THIS MONTH'S column is Class-5 modems, a way to double a modem's throughput without doubling the baud rate. But before we get to the esoteric stuff, let's tackle a simple problem that causes more trouble than the whole subject is worth.

Silicon diodes cost a manufacturer next to nothing. Yet, judging by the mail and phone calls we get, there is still a lot of modern hardware out there that is back in the stone-age of telecommunications because a manufacturer didn't use four itty-bitty diodes.

From electronic telephones, to burglar-alarm telephone dialers, to add-your-own-anything devices, some hardware still contains warnings to the effect that if the equipment doesn't work you should check the polarity of the telephone connections. The reason for the warning is that all or part of the gizmo is powered by the telephone line, which under normal circumstances is negative polarity on the red wire and positive on the green. Unfortunately, sometimes the two can be reversed, and a polarity-sensitive device won't work.

Auto polarity

It is precisely to get around the polarity problem, that most manufacturers of active-circuit equipment intended for use on the dial-up telephone system (what we call *the switched network*) use a bridge rectifier between the line and the input to the electronic gizmo. As shown in Fig. 1, a bridge rectifier, D1-D4, automatically provides the correct polarity. The

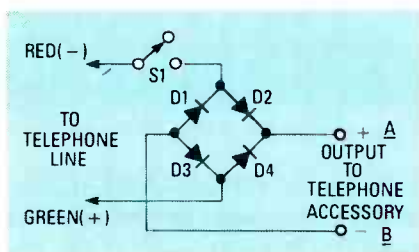

FIG. 1

bridge can be made from silicon rectifiers of the 4000 series rated at 200 PIV or higher.

Check it out for yourself: Whether the red wire is negative or positive, the output at terminals A and B always have the same polarity—although the output voltage will be from 0.5 to 1 volt less than the input voltage because of the internal voltage drop of two diodes. If your gizmo is extremely voltage-sensitive, or if the normal voltage drop of your telephone when loaded is unusually severe, the voltage drop may prove to be a problem. If so, you've probably got some problem with the line that should be corrected by your local telephone company. Switch S1 is a hookswitch, or whatever switch connects the gizmo to the telephone line.

Doubling the data

Computerists have always searched for, or at the very least wanted, a faster and more accurate way to exchange data via the dial-up telephone system. Initially, both needs were easily accomplished by increasing the baud rate used by the modems, and by using special error-correction software, such as XMODEM and

CROSSTALK. Through software handshaking between the sending and the receiving computers, errors induced in a data transmission were detected with excellent accuracy. When an error did occur the data was retransmitted until the handshake signals indicated that the block of data was received error-free.

As far as modem speed is concerned, there is a practical limit of about 2400 baud for full-duplex hassle-free exchange using asynchronous transmission. Although experiments have shown that full-duplex operation as high as 9600 baud is possible on the dial-up system, baud rates higher than 2400 are not really reliable.

It was to ensure automatic error-correction and increase the throughput that the Class-5 modem protocol was developed. Basically, Class-5 modems contain their own error-correction firmware (*firmware* meaning software that's permanently built into a device), and hardware data compression which, depending on the particular kind of data transmitted, can almost double the amount of data throughput. In practical terms, it means that a modem running at 1200 baud will appear to be running at 2400 baud, while a 2400-baud modem will exchange data at a 4800 baud effective rate.

The throughput increase comes about in two ways. First, the software, known as an MNP protocol, converts the asynchronous data to synchronous data, making the signal bit- rather than byte-oriented. Although MNP removes the start and stop framing bits for a 20%

increase in data handling, MNP needs about 12% in bit overhead, so the effective increase due to software is about 8%. In other words, allowing for worst-case conditions, MNP has an efficiency of about 108%, while conventional software protocols have an efficiency of about 90%.

Admittedly, 108% is no great improvement, but MNP is the firmware from what's known as Class-3 protocol. Class 5 includes data compression, and that's where the big increase comes in.

The amount of data compression depends on the type of data being exchanged. For example, if the data is ASCII text, an increase of almost 100% (doubling the throughput) is possible. If the data is random, such as a program file or already compressed data, there will be little, if any, improvement.

Data compression works by sampling characters. When three or more of the same character is repeated, the firmware strips the redundant characters and tabulates the stripping, continually up-



FIG. 2

dating the tabulation. At the receiving end, the Class-5 modem uses the tabulation data to restore the original, noncompressed, data.

Faster drive

To ensure the maximum possible data-transfer rate, the Class-5 modem must be driven with at least twice the data so there can be no delay in the modem's output. That is done by having the computer drive the modem at a baud rate at least twice that of the modem. As shown in Fig. 2, if the modem is operating at 1200 baud, the computer must drive the modem at 2400 baud. Internal RAM in the modem stores the "extra" data until it can be compressed and transmitted.

The same thing happens at the receiving end. Also, as shown in Fig. 2, if the data is received at 1200 baud, it's going to come out of the modem decompressed at an effective 2400-baud rate. To ensure that the maximum compression throughput is maintained, it has become common practice to use a 9600-baud rate between the computer and the modem, since 9600 baud will even accommodate a normal modem speed of 2400 baud, and possibly 4800-baud modems (if they ever make a serious dent in the marketplace). Whatever modem speed you decide to use, just bear in mind that at the very least, the baud rate of the computer's serial port must be at least twice the normal baud rate of the modem. **R-E**

KEEP IN TOUCH!

Stay in touch with the technology that is affecting our everyday lives. Four new books, easy-to-understand

for the reader who wants to learn and remain up-to-date with products impacted by new technology.

Electronic Life-Style is about electronic products that are touching our lives. It helps make sense out of the latest high-tech products, in non-technical language. This book tells what the products do and how they do it, and helps you to better use and enjoy them. Fully illustrated with photos in full color. 160 Pages, Softcover. **\$14.95**



With over 2500 modern technology terms and abbreviations, over 150 of them with illustrations, the **Technology Dictionary** is a source of knowledge for terms and definitions covering the high-technology world of electronics, computers, telecommunications, video and consumer electronics. Clear, understandable, easy to read. **\$7.95** 176 Pages, Softcover.

Need help in deciding on telephone services? **Save On Telephone Services for Home and Business** provides the answers. It discusses what services are provided by local and long distance telephone companies, and tells you how to choose and manage these services. Learn about the present nationwide telephone companies different telecommunications networks. 168 Pages, Softcover. **\$9.95**



Using Video in Your Home provides knowledge and understanding of the latest video products and what functions they provide — TV receivers, monitors, VCRs, video players, video cameras and camcorders, video systems interconnections and even a troubleshooting guide — in clear everyday language. 176 Pages, Softcover. **\$12.95**

QUANTITIES		
_____	400-32 Electronic Life-Style @ \$14.95	= _____
_____	400-31 Save On Telephone Services @ \$9.95	= _____
_____	400-03 Technology Dictionary @ \$7.95	= _____
_____	400-04 Using Video in Your Home @ \$12.95	= _____
_____	TOTAL Shipping and handling per book @ \$1.50	= _____
	SUBTOTAL	_____
	TAX*	_____
	TOTAL	_____

Mail check or money order to: Master Publishing, Inc., 14 Canyon Creek Village, MS 31, Richardson, Texas 75080. Orders in Continental U.S. shipped prepaid. Foreign orders: Prepay in U.S. funds, include shipping costs. Prices subject to change without notice.

Name _____

Address _____

City _____ State _____ Zip _____

*Texas residents add state and local sales tax on subtotal.

RE 128

Master Publishing, Inc.

© 1988 Master Publishing, Inc.

NOVEMBER 1988

New Scanner by AOR

100 Channels
800 MHz



• Includes antenna, rechargeable battery, charger/adaptor & belt clip. Full range of optional accessories available.

• Covers 27-54 MHz, 108-174 MHz, 406-512 MHz, and 800-950 MHz.

• 5 Scan Banks and 5 Search Banks.

• 25 Day Satisfaction Guarantee. Full Refund if not Satisfied.

• No Frequencies cut out.

• Size: 2" x 5 3/4" x 1 1/2" wt: 12 oz.

AR900

Total Price, Freight Prepaid
(Express Shipping Optional)

\$299.00



COMMUNICATIONS

10707 E. 106th St. Indpls., IN 46256

Toll Free 800-445-7717

Visa and MasterCard

(COD slightly higher)

In Indiana 317-849-2570 Collect FAX (317) 849-8794

CIRCLE 204 ON FREE INFORMATION CARD

Be an FCC LICENSED ELECTRONIC TECHNICIAN!



No costly School. No commuting to class. The Original Home-Study course prepares you for the "FCC Commercial Radio-telephone License". This valuable license is your "ticket" to thousands of exciting jobs in Communications, Radio-TV, Microwave, Computers, Radar, Avionics and more! You don't need a college degree to qualify, but you do need an FCC License.

No Need to Quit Your Job or Go To School This proven course is easy, fast and low cost! **GUARANTEED PASS** — You get your FCC License or money refunded. **Send for FREE facts now. MAIL COUPON TODAY!**

COMMAND PRODUCTIONS

FCC LICENSE TRAINING, Dept. 90
P.O. Box 2824, San Francisco, CA 94126

Please rush FREE details immediately!

NAME

ADDRESS

CITY

STATE

ZIP

HARDWARE HACKER

continued from page 36

Industrial shopper resources

As long-term Hardware Hacker readers have already found out, I am very big on trade journals. As we have seen in the past, the free electronic and other trade magazines are outstanding resources that no serious hacker can afford to ignore, even for an instant.

This month, I'd like to make you aware of a sub-class of the trade journals that we might call the *Industrial Shoppers*, and otherwise well known by their universal slang term of "the throwaways."

They are almost always oversize magazines printed on slick newsprint and contain mostly zillions of ads and a few bingo cards. Their editorial materials are primarily press releases and rehashes of their advertiser's product line and literature.

While almost a nuisance in any large electronics house, the throwaways are extremely valuable for hackers and small-scale operations in general.

Here's a sample list of a few of the many throwaways that passed through my *Synergetics* international corporate offices last week: *Pollution Equipment News*; *Electronic Components News*; *Plant Sites and Parks* (Great for free maps, but don't tell them I told you so), *Computer Products*; *Automatic ID News*; *Industrial Product Bulletin*; *Industrial Equipment News*; *Instrumentation and Control News*; *Industrial Maintenance*; *American Laboratory*; *Computer Reseller News*; and one called *Electronic Buyers News*.

There are zillions more where those came from.

As with all other trade journals, you can get a complete list of names and numbers from the *Uhlrichts Periodicals Dictionary* that's on the reference shelf at your local library. A phone call or a business letter can get you a qualification card.

Or, to reveal a best-kept insiders secret, you can get a free copy of most any magazine simply by requesting a sample copy and an advertiser's rate card. Sometimes that even gets you a long-term

complimentary subscription. But don't tell them who told you that.

Throwaways on such obscure things as blacksmithing, dentistry, forestry, jewelry, on ranch management, for pollution controls, solar contracting, or heavy-equipment maintenance can often open up whole new worlds of ideas and products for you.

Check them all out. And never leave any industrial plant ever without ripping out the qualification cards from all of the industrial magazines in their lobby.

New tech info

The new *Murata-Erie* short-form catalog has all sorts of neat hacker goodies in it, including ceramic resonators, posistors, humidity sensors, and ultrasonic microphones. Additionally, *NEC* has released a data sheet on their new *uPC1870CA* single-chip television stereo MTS decoder.

National Semiconductor offers a brand new *Semiconductor Master Selection Guide*, while the brand new *Avantek Product Guide* has all sorts of info in it for microwave transistors and on their MMIC integrated circuits.

A new *Linear Integrated Circuits Databook* from *Unitrode* has lots of ap notes and specialized circuits in it, aimed primarily at switching-mode power supplies. In particular, you might want to check out their *UC3906* intelligent battery-charger chip and ap note.

There's also a high-energy little shopper out called *Nuts and Volts* that is crammed full of electronics and computer classified bargains. That gem is chock full of outstanding hardware-hacking buys and is a "must have."

Turning to my own products, if you are at all interested in active filters, do check into my classic *Active Filter Cookbook*. Auto-graphed copies are now available from *Synergetics*. Plus a reminder that my *PostScript Printed Circuit Layout Package* is now available to work along with most any word processor on pretty near any personal computer.

And yes, we should shortly have full sets of the *Hardware Hacker* reprints available. Write or call if you are interested.

Let's hear from you.

R-E

AUDIO UPDATE

continued from page 43

about 5 minutes have been essentially solved. However, I think it's safe to say that, as with so many other "good ideas," the ultimate commercial success or failure of this one has little to do with its technical feasibility. The basic question is: Who in the music business is potentially going to make more—or less—profit as a result of this new development—and how much power would the various potential winners or losers have to promote or hinder its adoption?

From a retailer's point of view, it seems very appealing to have the equivalent of an enormous—and inexhaustible—stock of singles and albums available in a machine that (perhaps) takes up no more space than a standard home refrigerator (see Fig. 1). Servicing and updating the machine should be no more complicated than with today's jukeboxes. According to my latest information, the cost of the customized cassette will be about \$1 a song. That seems reasonable, but I suspect that many home tapers enjoy the compilation process and wouldn't want to trade the satisfaction for one-stop convenience. Is the Personics machine the wave of the future or is it just another technically good idea that simply doesn't dovetail with the perceived social-economic needs of the marketplace? More AES papers next month. R-E



This has to be what you ordered, Pal—our Computer doesn't make mistakes. . .

Radio-Electronics mini-ADS

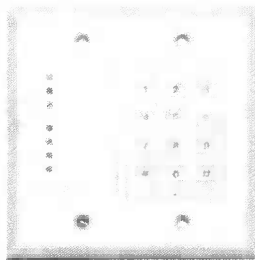

BECOME A WHOLESALE DEALER FOR all types of security electronic equipment and more. Controls, motion detectors, switches, sirens, CCTV, etc. Buy wholesale and make extra money reselling or installing alarm and surveillance systems. System examples and installation tips. Also built-in sound systems, intercom, vacuum systems. Call toll-free for catalog or write to: **ACS SUPPLY CO. INC., 2531 Jefferson NE, Albuquerque, NM 87110. 1-800-545-6286. \$9.95, + 3.00 Postage and handling if COD.**

CIRCLE 193 ON FREE INFORMATION CARD



RADR GUNS & SYSTEMS FOR CAR/BOAT racing, skiing, baseball, etc. Professional X & K band police models available from **\$275** used. Moving units available with dual displays. All units road tested with 30-day warranty. ZENITH SSAVI UHF from **\$169**; ch.3. in **\$229**, reconditioned. UHF SSAVI project handbook **\$6.50** ppd. Used Sylvania 4040 w/remote **\$169**. N-12s **\$99**. Panasonic multi-line telephone systems from **\$675**. Catalog **\$1**. **AIS SATELLITE, INC., 106 N. 7th St./N, Perkaspie, PA 18944. 215-453-1400.**

CIRCLE 81 ON FREE INFORMATION CARD

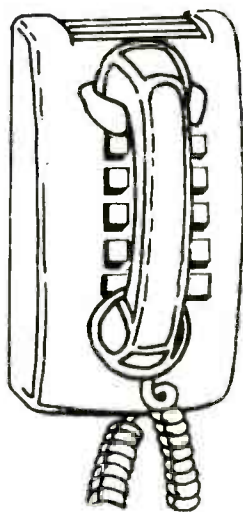

APPLIANCE REPAIR HANDBOOKS—13 volumes by service experts; easy-to-understand diagrams, illustrations. For major appliances (air conditioners, refrigerators, washers, dryers, microwaves, etc.), elec. housewares, personal-care appliances. Basics of solid state, setting up shop, test instruments. **\$2.65 to \$7.90** each. Free brochure. **APPLIANCE SERVICE, P.O. Box 789, Lombard, IL 60148. (312) 932-9550.**

CIRCLE 84 ON FREE INFORMATION CARD

CALL NOW AND RESERVE YOUR SPACE

- 6 × rate \$890.00 per each insertion.
- Fast reader service cycle.
- Short lead time for the placement of ads.
- We typeset and layout the ad at no additional charge.

Call **516-293-3000** to reserve space. Ask for Arline Fishman. Limited number of pages available. Mail materials to: mini-ADS, RADIO-ELECTRONICS, 500-B Bi-County Blvd., Farmingdale, NY 11735.

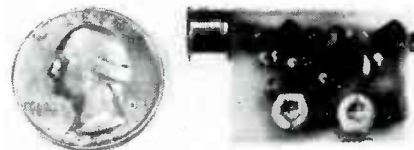

SIMPLY SNAP THE WAT-50 MINIATURE FM TRANSMITTER on top of a 9v battery and hear every sound in an entire house up to 1 mile away! Adjustable from 70-130 MHZ. Use with any FM radio. Complete kit **\$29.95 + \$1.50 S + H**. Free shipping on 2 or more! COD add **\$4**. Call or send VISA, MC, MO. **DECO INDUSTRIES, Box 607, Bedford Hills, NY 10507. (914) 232-3878.**

CIRCLE 127 ON FREE INFORMATION CARD

Radio-Electronics mini-ADS



FREE CATALOG OF HARD-TO-FIND TOOLS is packed with more than 2000 quality items. Your single source for precision tools used by electronic technicians, engineers, instrument mechanics, schools, laboratories and government agencies. Also contains Jensen's line of more than 40 tool kits. Send for your free copy today! **JENSEN TOOLS INC., 7815 46th St., Phoenix, AZ 85044. (602) 968-6231.**

CIRCLE 115 ON FREE INFORMATION CARD



M-BREAKOUT SOLVES RS-232 COMPATIBILITY PROBLEMS FAST!!! • Breaks/re-directs all 25 signals • 52 LED's give 4-state indication on all signals • Current loop test • No batteries required • Gold plated contacts • 8 jumper cables • Durable ABS plastic case • Manual and carrying pouch • We ship UPS 2nd day within 24 hours of order • Regularly \$150, R&E Special \$135, **M-TEST EQUIPMENT, P.O. Box 146008, San Francisco, CA 94114-6008, (415) 861-2382 FAX (415) 864-1076**

CIRCLE 182 ON FREE INFORMATION CARD

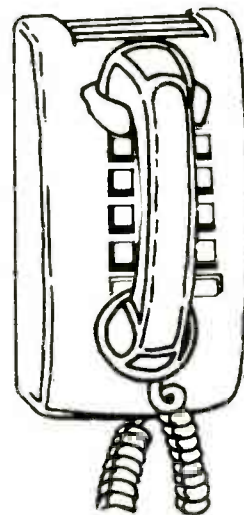

CALL NOW AND RESERVE YOUR SPACE

- 6 x rate \$890.00 per each insertion.
- Fast reader service cycle.
- Short lead time for the placement of ads.
- We typeset and layout the ad at no additional charge.

Call 516-293-3000 to reserve space. Ask for Arline Fishman. Limited number of pages available. Mail materials to: mini-ADS, RADIO-ELECTRONICS, 500-B Bi-County Blvd., Farmingdale, NY 11735.

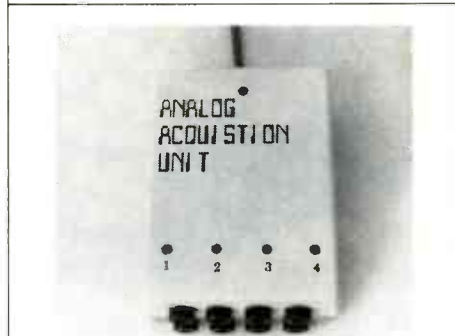

ANALOG ACQUISITION UNIT. CONNECT analog signals from experiments and circuits directly to your computer. Works with IBM, APPLE, TANDY or any computer with a serial port. 4 channels, 8 bit resolution. Up to 4 samples per second. Returns value in HEX or Decimal. **\$129.95** Check, Visa or Mastercard accepted. **GTC INDUSTRIES, PO BOX 2493, NAPERVILLE, IL. 60566 (312) 369-9815**



THE MODEL WTT-20 IS ONLY THE SIZE OF A DIME, yet transmits both sides of a telephone conversation to any FM radio with crystal clarity. Telephone line powered - never needs a battery! Up to ¼ mile range. Adjustable from 70-130 MHZ. Complete kit **\$29.95 + \$1.50 S + H.** Free Shipping on 2 or more! COD add \$4. Call or send VISA, MC, MO. **DECO INDUSTRIES, Box 607, Bedford Hills, NY 10507. (914) 232-3878.**

CIRCLE 127 ON FREE INFORMATION CARD

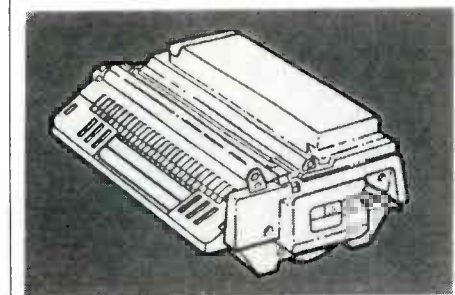

RECHARGE LASER PRINTER TONER CARTRIDGES—Earn big \$\$ in your spare time—All supplies and Do-It-Yourself kits with complete instructions available. Supplies cost from **\$10.95** in qty and you can sell recharged toner cartridges for **\$40.00 to \$55.00** each. Printers include HP LaserJet and Series II, Apple LaserWriter, QMS, etc. Canon PC-25 Copier also. **CHENESKO PRODUCTS, 21 Maple St., Centereach, NY 11720, 516-736-7977, Fax: 516-732-4650**

CIRCLE 190 ON FREE INFORMATION CARD



PANASONIC CABLE CONVERTERS, Wholesale and Retail. Scientific Atlanta and Pioneer Cable Converters in stock. Panasonic model 140N 68 channel converter **\$79.95.** Panasonic Amplified Video Control Switch Model VCS-1 **\$59.95.** Scientific Atlanta Brand new Model #8528 550MHZ 80 Channels Converter **\$89.95.** Video Corrector (MACRO, COPYGUARD, DIGITAL) ENHANCER **\$89.95.** We ship to Puerto Rico, Caribbean countries, & So. Amer. Write or call **BLUE STAR IND., 4712 AVE. N, Dept 105, Brooklyn, NY 11234. Phone (718) 258-9495.**

CIRCLE 85 ON FREE INFORMATION CARD



2645T—117 PRACTICAL IC PROJECTS YOU CAN BUILD.....\$10.95. Dozens of fully-tested, ready-to-build circuits you can put together from readily-available, low cost IC's! There are a total of 117 IC circuits ranging from an audio mixer and a signal splitter to a tape-deck amplifier and a top-octave generator organ! From TAB Books. **To order your copy send \$10.95 plus \$2.75 shipping to Electronic Technology Today Inc., P.O. Box 240, Massapequa Park, NY 11762-0240**

A NEW KIND OF MAGAZINE FOR ELECTRONICS PROFESSIONALS

EIA-232

A real standard for serial interfacing?

Page 87

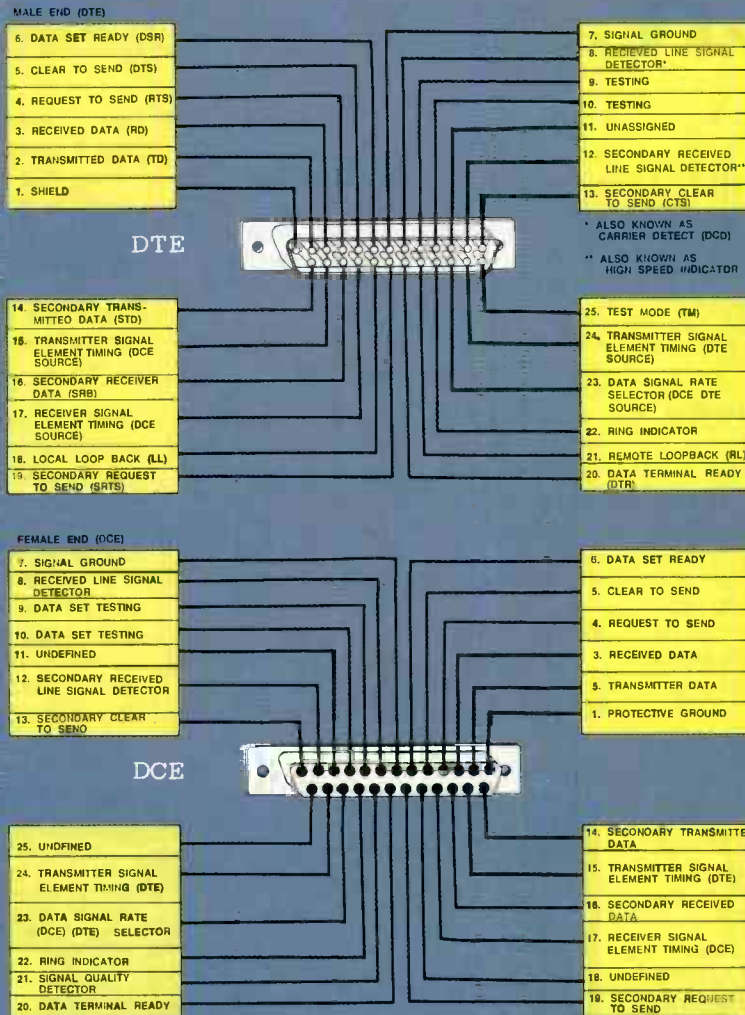

A
GERNSBACK
PUBLICATION

THE SYNERGY CARD

Finish it up and put it to work

Page 90

ADVANCED FLOPPY DISK CONTROLLERS

Add more power to your PC

Page 84

EDITOR'S WORK- BENCH

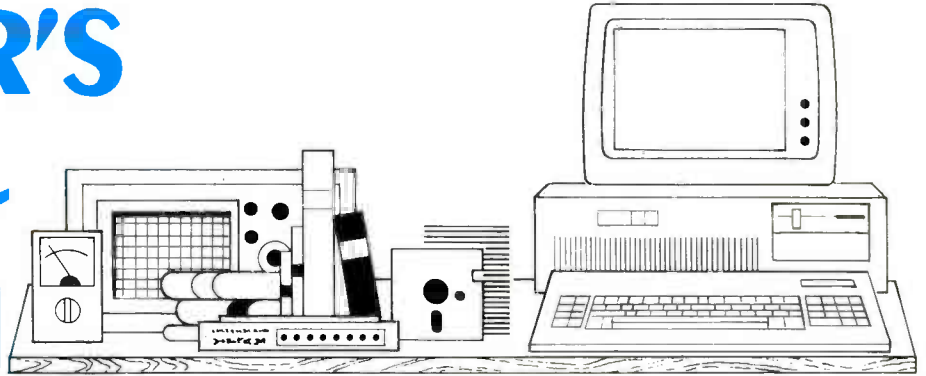

Advanced Floppy-disk Controllers

CP/M brings back fond memories: programs that actually worked in 64K of memory, a sophisticated user community, standard eight-inch disk drives—and hundreds of incompatible 5¼-inch disk formats. The advent of the PC helped resolve those problems for a while; after a few false starts, the IBM PC format meant 360K DSDD disks—period.

Then along came the AT (1.2M at 5¼-inch), then laptops (720K at 3½-inch), followed by PS/2's (1.44M at 3½-inch). We'll refer to those three formats as high-density. And now PC users want to trade files with Macintosh users! The upshot is that we've been thrust back into the quagmire of disk incompatibility.

Is there a way to overcome those incompatibilities? Yes. Many new AT-compatibles and 80386-based machines come with 3½-inch drives. But what about older machines? The BIOS of virtually all older PC's, XT's, and compatibles can't handle the newer formats, and in many cases, the disk controller can handle only two drives; three are necessary to cover all IBM formats.

A simple solution

If your controller handles only two drives, you can remove one and substitute a high-density drive. Recent versions of DOS contain device drivers that you load via CONFIG.SYS in order to read and write the high-density formats. The drivers in DOS 3.30 and higher handle all IBM formats to date.

In addition, some 3½-inch drives are now shipped with equivalent drivers, so you may not need to upgrade your DOS. Check with your supplier to be sure. If you wish to provide Macintosh capabilities using one of the products below (or another), Central Point Software recommends use of Citizen, Teac, and Toshiba drives, and states that some Alps and Mitsubishi drives cannot reliably read Mac disks.

That type of solution still leaves a number of unresolved problems: Macintosh disks, eight-inch disks, combination hard/floppy-disk controllers, copy-protected software, etc. Several companies have designed products that address those problems in a quality manner.

CompatiCard

MicroSolutions has been marketing this floppy-disk controller for several years; it has several advantages over a standard controller. First, it has connectors that allow you to add as many as four disk

drives internally. By contrast, a standard IBM floppy-disk controller allows four drives, but the connector (a 37-pin D type) is only available externally, so adding a third or fourth entails the additional expense of a case and power supply. Also, many clone controllers, and controllers that are part of multi-function cards, have connectors for only two disk drives.

Second, the I/O ports that the PC uses to communicate with the controller are programmable on this card. That allows you to add as many as four cards, for a total of 16 drives in a single PC! You probably won't want to do that, but the addressable I/O ports do have their uses. For example, many combination hard/floppy-disk controllers allow only two floppy-disk drives. You can't just add another standard controller, because it uses the same port addresses, so there would be contention. However, by using a CompatiCard in your PC, you can solve the problem easily.

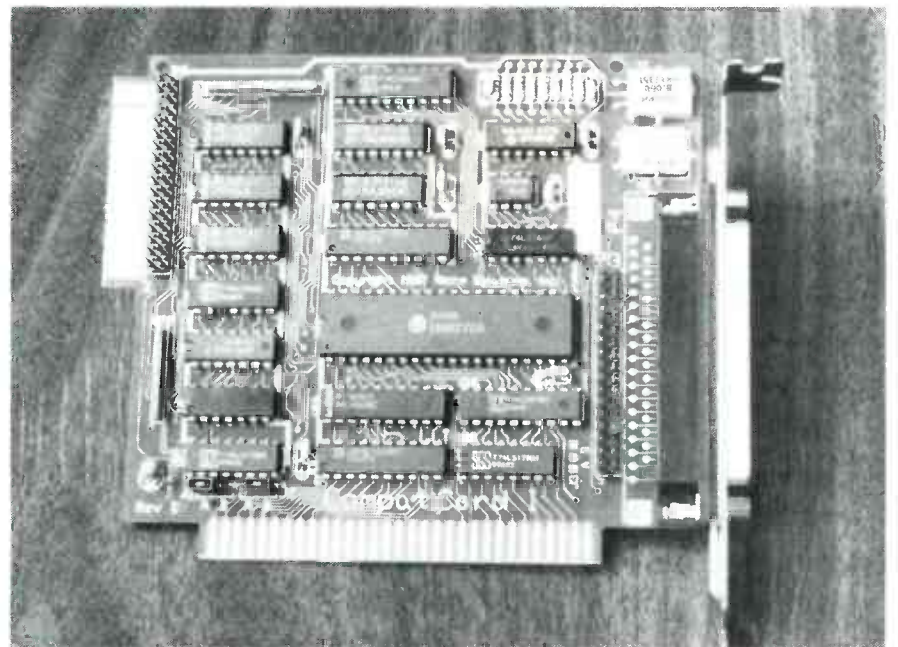

MicroSolutions' CompatiCard.

Third, the card can control eight different types of drives, including all 5¼-inch and 3½-inch drives, as well as 8-inch drives. (A separate software product sold by MicroSolutions, called Uniform, allows you to access CP/M disks in the 8-inch format.) A wiring adapter is required to install an 8-inch drive; you can buy the adapter from MicroSolutions, or build it yourself using information contained in the *User's Guide*. The less expensive CompatiCard II allows only two drives, does not support eight-inch drives, but maintains the many other features of the CompatiCard.

The CompatiCard is a half-length card that installs in any 8-bit slot. Installation consists of setting the jumpers that determine the I/O ports. Then you insert the card into a vacant slot, connect a standard 34-conductor data cable to the card and your drive, connect a power cable to your drive, and then add a line to your CONFIG.SYS file.

Cabling is worth discussion. To add a drive, if your power supply has only a few power connectors, you may need a Y-adaptor to supply power to the drive. You'll also need one 34-conductor data cable for each pair of drives. (Both types of cables are available from JDR, Jameco, or your local computer dealer.) One end of the data cable attaches to the controller card; the CompatiCard has edge-connector and header-pin connectors wired in parallel for the first two drives, and a header-pin connector wired in parallel with an external 37-pin D connector for the last two drives. So a data cable with a header-pin socket will work just fine in either position.

After installing the hardware, you add CCDRIVER.SYS to your CONFIG.SYS file. You add several parameters to that line, depending on the I/O ports the card responds to, the number and type(s) of drive(s) connected to the card, and whether the "twisted" or the "untwisted" connector goes to a particular drive. Several charts in the manual show the correct parameters.

I installed the drive in an AST Premium/286, a 10-MHz 0-wait state AT compatible. Prior to installing the CompatiCard, the machine had both a 5¼-inch, 1.2M drive and a 3½-inch 1.44M drive (Toshiba brand) running off a Western Digital combination hard/floppy controller. I wanted to add a *standard* 360K drive, so I configured the CompatiCard for I/O addresses 360–367h, and added the following line to CONFIG.SYS:

```
DEVICE = C:\SYS\CCDRIVER.SYS /8,0
```

After rebooting, I could access the 360K drive in the normal fashion as drive E. The software driver occupies about 11K of RAM.

The CompatiCard comes with two additional programs. One, CCDRIVES.COM,

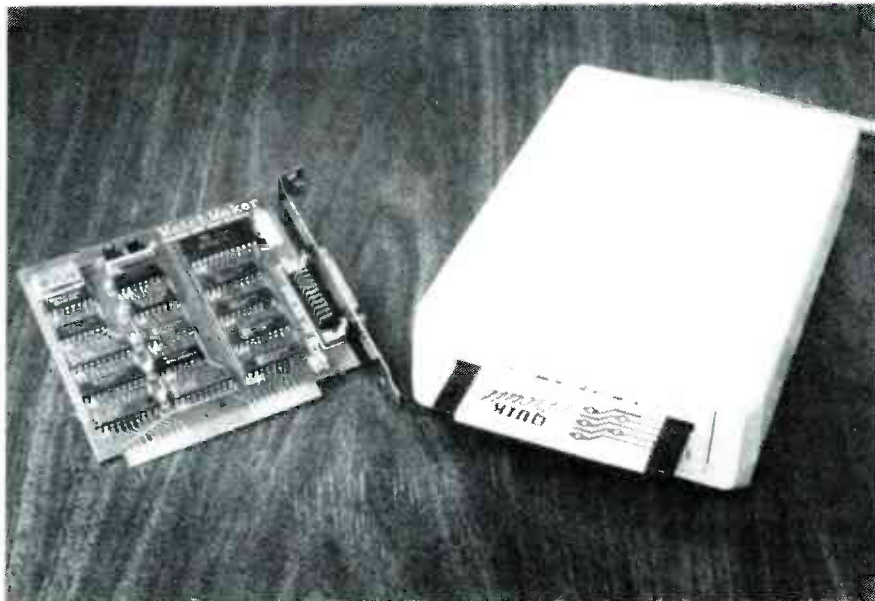

MicroSolutions' MatchMaker.

displays the types of drives attached to the CompatiCard, and indicates the drive letters to use to access those drives. The other, CCFORMAT.COM, may be used instead of the DOS's normal FORMAT program to format disks controlled by the CompatiCard. Technical information is also provided about the extended disk BIOS interrupt services provided by CCDRIVER.SYS.

One thing to watch out for: You can only install a drive as a boot drive if your PC has built-in BIOS support for that drive's format. So don't install a 3½-inch drive as drive A in an old PC, XT, or clone, even if you have a hard disk. The reason is that, if your hard disk flakes out, you won't be able to boot your machine at all.

Also, watch power consumption; a small power supply may not be able to handle three or four drives and a full complement of expansion cards.

MatchMaker

Dealing with IBM disks in various formats is one thing; what about Macintosh disks? MicroSolutions also has a remedy for that problem. The MatchMaker is a half-slot card that can be used to control an external Macintosh disk drive. With supplied memory-resident software, you can address the drive using DOS-like commands preceded by the letter M (MDIR, MCOPY, etc.).

There is little to installing MatchMaker: Just insert the card in an empty eight-bit slot, and plug a Mac drive into the 19-pin D connector. Both data and power are supplied through the single cable. MatchMaker's ports have nothing to do with standard floppy-disk controller ports, so there should be no problem using the card in just about any PC. However, in case you should experience any

hardware conflict with other devices, a pair of jumpers allows you to re-address the card's I/O ports.

Then you run a program called MAC.COM. It remains resident in memory, of which it occupies about 35K, and may be removed later without rebooting. The program allows you to address the Mac drive as drive M (or another letter that you specify) using the following commands: MCD, MCOPY, MDEL, MDIR, MEJECT, MINIT, MMD, MRD, MTREE, and MTYPE. (EJECT forces the disk drive to eject a disk, and INIT formats a disk.)

DOS users will have no trouble adapting to the M commands; with several of them you may specify options. MCOPY, for example, allows you to transfer files to and from Mac diskettes. The command can be used to transfer a single file or a group of files specified using normal DOS wildcards (*and ?). MCOPY options include, among others, copying files to and from either the Mac data or resource (program) fork, creating a locked (write-protected) file, specifying a text or binary file, etc. MDIR options include displaying data, resource, or both forks, an extended directory, etc. MINIT allows you to format disks in either the old (flat) or the new (hierarchical, like DOS) file system, or allow you to format a single-sided diskette in a double-sided drive.

For those unfamiliar with Mac lingo, the manual contains a good discussion of the differences between Mac and IBM disks and file structures.

I installed MatchMaker in the AST machine that I had mentioned before, and had no trouble using the device to read files created on a Macintosh; nor, conversely, did I have trouble reading disks on a Macintosh initialized by MatchMaker.

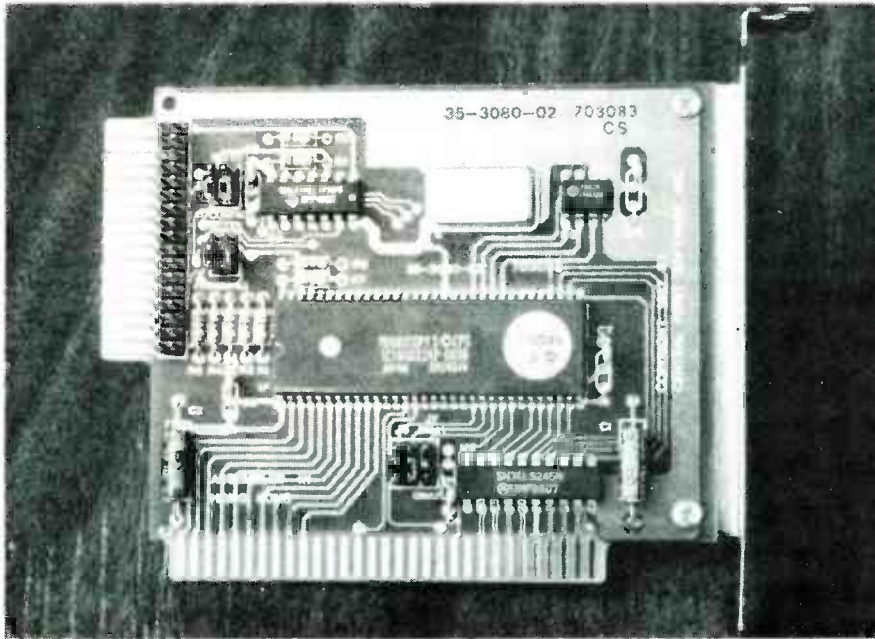

Central Point Software's Deluxe Option Board.

Deluxe Option Board

There are two problems with the preceding solution. First, you must use a Macintosh drive, and second it cannot be mounted internally. Wouldn't it be nice if you could use a regular IBM internal 3½-inch drive?

It turns out that you can, using Central Point Software's Copy II PC Deluxe Option Board. You may have heard of the Option Board in connection with backing up copy-protected software. It still does that; in addition, it allows you to read and write Macintosh-format disks using a 3½-inch disk drive, of either 1.44M or 720K capacity.

Like the other cards discussed here, the Deluxe Option Board is a short card that fits in an eight-bit slot. It can control one or two floppy disks, and has no external 37-pin D connector.

The board has two sets of jumpers. One determines whether the board will be installed in an AT or in a PC (or XT). The other determines the DMA channel to be used; normally you don't need to change it. After setting the jumpers, you insert the board in your computer, and then connect the cables. Electrically, the Option Board sits between your regular floppy-disk controller and your floppy-disk drive(s). The board comes with one cable, but you may end up having to buy another, depending on the length of your present cable. (It may be too short to reach all the way to the Option Board.)

As for software installation, an installation program copies files to your hard disk. The Deluxe Option Board comes with several programs that are used to accomplish different purposes. MCP (Macintosh Control Program) is the program that allows you to read, write and format Mac disks. Assuming that you have

a 3½-inch drive B, to get a directory of a Mac disk in that drive, you'd type:

MCP DIR B:

Other MCP commands include TREE, TYPE, COPY, FORMAT, CD, DC (disk copy), DEL, MD, and RD. Central Point supplies several batch files that reduce the number of keys you must type by invoking MCP with the appropriate parameters. For example, you can use MDIR.BAT to get a directory of a Mac disk in drive B simply by typing:

MDIR B:

A similar batch file is supplied for each MCP command.

As with MatchMaker, some MCP commands have options. MCP COPY, for example, allows for binary, text, and unary file transfers. A binary transfer copies a file (in either direction) byte for byte. A text transfer from Mac to IBM adds line-feeds after carriage return, and strips

them going the other way. A unary transfer from Mac to IBM combines the resource and data forks of a file into a single file, and in the reverse direction, restores the two forks properly.

The Deluxe Option Board also comes with programs for dealing with copy-protected software. TC (Transition Copy) copies not files, not tracks and sectors, not individual bytes of data, but the magnetic fluctuations (transitions) on the surface of one disk to another. The format of the disk is completely irrelevant, as are the locations of hidden files, non-standard sectors, etc. In fact, TC can copy IBM disks, CP/M disks, and even Atari and Apple disks on a standard IBM type disk drive. (Apple and Atari copies are subject to some limitations.) A special version of TC, called TCM, allows you to create an "image" file on hard disk to be used to duplicate disks.

TE is an editor for editing tracks and sectors. Not only can you edit data, you can see the gap and sync bytes that serve to separate one sector from the next. The manual contains an introduction to low-level disk contents, but the treatment is by no means complete.

I installed the Deluxe Option Board in the AST machine, and had no trouble transferring files to and from IBM and Macintosh formats.

Bigger issues

Of course, a big problem, and one that neither Mac/IBM product discussed here addresses, is data-format compatibility. MCOPY in either product can move a file between either type of machine, but what you do with that data is up to you.

Transferring PageMaker and Excel files is easy, because versions of those programs for the two types of machines have compatible data files. But how would you, for example, translate a MacWrite document into WordStar format? Without the aid of a document-conversion utility, you wouldn't. You can transfer straight ASCII text without problem, but formatting information is another story.

The same is true of other types of data; you're on your own and goooooo luck.

Even so, that's not to detract from the real utility of these products, which provide a first step toward greater integration of disparate computer systems.

By the way, by the time I finished writing this review, I had four (!) disk controllers, one hard disk, and three floppy-disk drives in the AST, as well as an external Mac drive, all working harmoniously. First, the Western Digital hard/floppy controller ran the machine's original drives (the 3½-inch 1.44M and the 5¼-inch 1.2M) by way of the Option Board, which also allowed Macintosh access in the 3½-inch drive. Third, the CompatiCard was installed as a secondary controller; it allowed me to

continued on page 96

PRODUCTS DISCUSSED

- **CompatiCard (\$175), CompatiCard II (\$125), MatchMaker (\$149), and external Macintosh disk drive (\$239),** MicroSolutions, 132 W. Lincoln Hwy., Dekalb, IL 60115. (815) 756-3411.
- **Copy II PC Deluxe Option Board (\$159),** Central Point Software, 15220 NW Greenbrier Parkway, Suite 200, Beaverton, OR 97006. (503) 690-8090.
- **Windows/286 2.1 (\$99) and Windows/386 2.1 (\$195),** Microsoft Corporation, 16011 NE 36th Way, Box 97017, Redmond, WA 98073-9717. (206) 882-8080.
- **DOS 4.0 (\$150 or upgrade for \$95) and Windows Kit (\$314),** International Business Machines Corporation. Contact your local IBM dealer for more information.

NEW & IMPROVED!

RS-232

Another serial interface standard?

CHARLES R. BALL, JR.

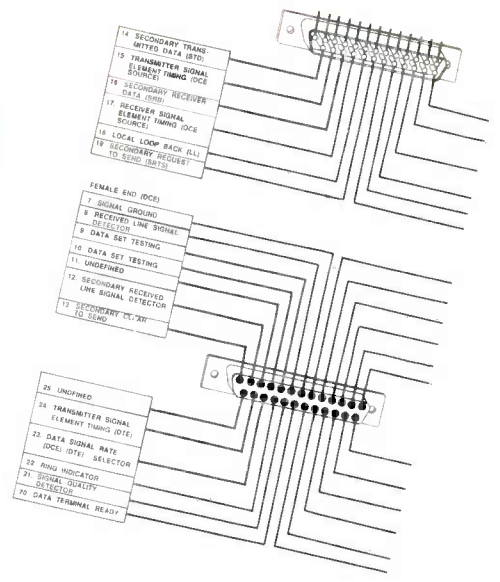

The king is dead! Long live the king! No, we're not talking about Elvis Presley, but a new serial-interfacing standard. The old standard was called RS-232-C, and is currently in wide use on everything from your computer to your CD player.

The new standard is called EIA-232-D, and it differs from the old one primarily in codifying several *de facto* standards, and in defining several new signals that allow for better handshaking and simpler system testing. Let's find out what EIA-232-D is all about.

What, no connector?

A popular misconception is that the RS-232-C standard specifies a computer cable or connector. Actually, it specifies neither; in fact, the specifications hardly even mention cables and connectors. The specifications do, however, specify signal lines—some 22 in all.

Those specifications are contained in a document called *Interface Between Data-Terminal Equipment and Data-Communication Equipment Employing Serial Binary Data Interchange*. (No wonder we call it RS-232!) The standard was first introduced in 1962; it was accepted for use by the Department of Defense as a non-government document in 1969. It was subsequently revised in 1972, and it hasn't been updated since. Rather, creative license has been taken with it to meet up-to-date needs of the computer community.

So, what was originally designed as a serial interface between devices owned by the telephone company (in 1969 all modems belonged to the telephone company), turned out to be a catch-all interface between any two serial devices.

The original

To the dismay of many engineers, the original standard left much to be desired, and for several reasons. First, the original standard did not specify a connector; it merely defined pin numbers. Second, the original standard provided neither true handshaking nor loopback testing. Third, no connector was specified. However, the 25-pin D connector (also known as a DB25) became the *de facto* standard RS-232 connector. A big exception was IBM's introduction of the 9-pin serial-interface connector used with the AT. And, of course, IBM uses the DB25 female connector for its *parallel* printer cable. ARRGH!

How do you spell relief?

The new ANSI/EIA-232-D Standard (available from the EIA for \$20.00; see the sources box) resolves some of the

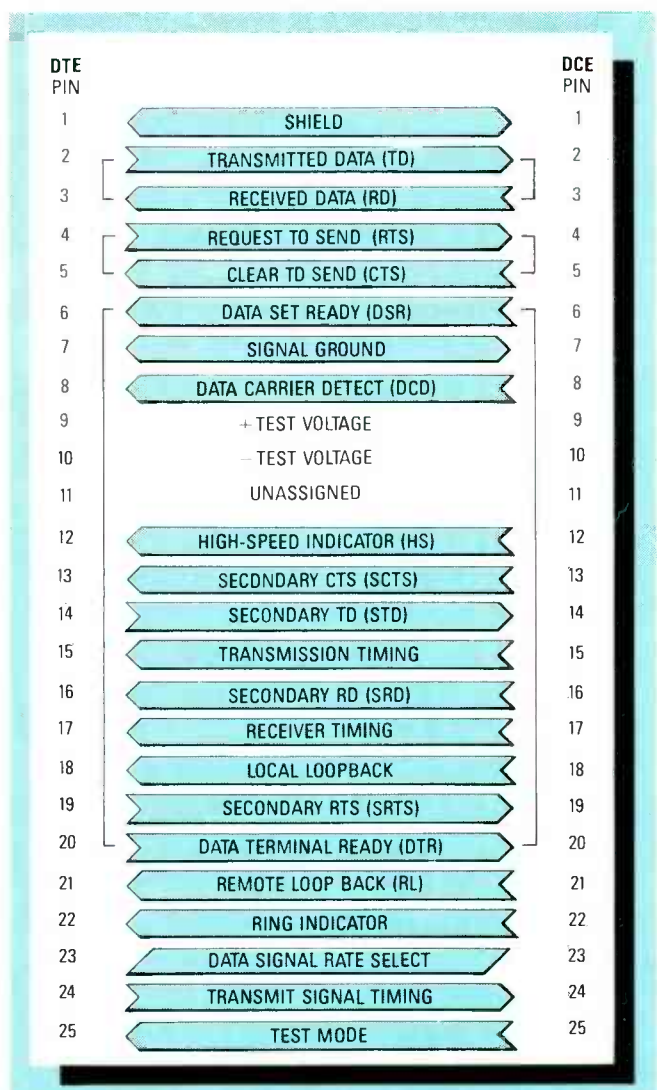

FIG. 1—EIA-232-D SIGNALS are defined here, along with signal directions. A DTE is usually an originating device (such as a serial terminal); a DCE is usually a receiving device (a modem or printer, for example).

problems. Table 1 summarizes the primary EIA-232-D specifications; in addition, the new standard defines the DB25 as the standard connector. That's just great, because it's the one that most of us use anyway.

In the new system, signal functions are now defined to facilitate fully interlocked data handshake between Data-Terminal Equipment (DTE) and Data-Communications Equipment (DCE). DTE generally includes serial terminals, and DCE generally includes printers and modems. However, that's not an ironclad rule.

By definition, a device that transmits on pin 2 is DTE; a device that transmits on pin 3 is DCE. DTE's are usually male connectors, and DCE's are usually female connectors. Figure 1 shows the signal name and direction of each pin in both DCE and DTE.

TABLE 1—EIA-232-D SPECIFICATIONS

Parameter	Specification
Connector, DTE	DB-25 Male
Connector, DCE	DB-25 Female
Maximum Cable Length	Limited by capacitance (2500pF max.)
Maximum Data Rate	20K bits/sec
Number of drivers and receivers on line	1 driver 1 receiver
Driver Output Swing	±5V min.; ±15V max.
Driver Load	3K to 7K ohms
Driver Slew Rate	30V/μS max.
Receiver Input Resistance	3K to 7K ohms
Receiver Input Threshold	±3V
Receiver Input Range	±30V max.

Devices with the same characteristics (i.e., two DTE's or two DCE's) can be connected by reversing several pairs of conductors. For example, to connect two DTE's, you

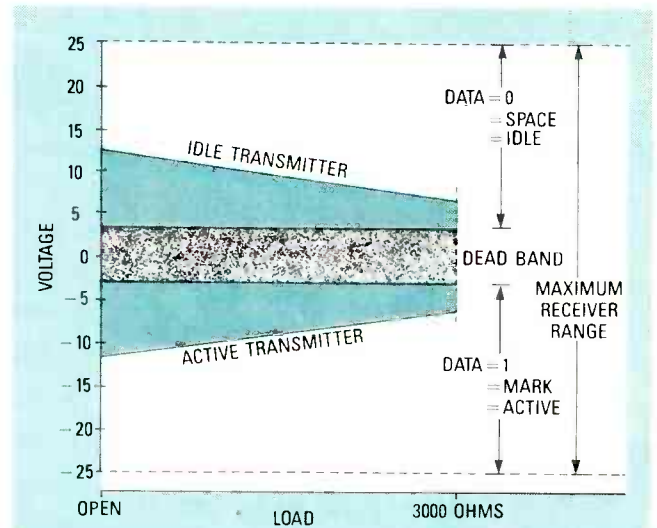

FIG. 2—EIA-232-D SIGNAL LEVELS are shown here. A ±12-volt swing is suitable for loads of as much as 3000 ohms.

might swap pins 2 and 3, pins 4 and 5, and pins 6 and 20. A cable (or adapter) that implements that type of connection is called a null-modem cable (or adapter). In some cases only pins 2 and 3 need be swapped; in others, half a dozen or more may need to be swapped. The type of equipment and the software controlling it are the determining factors.

New lines

Three new signals have been created by defining previously undefined lines or redefining existing signal lines. Table 2 shows the old and new pin definitions. Note that pin 21 is now called remote loopback (RL); it is used to enable remote-loopback testing. The basic idea of loop-

TABLE 2—RS-232 VS. EIA-232

Pin	RS-232		EIA-232	
	Circuit	Description	Circuit	Description
1	AA	Protective Ground	—	Shield
2	BA	Transmitted Data	BA	Transmitted Data
3	BB	Received Data	BB	Received Data
4	CA	Request to Send	CA	Request to Send
5	CB	Clear to Send	CB	Clear to Send
6	CC	Data Set Ready	CC	DCE READY
7	AB	Signal Ground	AB	Signal Ground
8	CF	Received Line Sig. Det.	CF	Received Line
9	—	Reserved for Testing	—	Reserved for Testing
10	—	Reserved for Testing	—	Reserved for Testing
11	—	Unassigned	—	Unassigned
12	SCF	Sec. Rec'd Line Sig. Det.	SCF/CI	Sec. Rec'd Line Sig. Det/ Data Signal Rate Select
13	SCB	Sec. Clear to Send	SCB	Sec. Clear to Send
14	SBA	Sec. Transmitted Data	SBA	Sec. Transmitted Data
15	DB	Trans. Sig. Element Timing	DB	Trans Sig. Element Timing
16	SBB	Sec. Received Data	SBB	Sec. Received Data
18	—	Unassigned	LL	Local Loopback
19	SCA	Sec. Request to Send	SCA	Sec. Request to Send
20	CD	Data Terminal Ready	CD	Data Terminal Ready
21	CG	Sig. Quality Detector	RL/CG	Remote Loopback/Sig. Quality Detector
22	CE	Ring Indicator	CE	Ring Indicator
23	CH/CI	Data Sig. Rate Detector	CH/CI	Data Signal Rate
24	DA	Trans. Sig. Element Timing	DA	Trans. Sig. Element Timing
25	—	Unassigned	TM	Test Mode

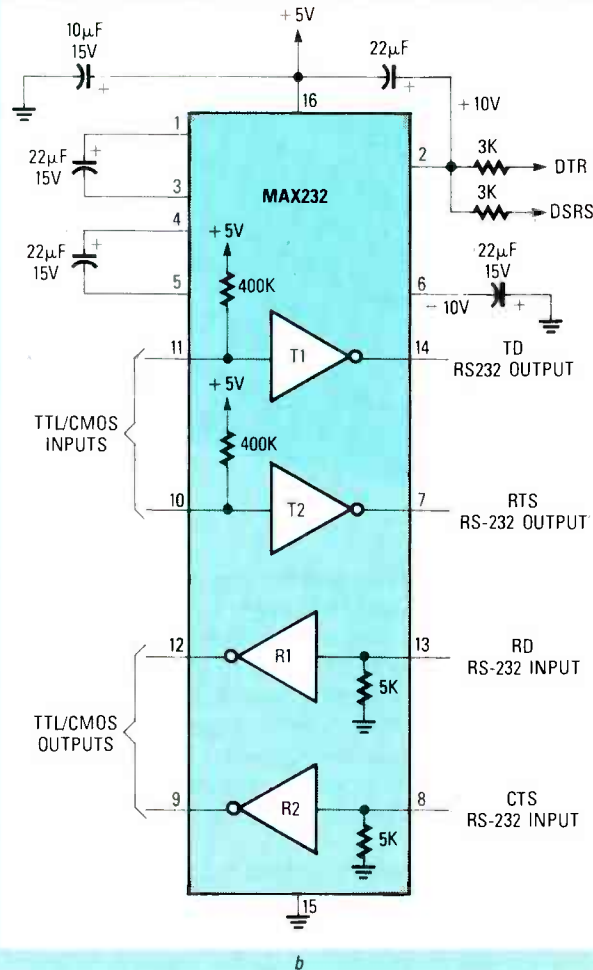
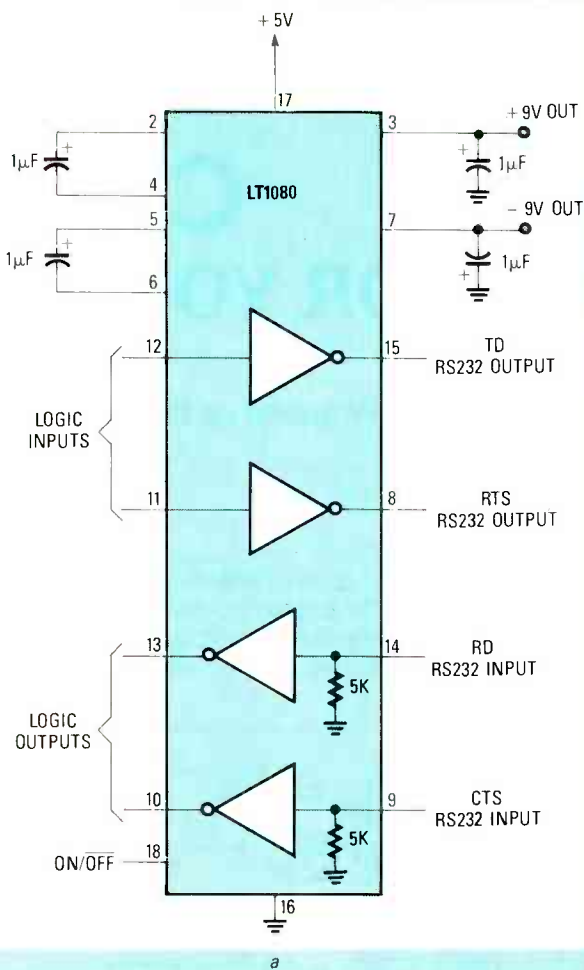

FIG. 3—THE LT1080 (a) AND THE MAX232 (b) can swing RS-232 voltages with only a +5-volt supply.

back testing is as follows: A device transmits a signal and reads it back in. If there is any discrepancy between the two, there is a problem with the communications circuit or one of the devices in the circuit.

Actually, there are two types of loopback: local and remote. A local loopback test may be as simple as shorting transmit and receive pins and initiating a test program. In a remote test, data is transmitted through some sort of circuit, through an answering device, and then back through the circuit to the originating device. A modem engaged in remote-loopback testing, for example, might send test signals over a telephone line to another modem, which would then echo those signals back to the first modem.

A DTE uses the RL signal to tell a DCE to loop back, thereby enabling the DTE to test the integrity of the communications connection between the two devices. Similarly, previously undefined pin 18 is now called local loopback (LL).

Last, previously undefined pin 25 is now called test mode (TM); the DCE uses it to inform the DTE that it has received an RL or LL signal from the DTE.

Signal levels

It's common to use ± 12 -volt signal swings in RS-232 circuits. You may have wondered why anyone would

specify a computer interface requiring a ± 12 -volt supply, especially when everyone knows that most digital equipment runs on +5 volts. The answer to that question probably has to do with the popularity of those voltages (which were often used in analog circuits) at the time the RS-232-C standard was drafted.

Figure 2 shows the signal levels defined in the new standard. Note that the basic range is ± 3 – ± 25 volts DC.

The idle state of an EIA-232-D interface is high, also called space. During a data transmission, that state corresponds to a binary 0. The active state is called mark or binary 1. Anything in between (in the range between +3 and -3 volts) is called the dead band; signals in that range are undefined.

For short-range transmission, you can get away with a ± 5 -volt supply, but with much loading, errors would be likely. To attain maximum range, you'd want to use ± 25 -volt supplies. A ± 12 -volt supply is commonly used because it strikes a good balance between range and circuit cost. Also, the ubiquitous 1488 and 1489 line driver and receiver IC's operate at those voltages.

Potential problems

One perennial problem with serial interfaces is signal voltages. How do we get ± 12 volts from digital circuits that operate from +5-volt supplies? Couldn't the standard be changed to accommodate +5-volt signals?

continued on page 95

PART III

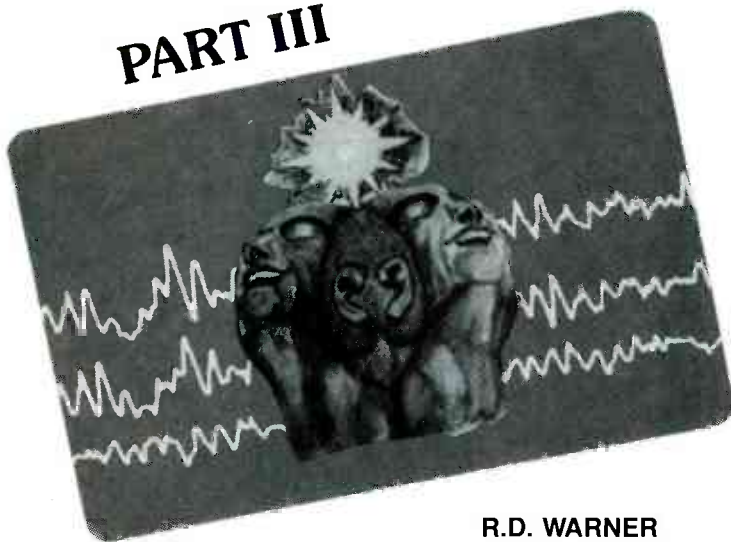

R.D. WARNER

BUILD A SYNERGY CARD FOR YOUR PC

Wrapping up the Synergy Card

This is the last of three articles discussing the theory, construction, and use of a Synergy Card, a device used for generating sound effects and influencing brain function. In Part 1 we discussed the theory of a technique that uses audio signals to influence brain function. The goal of that technique is to achieve *Hemisphere Synchronization* (HS) by means of *Frequency-Following Response* (FFR). It is theorized that hemisphere synchronization creates a mental atmosphere that allows for better concentration and more creativity.

In the second part we described the circuitry of a card that plugs into any IBM PC compatible, and allows you to experiment with HS, FFR, and to generate sound effects and multi-voice music. The card also has a number of digital I/O lines that can interface your PC to bio-monitoring or to other equipment.

This time, we'll show you how to build, test and operate the Synergy Card. Included are software listings in BASIC, assembler, and DEBUG scripts. Those programs may be used as-is for testing purposes, or may be used as models and expanded for more-complex usage. All listings are also available on RE-BBS (516-293-2283, 300/1200 baud, 8 data bits, no parity, 1 stop bit); just download the file HEMISYNC.ARC.

If you build your own card, you'll have to deal with the absence of plated-through holes. That means that you'll have to solder many components on both sides of the board, install feed-throughs, etc. If you choose that method, be very careful, and check your work several times.

Use the parts-placement diagram shown in Fig. 3 to mount all components. Note that the IC's are installed in various orientations, so double-check to make sure that none is installed backward.

Regardless of construction method, when you're ready to stuff the board, first install all decoupling capacitors (C13-C18, with C16 mounted on the solder side), and C19 and C20. When you install C19, note its proximity to trimmer resistor R12. Now connect a DMM across V_{CC} and ground to check for shorts.

Now do the audio section, mounting R14 and R15 on the solder side of the board. Some of the discrete components are very close together, so be careful and check your work several times.

Next, install J1, J2, and the mounting bracket. The mounting tabs of the bracket go on the component side of the board. There should be enough play in the mounting holes so the bracket lines up with the connectors; if

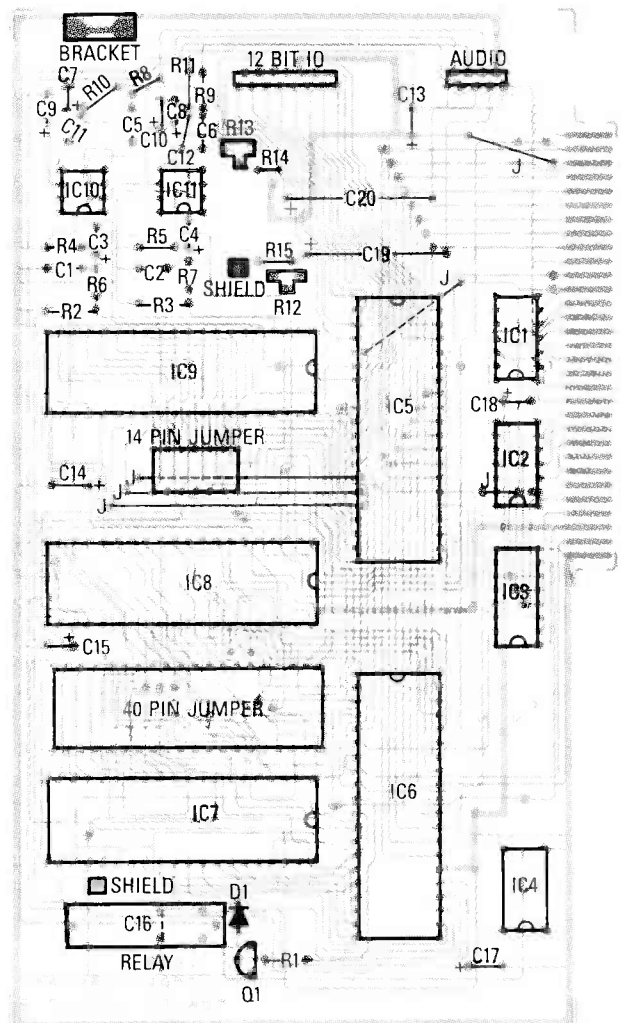

FIG. 1—MOUNT ALL COMPONENTS as shown here, being careful in the audio section, where close component mounting could lead to shorts.

TABLE 1—LOGIC LEVELS

Pin	PSG		PPI	
	Before	After	Before	After
1	LOW		VAR, HI-Z	LOW
2	N.C.		VAR, HI-Z	LOW
3	LOW		VAR, HI-Z	LOW
4	LOW		VAR, HI-Z	LOW
5	N.C.		PULSE	
6	HIGH		HIGH	
7	HIGH		LOW	
8	HIGH		PULSE	
9	HIGH		PULSE	
10	HIGH		LOW, HI-Z	LOW
11	HIGH		HI-Z	LOW
12	HIGH		HI-Z	LOW
13	HIGH		HI-Z	LOW
14	HIGH		HI-Z	LOW
15	HIGH		HI-Z	LOW
16	HIGH		HI-Z	LOW
17	HIGH		HI-Z	LOW
18	HIGH		VAR	LOW
19	HIGH		VAR	LOW
20	HIGH		VAR	LOW
21	HIGH		VAR	LOW
22	PULSE		VAR	LOW
23	HIGH		VAR	LOW
24	LOW		VAR	LOW
25	HIGH		VAR	LOW
26	VARIABLES		HIGH	
27	HI-Z	LOW	PULSE	
28	HI-Z	LOW	PULSE	
29	HI-Z	LOW	PULSE	
30	VARIABLES	LOW	PULSE	
31	VARIABLES	LOW	PULSE	
32	VARIABLES	LOW	PULSE	
33	VARIABLES	LOW	PULSE	
34	VARIABLES	LOW	PULSE	
35	VARIABLES	LOW	LOW	
36	VARIABLES	LOW	PULSE	
37	VARIABLES	LOW	VAR, HI-Z	LOW
38	LOW		VAR, HI-Z	LOW
39	VAR		VAR, HI-Z	LOW
40	HIGH		VAR, HI-Z	LOW

not, you can drill the mounting holes out slightly. Don't drill them too much, though, or you'll damage the traces. The card was designed using a bracket supplied by Vector; others may not align correctly. Install the 40- and 14-pin jumper header sockets, and then all wire jumpers.

Let's do a little more checking before continuing. Again, make sure that V_{CC} and ground are not shorted. The forward-biased resistance across a decoupling capacitor should be around 35 ohms. Also, make sure that none of the edge-card fingers is shorted to a neighbor. Correct any problems before proceeding.

Then wire up an audio cable that connects J2 to the appropriate inputs of your stereo system. The LM386's can drive headphones directly; doing so may be most convenient for testing.

With the computer turned off, insert the card in a slot, and connect the card to the Tape or Aux. jacks of your stereo. Make sure the card is aligned in the slot properly. Then turn your stereo on with the volume low. Now turn the computer on and apply an audio signal to the junction of R2 and R6. You should hear the tone through the left speaker. Then apply the tone to the junction of R3 and R7: This time you should hear the tone over the right speaker.

Remove the card from your PC (after powering it down, of course), and correct any problems. Then solder in the

clock (IC4), Q1, R1, and RY1. The clock has a dot on one end that indicates pin 1. A transistor with in-line pins (not pin-circle) should be used for Q1. Otherwise, the collector and emitter will be reversed. Now mount IC1, IC2, and IC3, followed by IC5 and IC6.

Testing

After resolving any problems, install the card in your PC and boot up. Then use a logic probe to check the pins of the Programmable Peripheral Interfaces (PPI's) and the Programmable Sound Generators (PSG's). Your readings should match those in Table 1. The "Before" and "After" columns in that table refer to the states of the respective pins before and after the initialization program is run.

Here are a few notes on why various readings are obtained. Before initialization, PPI I/O ports are in a high-impedance state. So, for example, Port A of PPI1 (IC5, pins

LISTING 1

```

C>debug                               ;Enter Debug
-A                                     ;Go into assemble mode

XXXX:0100 MOV    BX,D000               ;Set segment to D000,
XXXX:0103 MOV    DS,BX                 ; which is card location.
XXXX:0105 MOV    DI,FFFB
XXXX:0108 MOV    BH,80                 ;Set PPI ports to OUTPUT -
XXXX:010A MOV    [DI+03],BH            ; first PPI 0.
XXXX:010D MOV    [DI+07],BH            ; then PPI 1.
XXXX:0110 MOV    [DI+02],BL            ;Write zero to all ports, the
XXXX:0112 MOV    [DI+01],BL            ; PSG control reg's first so
XXXX:0115 MOV    [DI],BL               ; that PSG's are in INACT state.
XXXX:0118 MOV    [DI+06],BL
XXXX:011B MOV    [DI+05],BL
XXXX:012E MOV    [DI+04],BL
XXXX:0123 INT    20                    ;Return to DOS
-RBX                                   ;Hit return to quit assembly
BX 0000                                ;Make register BX set to zero
:O
-RCX
CX 0000                                ;Set CX to program length
:23                                    ; in hex bytes
-N B:SCINIT.COM                       ;Give the program a COM name
-W                                     ;Write it to disk
Writing 0023 bytes
-Q                                     ;Quit
C>
    
```

LISTING 2

```

10 DEF SEG = &H5000                   'This loads the
                                     procedure
20 FOR I = 256! TO 535!                ' outside of BASIC -
30 READ IMBED%                         ' set 10 to where you
                                     like
40 POKE I,IMBED%                       ' but leave offset
                                     alone.
50 NEXT I
55 '-----
60 DATA &H50,&H53,&H51,&H52,&H1E
70 DATA &H57,&H56,&H88,&H00,&HDD,&H8E,&HDB,&H87,&H80,&H8F,&H8B
75 DATA &HFF,&H88,&H3D,&H8F,&HFF,&HFF,&H88,&H3D,&H32,&HFF,&H8F
80 DATA &HFA,&HFF,&H88,&H3D,&H8F,&H8F,&H88,&H3D,&H8B,&H06
90 DATA &H90,&H00,&H01,&H00,&H00,&H00,&H2E,&H88,&H1E,&H2A,&H01
100 DATA &H80,&HFF,&H30,&H7C,&H2D,&H80,&H80,&HFF,&H30,&H74,&H08,&H80
110 DATA &HFF,&H31,&H74,&H13,&H89,&HCD,&H00,&H2E,&H06,&H06,&H29
115 DATA &H01,&H80,&H8F,&HFA,&HFF,&H83,&H80,&H88,&H1D,&H89,&H8D
120 DATA &H00,&H2E,&H06,&H06,&H29,&H01,&H00,&H8F,&HFA,&HFF,&H32
125 DATA &HDB,&H88,&H1D,&H89,&HAD,&H00,&H80,&H80,&HFF,&H20,&H7C,&H09
130 DATA &H80,&H8F,&H20,&H8F,&H02,&H00,&H8B,&H11,&H90,&H80,&H80
140 DATA &H10,&H7C,&H09,&H80,&H8F,&H10,&H8B,&H01,&H80,&H8B,&H03
150 DATA &H90,&H33,&HFF,&H53,&H83,&HFF,&H02,&H7C,&H60,&H8F,&HFD
155 DATA &HFF,&H8E,&HFE,&HFF,&H59,&H2E,&H8A,&H3E,&H29,&H01,&H8D
160 DATA &HFF,&H80,&H74,&H06,&H33,&H8D,&H53,&H8B,&H04,&H90,&H32
170 DATA &HDB,&H53,&H2E,&H8A,&H16,&H28,&H01,&H8B,&H06,&H00,&HFF
180 DATA &H2E,&H2E,&H02,&H06,&H27,&H01,&H50,&H52,&H2E,&H06,&H27
185 DATA &H28,&H01,&H8B,&H07,&H00,&HFF,&H2E,&H2E,&H02,&H06,&H27
190 DATA &H3C,&H8A,&H8D,&H88,&H3D,&H8A,&H8D,&H88,&H1C,&H5B,&H88
200 DATA &H83,&H01,&H2E,&H88,&H1E,&H88,&H1E,&H32,&HDB,&H2E,&H88
210 DATA &H1E,&H27,&H01,&H8B,&H2A,&H90,&H8E,&HFA,&HFF,&H2E,&H8A
220 DATA &H1E,&H29,&H01,&H80,&H8F,&H80,&H75,&H05,&H2E,&H88,&H1E
235 DATA &H27,&H01,&H83,&HFF,&H00,&H7F,&H0C,&H83,&H10,&H2E,&H88
240 DATA &H1E,&H28,&H01,&H8F,&H8F,&HFF,&H8B,&H83,&H8F,&H8F,&H8F
245 DATA &H89,&H7D,&HFF,&H5E,&H5F,&H1F,&H5A,&H59,&H5B,&H58,&HCB
248
250 INPUT "ENTER REGISTER NUMBER";R1%
260 IF R1% = 99 THEN GOTO 330          'Enter "99" to exit
prog
270 INPUT "ENTER DATA TO WRITE";D1%
280 POKE 298!,D1%                      'Set segment to match
290 POKE 299!,R1%                      ' line 10, but offset
300 OFFST= 256!                         ' must equal 256 or
310 DEF SEG = &H5000                   ' hex 100.
315 CALL OFFST
320 GOTO 250
330 END
    
```

LISTING 3

```

XXXX:0100 MOV    BX,D000    ;Set segment to D000,
XXXX:0103 MOV    DS,BX     ; which is card location.
XXXX:0105 MOV    DI,FFFB
XXXX:0108 MOV    BH,80     ;Set PPI ports to OUTPUT -
XXXX:010A MOV    [DI+03],BH ; first PPI 0.
XXXX:010D MOV    [DI+07],BH ; then PPI 1.
XXXX:0110 MOV    [DI+02],BL ;Write zero to non-I/O ports, the
XXXX:0112 MOV    [DI+01],BL ; PSG control reg's first so
XXXX:0115 MOV    [DI],BL   ; that PSG's are in INACT state.
XXXX:0118 MOV    AX,F0FF   ;AH sends INACT to PSG 2, and
XXXX:011B MOV    [DI+06],AH ; makes 4 I/O bits HIGH.
XXXX:011E MOV    [DI+05],BL ;Writes zero to PSG 2 data lines
XXXX:0121 MOV    [DI+04],AL ;AL makes 8 I/O bits go HIGH
XXXX:0124 INT    20       ;Return to DOS
    
```

1-4 and 37-40) should show a high impedance on your logic probe before running the initialization program. Port A of the other PPI behaves the same way.

The B ports (pins 18-25) of both PPI's show varied readings, because they're connected to the data lines of the PSG's, and a PSG does disconcerting but harmless things unless the INACT (inactive) command (000) is present on its control lines (pins 27-29). PSG pins 6-21 are for the two I/O ports, and appear high when in the input mode.

Now let's discuss the initialization program, SCIN-IT.COM, shown in Listing 1. What it does is to set all PPI ports to outputs, and then loads a zero into each one, driving all port lines low. The lows on the control lines of the PSG's constitute the INACT command, so the PSG's calm down. PSG pins 26 and 39 will still vary, because they are test pins whose function varies depending on which model of the AY-3-8910 IC you have.

Now load and run SCINIT.COM using DEBUG. Enter the assembly-language instructions and debug commands as shown, but don't enter the semicolons or the comments following them. Ignore the X's shown in the first column. After running the program, you'll notice that the data and control lines of the PSG's are now all low.

That initialization program tests the steering logic, but to really check the individual data and I/O lines requires the use of a larger assembly-language procedure, which, unfortunately, we don't have enough space to publish. You can however, download it from the RE-BBS. If you assemble the program, make sure that the last byte in the object file generated is 0CBh. The author found that when using his macro assembler, it is necessary to go in manually and change that byte; otherwise he couldn't get the procedure to return properly to the BASIC program shown next. The last line of the source code may be a dummy, because no matter what's put in there, it doesn't compile right. For some reason, it insists on executing an intra-segment return (0C3h), instead of an inter-segment return.

The assembly-language procedure is also embedded in the BASIC program shown in Listing 2. That program allows you to write any byte-size value to any one of the Synergy Card's 50 registers. Remember, each PSG has 16 registers; registers 0-47 are used to set and reset the PSG lines, and registers 48 and 49 are dummies used to turn the relay on and off (which in turn is used to control the motor of a cassette recorder).

For example, if you write a 2 to any of the registers 32-47, line D1 of PSG2 will go high. Or by writing a 1 to any of the registers 16-31, D0 of PSG1 will go high.

By forcing one bit high at a time, you can thereby check not only the PSG's, but the PPI's as well. If a PSG line doesn't go high, check the corresponding PPI line. If it

TABLE 2—MUSICAL NOTES

Note	Octave	Ideal	Note	Octave	Ideal
C	1	32.703	C	5	523.248
C#	1	34.648	C#	5	554.368
D	1	36.708	D	5	587.328
D#	1	38.891	D#	5	622.256
E	1	41.203	E	5	659.248
F	1	43.654	F	5	698.464
F#	1	46.249	F#	5	730.984
G	1	48.999	G	5	783.984
G#	1	51.913	G#	5	830.608
A	1	55.000	A	5	880.000
A#	1	58.270	A#	5	932.320
B	1	61.735	B	5	987.760
C	2	65.406	C	6	1046.496
C#	2	69.296	C#	6	1108.736
D	2	73.416	D	6	1174.656
D#	2	77.782	D#	6	1244.512
E	2	82.406	E	6	1318.496
F	2	87.308	F	6	1396.928
F#	2	92.498	F#	6	1479.968
G	2	97.998	G	6	1567.968
G#	2	103.826	G#	6	1661.216
A	2	110.000	A	6	1760.000
A#	2	116.540	A#	6	1864.640
B	2	123.470	B	6	1975.520
C	3	130.812	C	7	2092.992
C#	3	138.592	C#	7	2217.472
D	3	146.832	D	7	2349.312
D#	3	155.564	D#	7	2489.024
E	3	164.812	E	7	2636.992
F	3	174.616	F	7	2793.856
F#	3	184.996	F#	7	2959.936
G	3	195.996	G	7	3135.936
G#	3	207.652	G#	7	3322.432
A	3	220.000	A	7	3520.000
A#	3	233.080	A#	7	3729.280
B	3	246.940	B	7	3951.040
C	4	261.624	C	8	4185.984
C#	4	277.184	C#	8	4434.944
D	4	293.664	D	8	4698.624
D#	4	311.128	D#	8	4978.048
E	4	329.624	E	8	5273.984
F	4	349.232	F	8	5587.712
F#	4	369.992	F#	8	5919.872
G	4	391.992	G	8	6271.872
G#	4	415.304	G#	8	6644.864
A	4	440.000	A	8	7040.000
A#	4	466.160	A#	8	7458.560
B	4	493.880	B	8	7902.080

went high, there's probably an open somewhere between the two. It doesn't take long to go through and check each line that way, and it can save a lot of headaches later.

You can also test the relay using that program: If you write to register 48, the relay will close, and if you write to register 49 it will open. It doesn't matter what data you write to the dummy registers.

How do you test the PSG I/O lines? You can use the same routine, because the I/O registers are accessed just like the fourteen sound-control registers. Remember that register 7 of each PSG controls the data direction of its two I/O ports, using bits 6 and 7 (for ports A and B, respectively). When one of those bits is high, the corresponding port is an output port, and when it's low, the port is an input port.

So, to test the output ports first you must write a decimal 192 to registers 7, 23, and 39. Then, once again, simply make each bit go high one at a time. For example, by writing 192 to register 39, and then 128 to register 47, bit B7 (the second port) of PSG2 will go high.

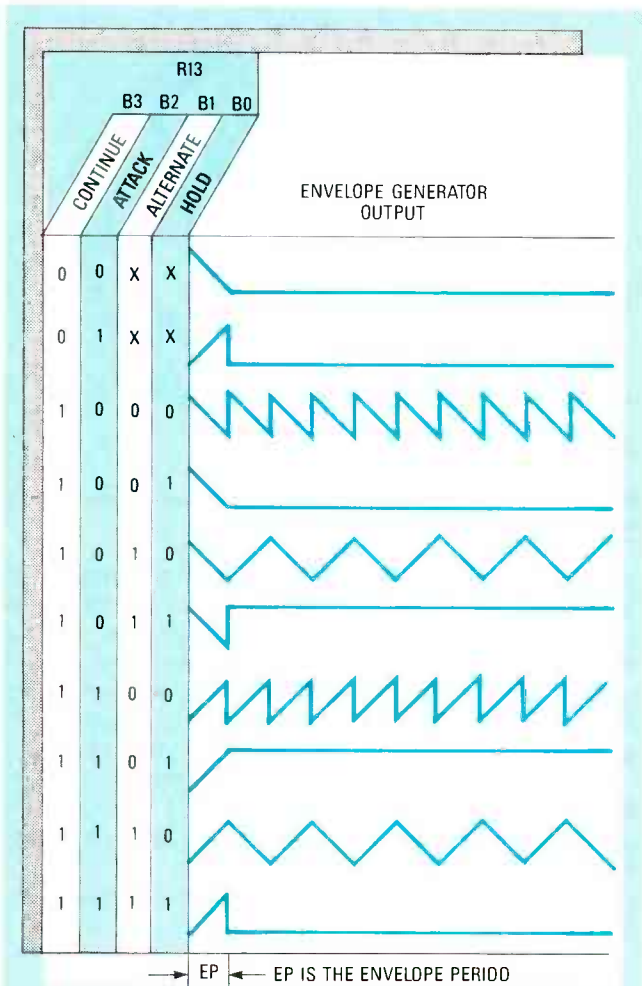

FIG. 2—THE CONTENTS OF PSG REGISTER 13 determines the shape of the envelope.

To test the twelve bits of I/O coming straight from IC5, you need to use a procedure similar to that used in SCINIT.COM. Remember that Port A and the top 4 bits of Port C supply that I/O, so all you have to do is set the PPI to output mode, and then write to the ports. Listing 3 shows a DEBUG procedure that will set all 12 bits high.

That completes the digital testing. Track down and correct any problems before proceeding.

Make beautiful (?) music

Install the Synergy Card in your PC, and connect it to your audio system as described last time. Turn on the computer and make sure that it boots. Then turn on the audio system with the volume low, and run the initialization program.

To begin, let's make a single layer (one tone pair) of Synergistic Sound. Since one tone will go to each channel, write to PSG1. In it, voices A and B go to the left channel, and C goes to the right. (That way we only have to enable the tones in one PSG.) To enable A and C, and disable noise in all three channels, write a decimal 58 to register 23.

Next write the appropriate values into the coarse- and fine-tune registers to get the desired frequency. For this example we'll create tones of 200 and 202 Hz, which provide a synergistic sound frequency of 2 Hz, a nice delta brain-wave frequency.

PARTS LIST

All resistors are 1/4-watt, 5% unless otherwise noted.

- R1-R3—1000 Ohms
- R4, R5—500 Ohms
- R6, R7—68,000 Ohms
- R8, R9—15,000 Ohms
- R10, R11—10 Ohms
- R12, R13—10,000 Ohms Trimmer Potentiometer
- R14, R15—27,000 Ohms

Capacitors

- C1, C2—330 pF, mica
- C3, C4—2.2 μ F, 15 volts, tantalum
- C5, C6—0.01 μ F, ceramic disc
- C7, C8—10 μ F, 15 volts, tantalum
- C9, C10—0.1 μ F, 15 volts, tantalum
- C11, C12—0.047 μ F, ceramic disc
- C13—22 μ F, 15 volts, tantalum
- C14-C18—0.1 μ F, 15 volts, tantalum
- C19, C20—220 μ F, axial, 15 volts, electrolytic

Semiconductors

- IC1—74LS30N, 8-input NAND gate
- IC2—74LS10P, triple 3-input NAND gate
- IC3—74LS138, 3-to-8 decoder
- IC4—1.8432-MHz, clock
- IC5, IC6—8255A-5, programmable peripheral interface
- IC7-IC9—AY-3-8910A, programmable sound generator
- IC10, IC11—LM386N-1, audio amplifier
- Q1—2N3904, NPN transistor

Other components

- J1—9-pin "D" connector, PC mount
- J2—15-pin "D" connector, PC mount
- RY1—5-volt SPST reed relay (Radio Shack)

Miscellaneous

- Metalized hood for 9- and 15-pin connectors.
- Shielded plugs and cables for stereo hookup.
- $\frac{3}{32}$ " plug for cassette remote jack.

Note: The following are available from Perceptual Research Ventures, P.O. Box 20151, Missoula, MT 59801: Etched, drilled, tin-plated, and silk-screened PC board (PR-10), \$36.00; assembled, tested, and coated card (PR-48), \$319.95; custom cabling (PR-8), \$28.95; Sleep Lab software, compiled, runs card as a background task, leaving CPU free for other work, (PR-100), \$25. Unfortunately, due to FCC regulations, the assembled and tested unit may be sold only to qualified research institutions. All orders add \$5 for postage and handling.

We calculated the register values for the 200-Hz carrier frequency last month: CT = 2, and FT = 64. Using the same technique for 202 Hz, we get CT = 2, and FT = 58. Working backward, those values will actually yield a frequency of 202.1053 Hz (assuming the clock frequency is exact). If FT were 59, we would get a frequency of 201.7513 Hz, so the first value yields the most accurate results.

To generate those tones, write a 64 to register 16, 2 to register 17, 58 to register 20, and 2 to register 21. Now just turn up the volume. Increase the on-board volume to maximum by writing a 15 to register 24 and register 26. Writing a 16 to those registers would switch from fixed-amplitude to envelope.

Table 2 shows the ideal frequency for eight octaves of notes ranging from C1 to B8. You'll find that the card is capable of getting within 0.01 Hz of the ideal frequency for low notes, and within about 88.0 Hz at the upper end, due to nonlinear distribution.

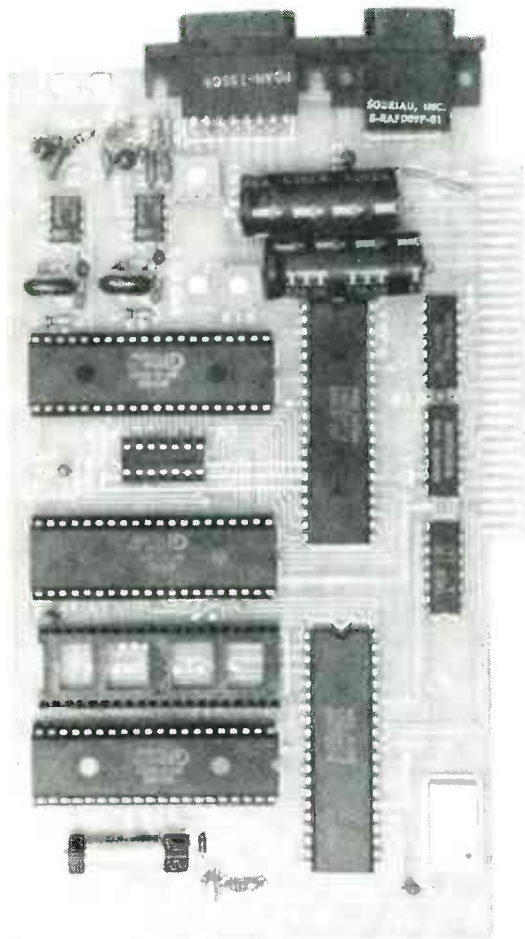

FIG. 3—THE COMPLETED BOARD. Note that IC sockets are used for IC7–IC9, and for the jumper headers. The jumper headers, if desired, can provide 48 bits of I/O in addition to the 12 bits available at J2.

Now let's see how to use amplitude envelopes and noise generators. This demonstration provides a mix that sounds like ocean surf. You can turn off the previous tones by writing a 0 to registers 24 and 26.

Our surf will use a logarithmic, U-shaped envelope of white noise. A 0.10-Hz signal goes to the left channel, and 0.12 Hz to the right. The frequency difference means the phase relationship will change constantly, making the sound realistic.

The first thing we need to do is calculate our coarse- and fine-tune register values for the envelopes. The equation is almost identical to that used for tones, and can be solved in the same way:

$$f_{EN} = f_{CL} / [256 \times (256CT + FT)]$$

In that equation, f_{EN} represents the desired envelope frequency, CT and FT represent the coarse- and fine-tune registers, and f_{CL} represents the clock speed. For proper envelope generation, CT and FT cannot both be zero.

Envelope shapes and corresponding binary codes are shown in Fig. 1. We want a triangle wave (on a log scale)



FIG. 4—THE AUTHOR'S CUSTOM CABLE, which is used to connect the Synergy Card to an audio system.

starting at amplitude zero. There is one trick to remember when calculating frequencies for that waveform: The equation is set up for the sawtooth envelopes, and the triangle wave takes twice as much time per wave. So we'll use 0.20 Hz and 0.24 Hz to obtain the correct values. For an f_{EN} of 0.20, CT should be 140 and FT should be 160. For an f_{EN} of 0.24, CT should be 117 and FT should be 48.

Enable Voice A in PSG 0 and PSG 2 by writing 55 to registers 7 and 39. Write the CT and FT values to the appropriate registers. Next write a 14 to registers 13 and 45; that selects our envelope shape.

The noise frequency is governed by the simple equation:

$$f_N = f_{CL} / (16 \times P_N)$$

In that equation, f_N is the desired noise frequency, f_{CL} is the clock speed, and P_N is the value in the Noise Period register. NP can range from 1 to 31. For this example, write a 1 to registers 6 and 38. Last, turn on the volume by writing a 16 to registers 8 and 40. Now you should hear a surf-like sound coming from your audio system.

At this time, evaluate the signal level arriving at your stereo. The potentiometers on the Synergy Card control that level; one for each channel. Adjust them for maximum volume, and balance between the two channels.

Conclusion

You'll probably want to experiment with envelope shape(s), volume, number of layers, carrier frequency, and Synergistic Sound frequency. **Warning: Avoid 13–15 Hz beat frequencies, which have been known to cause epileptic seizures in those prone to them.**

Much could be said about how you can use the 60 bits of I/O. For example, to build an inexpensive isolated controller, you could use the Synergy Card to drive transistors, which would in turn drive relays. Or you could drive a DAC, which would drive a VCO, and use it to transmit data over phone lines. Or have it read in-coming digital data. As a reader of **Computer Digest**, you probably have some ideas of your own.

The author wishes to thank Montana Micro for technical assistance, Jameco Electronics for supplies and equipment, and Brady Books for technical references. ♦♦♦

R-E Computer Admart

Rates: Ads are 2 1/4" x 2 7/8". One insertion \$900. Six insertions \$875. each. Twelve insertions \$845. each. Closing date same as regular rate card. Send order with remittance to Computer Admart, Radio Electronics Magazine, 500-B Bi-County Blvd., Farmingdale, NY 11735. Direct telephone inquiries to Arline Fishman, area code-516-293-3000. Only 100% Computer ads are accepted for this Admart.

ON TARGET ASSOCIATES

Products and Services
for Design and Manufacturing Engineers.

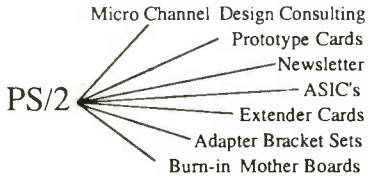

We will move your PC/XT/AT products to the Micro Channel, or create your new design.

CALL: (408) 980-7118
for our Free catalog

ON TARGET
TARGET
TARGET

...the PS/2 leaders.

PS/2 and Micro Channel are trademarks of IBM Corp.

CIRCLE 203 ON FREE INFORMATION CARD

ICs PROMPT DELIVERY!!!

SAME DAY SHIPPING (USUALLY)

QUANTITY ONE PRICES SHOWN for AUG. 9, 1988

OUTSIDE OKLAHOMA: NO SALES TAX

DYNAMIC RAM			
SIMM	1048Kx9	85 ns	\$550.00
1Mbit	1048Kx1	100 ns	38.50
41256	256Kx1	60 ns	14.25
41256	256Kx1	80 ns	13.75
41256	256Kx1	100 ns	13.50
51258	+ 256Kx1	100 ns	12.95
41256	256Kx1	120 ns	12.75
41256	256Kx1	150 ns	11.75
41264	+ 64Kx4	120 ns	18.95
EPROM			
27C1000	128Kx8	200 ns	\$37.50
27C512	64Kx8	200 ns	13.95
27256	32Kx8	250 ns	7.25
27128	16Kx8	250 ns	6.60
STATIC RAM			
43256L-10	32Kx8	100 ns	\$18.95
3264P-12	8Kx8	120 ns	13.50

OPEN 6 1/2 DAYS, 7:30 AM-10 PM. SHIP VIA FED-EX ON SAT

WE EXPORT ONLY TO CANADA, GUAM, PUERTO RICO & VIRGIN ISLANDS

SAT DELIVERY INCLUDED ON FED-EX ORDERS RECEIVED BY: Th: Sat AM 06:30; Fr: P:1 5:00-11:00. MasterCard/VISA or UPS CASH COOD. Factory New, Prime Parts μ P MICROPROCESSORS UNLIMITED, INC. 21,000 S. Peoria Ave. BEGGS, OK 74421 (918) 267-4961. No minimum order. Please note that prices are subject to change. Shipping & insurance extra. & up to \$1 for packing materials. Orders received by 9 PM CST can usually be delivered the next morning, via Federal Express Standard Air or \$6.00, or guaranteed next day Priority One or \$10.25!

CIRCLE 61 ON FREE INFORMATION CARD

Fix common problems fast!

You don't need to be an expert to diagnose and correct problems involving PC setup. All you need is HELPMETM software! More than 300 tests. On-screen help for understanding and correcting identified problems. Quick identification of system configuration and compatibility. \$99 plus shipping and handling. MC and VISA accepted. California Software Products, Inc., 525 N. Cabrillo Park Drive, Santa Ana, CA 92701, (714) 973-0440.

CIRCLE 202 ON FREE INFORMATION CARD

RS-232

continued from page 89

It's too late for that type of solution; there are simply too many systems out there now using the old standard, and all that equipment would all become obsolete, or at best incompatible.

However, in recent years, several IC manufacturers (including Maxim Integrated Products and Linear Technology) have come up with clever devices that allow you to create and use voltages that fall within the EIA-232-D standard from only a +5-volt supply. In addition to the necessary line drivers and receivers, the devices contain a charge pump. Supplied with several high-value capacitors and a source of +5 volts, the IC's can swing an EIA-232-D \pm 10 volts. Typical applications of the Linear Technology and Maxim devices are shown in Figs. 3-a and 3-b respectively. Both companies sell a number of similar devices in various configurations; contact them at the addresses in the Sources box for more information.

Making connections

Pin 1 is no longer defined as protective ground, but as the shield. It's normally grounded to the case of the DTE; the other end is usually left open to prevent ground loops. The actual signal ground must be returned through pin 7; pins 1 and 7 should never be connected together. Doing so could induce noise in the signal ground or cause ground-loop currents.

In implementing a serial interface, some devices use as few as three leads (TD, RD, and GND); others add an additional line (pin 20 or pin 11) for "busy" processing; yet others use all 22 defined lines.

The most commonly used signals are 1-8, and 20. Pins

11, 12, and 22 are also fairly common. Pin 11 is used sometimes (especially in Europe) as a "Printer Busy" signal. Pin 12 may be used as a high-speed indicator; in that case, it is active if the device is transmitting at 2400 baud or greater. Pin 22 is a handshaking line that functions in a complementary manner to pin 20.

Conclusions

In this brief treatment, we have tried to outline the features of the new serial-interface standard. The information presented here should help you understand the ideal, and may help you solve your next interfacing problem. Happy interfacing! \blacktriangleright \blacktriangleleft

Sources

- Electronic Industries Association, 2001 Eye Street N. W., Washington, DC 20006. (202) 457-4900.
- Linear Technology Corporation, 1630 McCarthy Blvd., Milpitas, CA 95035-7487. (408) 432-1900.
- Maxim Integrated Products, 510 N. Pastoria Ave., Sunnyvale, CA 94086. (408) 737-7600.



"It always smokes after interfacing."

EDITOR'S WORKBENCH

continued from page 86

add a standard 360K drive. Last, the MatchMaker allowed me to run the external Macintosh drive. The only problem was that I used up all my expansion slots, so I'm wondering where to install my CD-ROM controller card. Any ideas? 



New Windows, New DOS

Microsoft has just released a new version of Windows, the key feature of which is a software driver, HIMEM.SYS, that gives you an extra 50K of memory in the Windows environment. The extra memory translates into more speed, because large applications like PageMaker

and Excel won't have to page overlays to disk as often. In addition, the product's speed has been enhanced, many printer drivers have been added, and the installation procedure has been simplified. Although Windows/286 Version 2.1 will run on 8088- and 8086-based PC's, performance will be less than optimal. In addition, HIMEM.SYS requires extended memory (that above 1MB) to work, and 8088-based PC's do not support extended memory.

The same memory-management technology has been incorporated into Windows/386 Version 2.1, which requires an 80386- or 80386SX-based PC to run, and provides multiple independent virtual DOS machines, each of which can run its own DOS environment with as much as 640K of memory. Unlike Windows/286, Windows/386 allows standard DOS applications (for example, Lotus, dBASE, WordStar, etc.) to run simultaneously in on-screen windows.

DOS 4.0

IBM has just released the first major upgrade of DOS in almost a year and a half. The new version provides support for expanded (EMS 4.0) memory, hard-disk partitions greater than 32MB, easier installation, and a DOS shell (used to manipulate files and to run applications from

menus). Also, a separate product containing DOS 4.0 and a custom version of Windows/286 has been introduced; according to IBM, the Windows Kit contains a set of applications, including a word processor, a spelling checker, an equation editor, and graphing. The latter capabilities should be especially useful to our readers; we'll have a report as soon as we can get our hands on a copy.

Hypertext

Last fall Apple released a program called HyperCard that it now includes with every Macintosh. HyperCard is the first and most widespread implementation of a concept called Hypertext. The concept originated with a man named Ted Nelson about 20 years ago, but only during the past few years have people had enough computing horsepower to do anything serious with Hypertext.

True Hypertext is actually a multi-media phenomenon, involving text, sound, graphics, and even motion. What makes Hypertext special is that it's like an infinitely extensible database, allowing, for example, a chunk of text to link to a graphic image, which may link to a musical score, which may link to the original text, etc. Given those capabilities, Hypertext may be the ideal means of realizing CD-I (interactive compact disks).

Because of HyperCard's run-away success, now every company with a free-form database or text-search program claims Hypertext capabilities. Those claims are universally exaggerated, but even so, several products having little to do with real Hypertext, are still very interesting in their own right.

One is called Ize; it's sold by Persoft, Inc. (465 Science Drive, Madison, WI 53711, (608) 273-6000). The program allows you to create outline-like structures that can provide multiple links into groups of files. For example, you could specify resistors, capacitors, and inductors as outline categories, and then have the program scan for files using those terms. Then other outline elements would link you to documents with various combinations of those terms.

Another program developed and sold by Seaside Software (P.O. Box 1428, Perry, FL 32347, (800)-3-ASKSAM) is called AskSam. AskSam allows you to create free-form databases with both fielded information (name, address, phone number, etc.) and non-fielded information ("random" notes). A simple reporting language lets you print out the desired information. You could use the program to maintain a name and address file along with notes about each person in the file. You could print Rolodex cards with the field information, and exclude the notes 

Why Take Chances... Use The Breath Alert®



The BREATH ALERT® provides fast and accurate readings of blood alcohol concentration (BAC) by electronically measuring the alcohol content on exhaled breath. It was designed for personal use to demonstrate to you that it does not take as much alcohol to become legally intoxicated as you may have previously thought.

Drivers should use The BREATH ALERT® to test themselves. When you get arrested for drunk driving, you can lose your license and most likely your job. The BREATH ALERT® can provide you with the chance to know your BAC before it is too late.

The BREATH ALERT® can be used as a preliminary tester with an optional disposable moisture trap.

The BREATH ALERT® uses the same sensor as the \$400 and \$500 models that are used by law enforcement agencies. The BREATH ALERT® alarm will sound to alert you not to drive.

The BREATH ALERT® is manufactured under strict quality control conditions to ensure optimum performance and reliability.



30 DAY MONEY BACK GUARANTEE (ON ASSEMBLED UNITS)
90 DAY MFG. WARRANTY

FOR IMMEDIATE SHIPMENT ORDER BY CREDIT CARD OR C/D

CREDIT CARD CUSTOMERS CALL TOLL FREE ANYTIME 1-800-334-0854 EXT. #509 FOR C/D ORDERS CALL 1-617-437-4609 ANYTIME PLEASE ADD \$4.50 FOR SHIPPING AND HANDLING. SEND PREPAID ORDERS TO: BREATH ALERT MFG. CO. 130 ROCKLAND ST. HANOVER, MA. 02339

BREATH ALERT®

NOTE! THIS INVESTMENT COULD SAVE YOUR LIFE

KIT (BA-101-D)
DELUXE KIT: Complete parts with case \$59.95
READY TO GO BUILT AND CALIBRATED (BA-1 B)
comes with ac charger and manual \$99.95

QUANTITY DISCOUNTS AVAILABLE CALL OR WRITE



Try the
**Radio
Electronics**

bulletin board
system

(RE-BBS)
516-293-2283

The more you use it the
more useful it becomes.

We support 300 and 1200
baud operation.

Parameters: 8N1 (8 data
bits, no parity, 1 stop bit)
or 7E1 (7 data bits, even
parity, 1 stop bit).

Add yourself to our user
files to increase your
access.

Communicate with other
R-E readers.

Leave your comments on
R-E with the SYSOP.

RE-BBS
516-293-2283

PC SERVICE

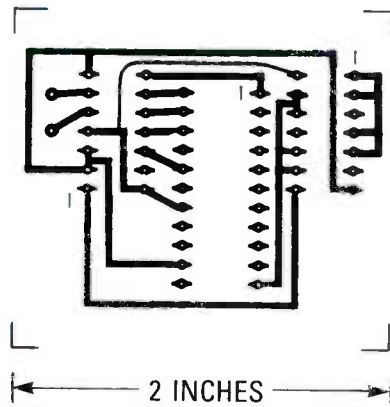

THE FOIL PATTERN FOR the pulse dialer retrofit board.

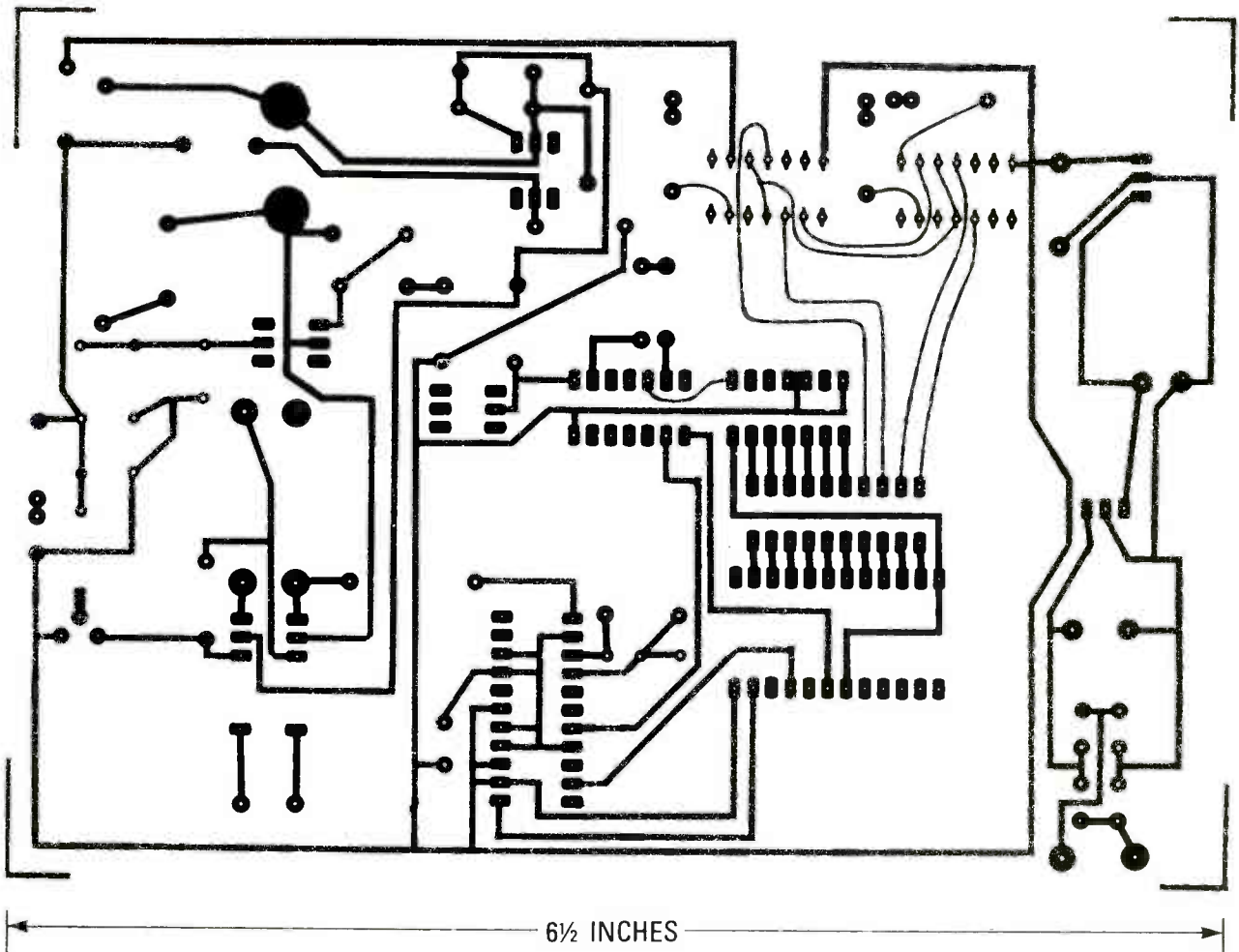

THE SOLDER SIDE of the Tele-Guard II.

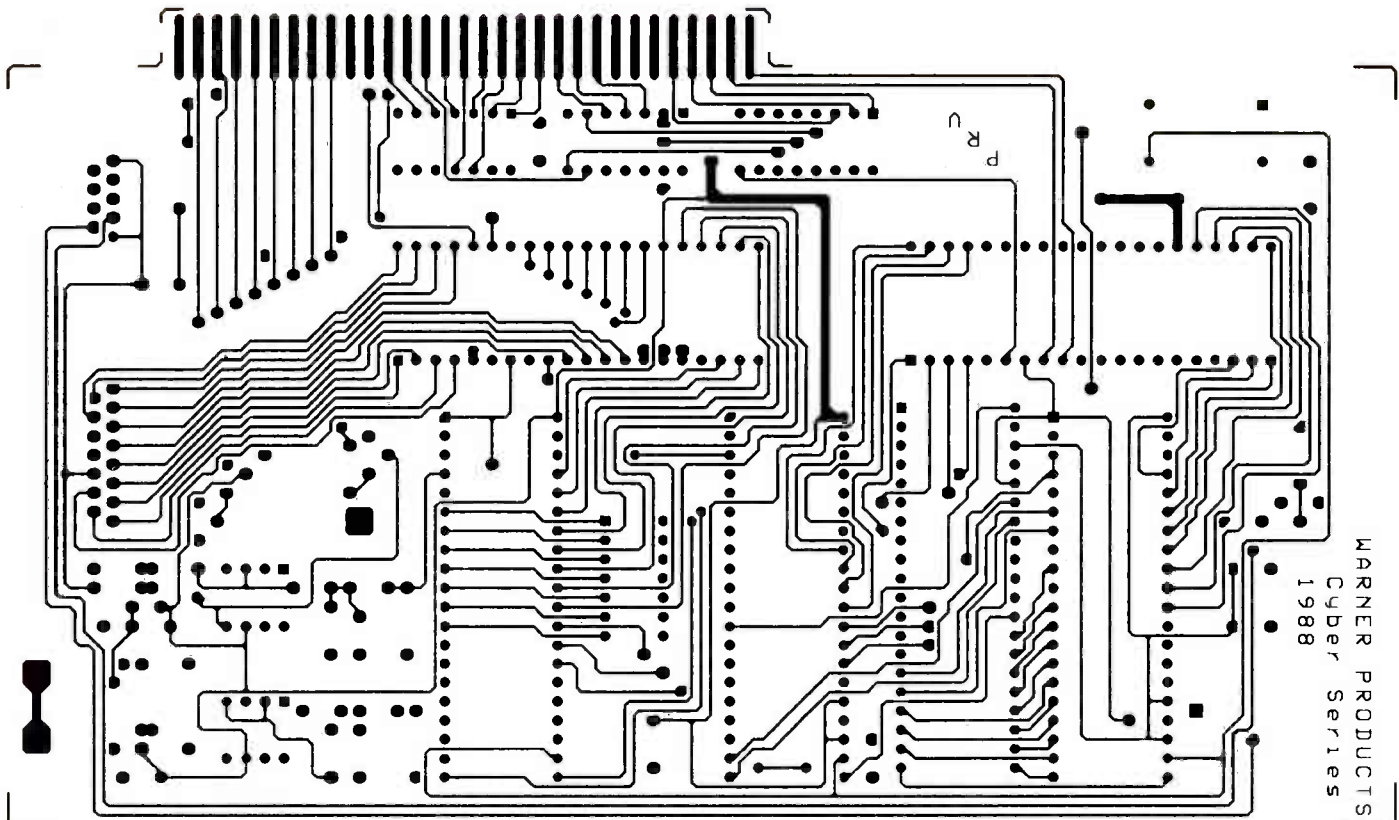

WARNER PRODUCTS
Cyber Series
1988

7-14 INCHES

THE COMPONENT SIDE OF THE Synergy card.

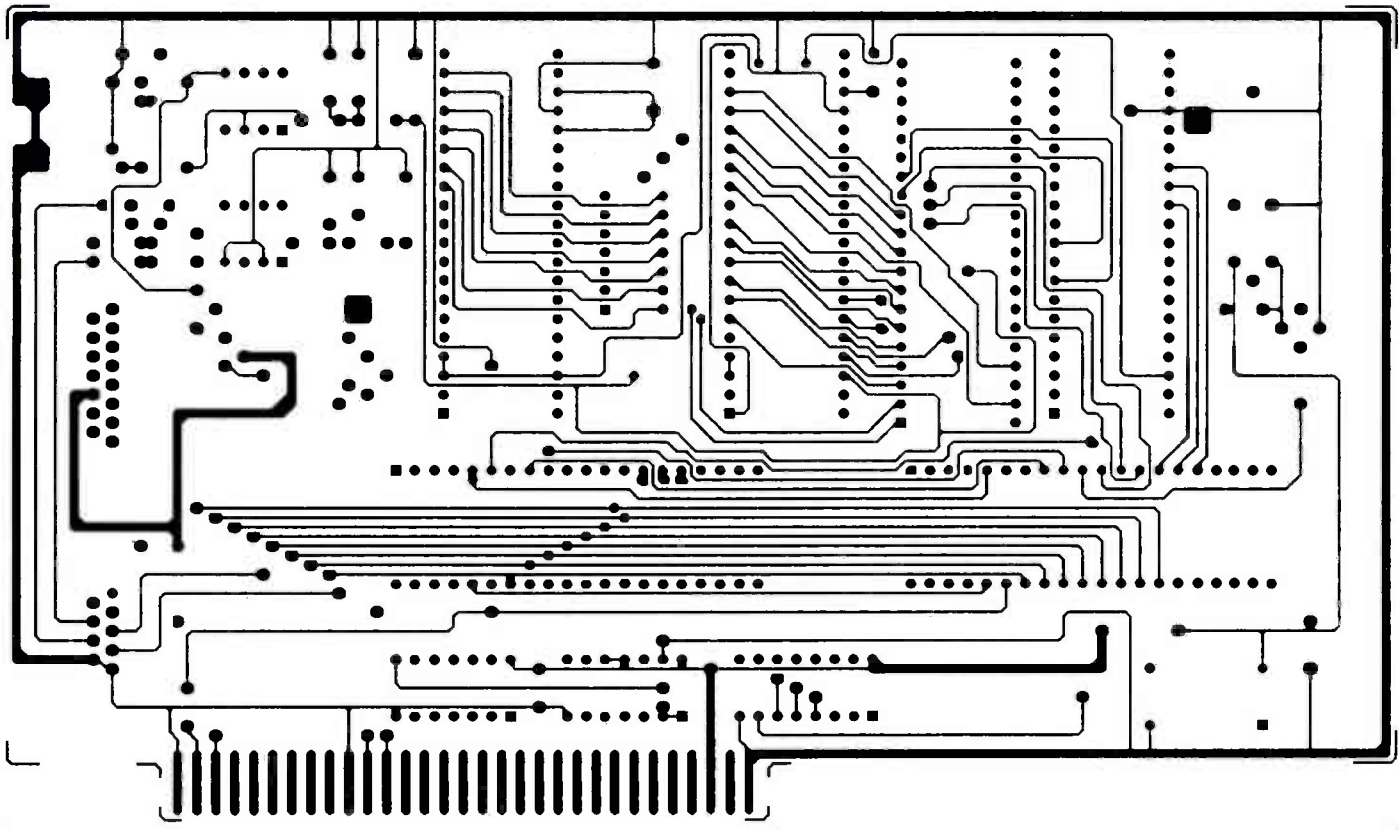

7 1/4 INCHES

RADIO-ELECTRONICS

THE SOLDER SIDE OF THE Synergy Card.

R-E Engineering Admart

Rates: Ads are 2 1/4" x 2 7/8". One insertion \$900. Six insertions \$875. each. Twelve insertions \$845. each. Closing date same as regular rate card. Send order with remittance to **Engineering Admart**, Radio Electronics Magazine, 500-B Bi-County Blvd., Farmingdale, NY 11735. Direct telephone inquiries to Arline Fishman, area code-516-293-3000. **Only 100% Engineering ads are accepted for this Admart.**

MIDI PROJECTS



BP182—MIDI interfacing enables any so equipped instruments, regardless of the manufacturer, to be easily connected together and used as a system with easy computer control of these music systems. Combine a computer and some MIDI instruments and you can have what is virtually a programmable orchestra. To get your copy send **\$6.95 plus \$1.25 for shipping** in the U.S. to **Electronic Technology Today Inc., P.O. Box 240, Massapequa Park, NY 11762-0240.**

FCC LICENSE PREPARATION

The FCC has revised and updated the commercial license exam. The **NEW EXAM** covers updated marine and aviation rules and regulations, transistor and digital circuitry. **THE GENERAL RADIOTELEPHONE OPERATOR LICENSE - STUDY GUIDE** contains the necessary preparation for **ONLY \$25.00.**

WPT PUBLICATIONS
979 Young Street, Suite A
Woodburn, Oregon 97071
Phone (503) 981-6122

CIRCLE 192 ON FREE INFORMATION CARD

NO WAITING FOR COMPLETE, LOW PRICED, CHIP COMPONENT KITS

CC-1 Capacitor Kit contains 365 pieces, 5 ea. of every 10% value from 1p1 to .33p1. CR-1 Resistor Kit contains 1540 pieces; 10 ea. of every 5% value from 100 to 10 megΩ. Sizes are 0805 and 1206. Each kit is **ONLY \$49.95** and available for immediate One Day Delivery!

Order by toll-free phone, FAX, or mail. We accept VISA, MC, AMEX, COD orders, or company PO's with approved credit. Call for free detailed brochure.



COMMUNICATIONS SPECIALISTS, INC.
426 West Telf Avenue - Orange, CA 92665-4296
Local (714) 998-3021 - FAX (714) 974-3420
Entire U.S.A. 1-800-854-0547

CIRCLE 177 ON FREE INFORMATION CARD

DRAWING BOARD

continued from page 77

parts from a supplier on Neptune (prices are cheap but the postage is a killer).

The basic operation of a dynamic RAM is simple. You latch the row address in with **RAS** and then latch the column address with **CAS**, and then do either a read or write. Since the DRAM's storage cells are nothing more than really small (really, *really* small) capacitors, they have to be refreshed periodically. That means performing the task of reading the data and then writing it back into every cell every 2 milliseconds.

If you had to do that operation on all 65,536 cells individually, there wouldn't be any point to using DRAM but, fortunately, a refresh is much easier than that. Notice that I said "easier," not easy.

Standard DRAM's contain on-chip circuitry that refreshes a whole row of cells whenever any cell in the row is accessed. Refreshing an entire chip, therefore, means addressing each row within the 2-millisecond time limit. And that's where Matt's problem makes its appearance.

The memory matrix in most 64K DRAM's is made up of 128 rows and

512 columns. From the point of view of refresh, those IC's need a refresh counter that can address 128 rows—and for that you need seven address lines (2⁷ is 128). However, some manufacturers such as National, Signetics, and Texas Instruments (among others), made 64K DRAM's that had a memory matrix made up of 256 rows and 256 columns. As you can imagine, all of those IC's needed an eight-line refresh counter.

The official reason that most of those manufacturers gave for the design was that only half as many sense amplifiers were needed as in the 128 x 512 design and fewer amplifiers meant less heat and lower power requirements.

Big deal.

A minor reduction in power is no compensation for all the added design headaches. Remember that since you have to address twice as many rows with a 256 x 256 IC, it's going to take twice as long to get the job done. And that can mean increasing the system clock, having to use faster DRAM, and a host of other restrictions. The most serious problem is that it's going to cut the allowable Z-80 idle time in half and that's important in a system such as the one we have put together because we're using DMA to talk to the memory.

If you've followed our entire dis-

cussion on refresh over the last several months, you should have come away from it with one big fact uppermost in your mind—refresh circuitry is a super-colossal pain in the neck. The hardware and timing hassles generate an absolutely unbelievable amount of brain damage. As a matter of fact, it's well known that spending more than a couple of weeks on the problem will turn your brain into oatmeal. That's a scientific fact—you can look it up, the studies are frightening.

Anyway, if you've got some of those parts and you've determined to use them, the circuit in Fig. 3 is an applications note that appeared in the May 22, 1980 issue of *Electronics* magazine, and it can be used to handle the problem. It uses a counter to generate the extra address line and, while it will get the job done, be sure to redo all of the timing calculations that we went through when designing our circuit.

Another interesting letter brought up two points on this subject and came from Ron Olyink in Thorndale, Ontario. The first point he mentions is that **CAS** has to go high by the end of T2 rather than T4 because holding it low (active) will result in refreshing only the cell being addressed rather than

continued on page 105

MARKET CENTER

FOR SALE

TUBES, new, unused. Send self-addressed, stamped envelope for list. **FALA ELECTRONICS**, Box 1376-2, Milwaukee, WI 53201.

PHOTOFACT folders, under #1400 \$4.00. Others \$6.00. Postpaid. **LOEB**, 414 Chestnut Lane, East Meadow, NY 11554.

TRANSISTORS-tubes: MRF421 \$24.00, MRF454 \$14.50, MRF455-MRF477 \$11.75, MRF492 \$16.00, SRF2072 \$12.75, SRF3800 \$17.50, 2SC2290 \$16.75, 2SC2879 \$22.00, 6LF6, 6LQ6, 6JS6, 8950, etc.-call. New **Ranger AR3500** all mode 10 Meter transceiver \$319.00. Quantity discounts! Best prices on hard-to-find parts, antennas, mics, power supplies, & equipment! Catalog \$1.00 (refundable), or free with order. **RFPC**, Box 700, San Marcos, CA 92069. For information or same day shipment—call (619) 744-0728. Visa/MC/C.O.D.

LASERS, components and accessories. Free catalog. **M.J. NEAL** Company, 6672 Mallard Court, Orient, OH 43146.

PICTURE flyer lists quality surplus electronics at low prices. Since 1970. Send for the last 3 issues. **STAR-TRONICS**, Box 683, McMinnville, OR 97128.

SATELLITE & cable equipment. This month's special (Varactor Tuners) Matsushita, Mitsumi, Magnavox, Sylvania, Philips, etc. Most are new \$19.95 **HIT-TECH ELECTRONICS**, P.O. Box 42423, Detroit, Mi. 48242 (313)722-9381.

CB RADIO OWNERS!

We specialize in a wide variety of technical information, parts and services for CB radios, 10-Meter and FM conversion kits, repair books, plans, high-performance accessories. Over 12 years of satisfied customers! Catalog \$2.

CBC INTERNATIONAL

P.O. BOX 31500RE, PHOENIX, AZ 85046

TUBES, name brands, new, 80% off list. **KIRBY**, 298 West Carmel Drive, Carmel, IN 46032.

IS it true... jeeps for \$44 through the government? Call for facts! 1-(312) 742-1142, ext. 4673.

TUBES. "Oldest," "latest." Parts and schematics. **SASE** for list. **STEINMETZ**, 7519 Maplewood Ave., R.E., Hammond, IN 46324.

GREAT buys! Surplus prices, ICs, linears, transformers, PS, stepping motors, vacuum pump, phototransistor, meters, Isase, **FERTIK'S**, 5400 Ella, Phila., PA 19120.

TWO-WAY-RADIO, PC COMPUTERS, UNIDEN SERVICE. General Radiotelephone licensed technician. Catalog-**RAYS**, 2025 Moline, Ft. Worth, TX 76117 (817) 831-7717.

AIDS? Yes we have! Cable aids to help you. Zenith, Jerrold, Scientific Atlanta, Oak, Hamilns, much more. No Michigan sales! **HOTRONICS**, (313) 675-5834.

Multi-Channel Microwave T.V. Receivers



1.9-2.7 GHz Parabolic Dish 40+ dB Gain
LIFETIME WARRANTY
Complete System \$99.95 (Shipping Incl.)
Replacement Components
& Expert Repairs Available
K & S ELECTRONICS Call now for same
P.O. BOX 34522 day shipping!
PHOENIX, AZ 85067 (602) 230-0640
\$2 CREDIT ON PHONE ORDERS

VISA/MC/COD

PC products—A/D, D/A, relay, digital I/O cards starting at \$79. Free catalog—parts, kits, computers. **JB COMPU-TRONIX**, 3816 N. Wadsworth Blvd., Wheat Ridge, CO 80033. Call (303) 425-9586.

SOLAR electric systems. Discount prices. **SUN POWER-TEXAS**, Dept. 01C, P.O.B. 2788A Freeport, TX 77541. 1-(409) 233-8350.

LOW prices, capacitors, ICs, transistors, switches. Flyer **SASE SANTECH**, 11 Revere Place, Tappan, NY 10983. (914) 359-1130.

NEW 100Mhz Logic Analyzer Requires PC or compatible. Asking \$1200.00. Call **MATT** (303) 963-1969

CLASSIFIED AD ORDER FORM

To run your own classified ad, put one word on each of the lines below and send this form along with your check to:

Radio-Electronics Classified Ads, 500-B Bi-County Boulevard, Farmingdale, NY 11735

PLEASE INDICATE in which category of classified advertising you wish your ad to appear. For special headings, there is a surcharge of \$23.00.

() Plans/Kits () Business Opportunities () For Sale
() Education/Instruction () Wanted () Satellite Television
()

Special Category: \$23.00

PLEASE PRINT EACH WORD SEPARATELY, IN BLOCK LETTERS.

(No refunds or credits for typesetting errors can be made unless you clearly print or type your copy.) Rates indicated are for standard style classified ads only. See below for additional charges for special ads. **Minimum: 15 words.**

1	2	3	4	5
6	7	8	9	10
11	12	13	14	15 (\$42.75)
16 (\$45.60)	17 (\$48.45)	18 (\$51.30)	19 (\$54.15)	20 (\$57.00)
21 (\$59.85)	22 (\$62.70)	23 (\$65.55)	24 (\$68.40)	25 (\$71.25)
26 (\$74.10)	27 (\$76.95)	28 (\$79.80)	29 (\$82.65)	30 (\$85.50)
31 (\$88.35)	32 (\$91.10)	33 (\$94.05)	34 (\$96.90)	35 (\$99.75)

We accept MasterCard and Visa for payment of orders. If you wish to use your credit card to pay for your ad fill in the following additional information (Sorry, no telephone orders can be accepted.):

Card Number

Expiration Date

Please Print Name

Signature

IF YOU USE A BOX NUMBER YOU MUST INCLUDE YOUR PERMANENT ADDRESS AND PHONE NUMBER FOR OUR FILES. ADS SUBMITTED WITHOUT THIS INFORMATION WILL NOT BE ACCEPTED.

CLASSIFIED COMMERCIAL RATE: (for firms or individuals offering commercial products or services) \$2.85 per word prepaid (no charge for zip code). **MINIMUM 15 WORDS.** 5% discount for same ad in 6 issues; 10% discount for same ad in 12 issues within one year; if prepaid. **NON-COMMERCIAL RATE:** (for individuals who want to buy or sell a personal item) \$2.30 per word, prepaid...no minimum. **ONLY FIRST WORD AND NAME** set in bold caps at no extra charge. Additional bold face (not available as all caps) 50¢ per word additional. Entire ad in boldface, \$3.40 per word. **TINT SCREEN BEHIND ENTIRE AD: \$3.55 per word. TINT SCREEN BEHIND ENTIRE AD PLUS ALL BOLD FACE AD: \$4.15 per word. EXPANDED TYPE AD: \$4.30 per word prepaid. Entire ad in boldface, \$5.15 per word. TINT SCREEN BEHIND ENTIRE EXPANDED TYPE AD: \$5.40 per word. TINT SCREEN BEHIND ENTIRE EXPANDED TYPE AD PLUS ALL BOLD FACE AD: \$6.25 per word. DISPLAY ADS: 1" x 2 1/4"—\$385.00; 2" x 2 1/4"—\$770.00; 3" x 2 1/4"—\$1155.00. General Information:** Frequency rates and prepayment discounts are available. **ALL COPY SUBJECT TO PUBLISHERS APPROVAL. ADVERTISEMENTS USING P.O. BOX ADDRESS WILL NOT BE ACCEPTED UNTIL ADVERTISER SUPPLIES PUBLISHER WITH PERMANENT ADDRESS AND PHONE NUMBER.** Copy to be in our hands on the 12th of the third month preceding the date of the issue. (i.e., Aug. issue copy must be received by May 12th). When normal closing date falls on Saturday, Sunday or Holiday, issue closes on preceding working day. Send for the classified brochure. Circle Number 49 on the Free Information Card.

CABLE-TV

WE'LL MATCH OR BEAT ANYONE'S ADVERTISED RETAIL OR WHOLESALE PRICES!

BONANZA!

ATTENTION, are you looking for surplus test equipment volt meters oscilloscope, etc. **J.B. ELECTRONICS**, 9518 W. Grand, Franklin Park, IL 60131. (312) 451-1750.

RESTRICTED technical information: Electronic surveillance, schematics, locksmithing, covert sciences, hacking, etc. **Huge selection. Free brochures. MENTOR-Z**, Drawer 1549, Asbury Park, NJ 07712.

CABLE TV converters. Remotes, accessories Tocom, Zenith, Oak, Jerrold, Scientific Atlanta—free catalog—**ARIZONA VIDEO**, 3661 N. Campbell, #310-A, Tucson, AZ 85719. (602) 323-3330.

TUBES 59c. Year guarantee. Free catalog. Tube checker \$8.95. **CORNELL**, 4215 University, San Diego, CA 92105.

FAIR prices SB-3, SX3, SA3, TRI-BI, MLD-1200-3. Some Oak, any notch filters. Small dealer only. No Michigan sales (313) 979-8356.

OLD radio TV schematics. Send \$3.00, make, model. **RADIO MAPS**, P.O. Box 791, Union City, CA 94587.

Quality Microwave TV Antennas

Multi-Channel 1.9 to 2.7 GHz. 40dB Gain
30-Channel System complete \$149.95
12-Channel System complete \$104.95
2-Channel System complete \$79.95

Phillips-Tech Electronics
P.O. Box 8583 • Scottsdale, AZ 85252
(602) 947-7700 (\$3.00 Credit all phone orders!)

LIFETIME WARRANTY MasterCard • Visa • COD's Quantity Pricing

DESCRAMBLERS. All brands. Special combo Jerrold 400 and SB3 \$165. Complete cable descrambler kit \$39. Complete satellite descrambler kit \$45.00. Free catalog. **MJM INDUSTRY**, Box 531, Bronx, NY 10461-0531.

ATTENTION LASER HOLOGRAPHIC EXPERIMENTERS: Optical Computer components, instructions. \$22.95 postpaid. **STELLAR TECHNOLOGIES**, 4710 University Way N.E., #1003, Seattle, WA 98105.

TRS-80 color computer software. Low prices! Huge selection! Free catalog. **T&D**, P.O. Box 1256, Holland, MI 49422.

IC's digital and linear, transistors, sockets, led's and memory devices for sale. Very low prices. No minimum order. For free catalog write to: **ARLI ELECTRONICS**, 1052 Ellinita Av., Glendale, CA 91208. Your postage returned with catalog.

FREE CATALOG

FAMOUS "FIRESTIK" BRAND CB ANTENNAS AND ACCESSORIES. QUALITY PRODUCTS FOR THE SERIOUS CB'er. SINCE 1962

FIRESTIK ANTENNA COMPANY
2614 EAST ADAMS
PHOENIX, ARIZONA 85034

Electronic Components—Capacitors, Resistors, etc. Write for complete listing and pricing. **PACE ELECTRONICS**, Box 67, Sodus, NY 14551.

FREE power supply, connectors (\$8.95 value) with TV Project Assortment #103 (February 1984 G. Sync article) contains PCB TOKO coils, transistors (BFQ85), IC's, diodes, article reprint. \$25.00. Five/\$112.50. Assortment #104, contains all other parts \$10.00. Shipping \$3.00. **MC/VISA, COD accepted. JIM RHODES, INC.**, P.O. Box 3421, Bristol, TN 37625.

Descramblers: In-band gated-sync. Replace SB-3 and Feb. 1984 R-E project. Much better performance. Much lower cost! \$79.90 each. Write for details and quantity pricing. **SIERRA-BRAVO**, P.O. Box 2983, Bremerton, WA 98310-0382

LASERS, 1 to 9 milliwatt, from \$30, write **MWK INDUSTRIES**, 9852 W. Katella, Suite 340, Anaheim, CA 92804

SAVE/make \$1000's high technology insider secrets catalog \$2.00. Exotic parts, **LEEWARE**, Box 5636, Greensboro, NC 27435.

ITEM	1 UNIT	10 OR MORE
F-AMLIN MCC 3000 36 CODED REMOTE CONVERTER (Ch 3 only)	29 00	18 00
PANASONIC WIRELESS CONVERTER (our best buy)	98 00	79 00
MOVIE TIME VR7200A (manual fine tune)	88 00	69 00
JERROLD 400 COMBO	169 00	119 00
JERROLD 400 HAND REMOTE CONTROL	29 00	18 00
JERROLD 450 COMBO	199 00	139 00
JERROLD 450 HAND REMOTE CONTROL	29 00	18 00
JERROLD SB-ADD-ON	99 00	63 00
JERROLD SB-ADD-ON WITH TRIMODE	109 00	75 00
TA-35 B COMBO UNIT (Ch 3 output only)	99 00	70 00
TA-35 B COMBO UNIT WITH VARISYNC	109 00	75 00
MINICODE (N-12)	99 00	62 00
MINICODE (N-12) WITH VARISYNC	109 00	65 00
MINICODE VARISYNC WITH AUTO ON-OFF	145 00	105 00
ECONOCODE (minicode substitute)	69 00	42 00
ECONOCODE WITH VARISYNC	79 00	46 00
MLD-1200-3 (Ch 3 output)	99 00	62 00
MLD-1200-2 (Ch 2 output)	99 00	62 00
ZENITH SSAVI CABLE READY	175 00	125 00
INTERFERENCE FILTERS (Ch 3 only)	24 00	14 00
EAGLE PD-3 DESCRAMBLER (Ch 3 output only)	119 00	65 00
SCIENTIFIC ATLANTA ADD-ON REPLACEMENT DESCRAMBLER	119 00	85 00

*CALL FOR AVAILABILITY

Quantity	Item	Output Channel	Price Each	TOTAL PRICE

California Penal Code #593-D forbids us from shipping any cable descrambling unit to anyone residing in the state of California.

Prices subject to change without notice.

SUBTOTAL	
Shipping Add	\$3.00 per unit
COD & Credit Cards — Add 5%	
TOTAL	

PLEASE PRINT

Name _____

Address _____ City _____

State _____ Zip _____ Phone Number () _____

Cashier's Check Money Order COD Visa Mastercard

Acct # _____ Exp. Date _____

Signature _____

FOR OUR RECORDS:

DECLARATION OF AUTHORIZED USE — I, the undersigned, do hereby declare under penalty of perjury that all products purchased, now and in the future, will only be used on cable TV systems with proper authorization from local officials or cable company officials in accordance with all applicable federal and state laws. **FEDERAL AND VARIOUS STATE LAWS PROVIDE FOR SUBSTANTIAL CRIMINAL AND CIVIL PENALTIES FOR UNAUTHORIZED USE.**

Dated: _____ Signed: _____

Pacific Cable Company, Inc.
7325½ RESEDA BLVD., DEPT. #R-11 • RESEDA, CA 91335
(818) 716-5914 • No Collect Calls • (818) 716-5140

IMPORTANT: WHEN CALLING FOR INFORMATION
Please have the make and model # of the equipment used in your area. Thank You

© Copyright 1987 PACIFIC CABLE CO., INC.

NOVEMBER 1988

SCRAMBLE FACTS

718-343-0130

PHONE TODAY for 3 minutes of satellite TV industry news, technical tips, and new product information.

DESCRAMBLING, new secret manual. Build your own descramblers for **cable and subscription TV**. Instructions, schematics, for SSAVI, gated sync, sinewave. (HBO, Cinemax, Showtime, etc.) \$8.95, \$2 postage. **CABLETRONICS**, Box 30502R, Bethesda, MD 20814.

PROJECTION TV...Convert your TV to project 7 foot picture... Easy!...Results comparable to \$2,500 projectors... **Plans and 8" lens \$24.95**...Professional systems available... Illustrated catalog free. **MACROCOMA**, 15GC Main Street, Washington Crossing, PA 18977...Credit card orders 24HRS. (215) 736-3979.

MANUFACTURE Electronic Equipment In Your home for the Army, Navy, Air Force, and NASA. Will supply plan. Inexpensive easy to build equipment. Government pays \$4,000. Cost you \$900. Profit \$3,100. Send \$10 to: **SUBCONTRACTOR&D**, 136-31 222 St., Laurelton, N.Y. DEPREE 11413., Attention: Wilner Nau.

EPROM Emulator/Programmer. IBM PC/XT compatible. Free info sheet. **SOLICON**, 8825 El Matador Dr., Gilroy, CA 95020.

FM transmitter 88 to 108 MHz kit \$12.95 Sierra Electronics. Box 709, Elfers, FL 34680-0709

POWER Supply Kit: Variable D/C voltage, fullwave bridge rectification. Complete: Transformer, PC board, Cabinet & Components. Satisfaction Guaranteed. \$29.95 + \$3.00 S/H. **KDC ELECTRONICS**, Box 5771, Bloomington, IN, 47401.

PRINTED circuit boards etched & drilled. Free delivery. **K & F ELECTRONICS, INC.**, 33041 Groesbeck, Fraser, MI 48026. (313) 294-8720.

BUILD this five-digit panel meter and square-wave generator including an ohms, capacitance and frequency meter. Detailed instructions \$2.50. **BAGNALL ELECTRONICS**, 179 May, Fairfield, CT 06430.

CRYSTAL radio sets, plans, parts, kits, catalog \$1.00. **MIDCO**, 660 North Dixie Highway, Hollywood, FL 33020.

HOW to rewind power transformers to your specs. Instructions, \$7.95. **BROSS ELECTRONICS**, 350 Tremont Drive, Suite D-51, Dept. R11, Murfreesboro, TN, 37130.

NEURAL NETWORKS

AMAZING circuits simulate thought & sensory processing. Build associative memory, and more. Plans \$25. Free brochure. Author **MSEE, LP WEBER**, Box 621, Dept. RE-1103, Allenwood, NJ 08720.

SATELLITE TV

CABLE TV Secrets—the outlaw publication the cable companies tried to ban. HBO, Movie Channel, Showtime, descramblers, converters, etc. Supplier's list included \$8.95. **CABLE FACTS**, Box 711-R, Pataskala, OH 43062.

DESCRAMBLERS for movies, networks, \$175. video only. \$450 complete. Visa, MC accepted. Catalog \$4. **SKYWATCH**, 238 Davenport Road, Toronto, Ontario, Canada, M5R-1J6.

BIG PROFITS

ELECTRONIC ASSEMBLY BUSINESS

Start home, spare time. Investment knowledge or experience unnecessary. **BIG DEMAND** assembling electronic devices. Sales handled by professionals. Unusual business opportunity.

FREE: Complete illustrated literature
BARTA, RE-O Box 248
Wainut Creek, Calif. 94597

SCRAMBLING NEWS

Twenty plus pages of excellent information per month. News, product reviews, feedback, turn-ons, features, patents, circuits. Scene change detector for Orion. Z-TAC, SA, Zenith PM series. VC and the self-sufficient pirate. \$24.95/yr. Sample \$3. Pay TV and Satellite Descrambling Vol. 1 or 2 \$14.95 each. **Cable TV Security** \$12.95. Experiences with Videocypher \$14.95. Wireless Cable Hacking \$9.95. Satellite Systems under \$600. \$12.95. Any 3/\$28 or 6/\$42 of above. ST-1085 decoder schematic \$14.95. Z-Trap II eliminates flashing \$15.95. Z-BAG Bogus Address Generator \$19.95. Trap and Bag \$29.95. New Fall Catalog \$1.

**Shojiki Electronics Corp., 1552A Hertel Ave.
Buffalo, NY 14216, COD's. 716-284-2163**

SATELLITE TV receiver kits! Instruction manual, boards, semiconductor parts! 59° LNA's! LNB's! Ku-Band LNB's! Catalog \$1.00. **XANDI ELECTRONICS**, Box 25647, Dept. 21LL, Tempe, AZ 85285-5647.

SATELLITE T.V. systems, upgrades, featuring: Uniden, Chaparral, Tee-Comm, Toshiba, LNA's, LNB's, feeds, dishes. Best prices! Catalog \$1.00 (refundable). **CASCADE ELECTRONICS**, P.O. Box 414, Dundee, IL 60118.

VIDEOCYIPHER II descrambling manual, schematics, video and audio DES, cloning, muskateering, EPROM codes. (HBO, Cinemax, Showtime, adult channels.) \$13.95, \$2 postage. **CABLETRONICS**, Box 30502R, Bethesda, MD 20814.

FREE catalog. Systems, Upgrades, Houston, Uniden, Chaparral, etc. Save, \$\$\$\$. **SKYVISION**, 2009 Collegeway, Fergus Falls, MN 56537, (218) 739-5231.

SATELLITE TV systems, descramblers, programming, VCR's, TV's, CB's, telephones, at discount prices. **ELMIRA ELECTRONICS**, 8343 M-32, Elmira, MI 49730. (616) 546-3362.



6" x 9" COAXIAL SPEAKERS
Super buyout. Made in Japan by Pioneer for GM. Upgrade auto sound system. 6" x 9" woofer, 2 1/2" cone tweeter. 35 watts RMS, 50 watts max. 12 oz magnet, Dust cover. Sold in pairs. 8 lbs./pair. Limited quantities.

#300-220 **\$1450** (1-5 prs)
\$1195 (6 prs-up)

SPEAKERS AND COMPONENTS





EMPIRE



18" WOOFER
Made in U.S.A.
100 oz. magnet, 3" voice coil. 250 watts RMS, 350 watts max. 8 ohm, 30 Hz resonant frequency, 22-2700 Hz response. Efficiency: 95 dB, 1W/1M. Paper cone treated accordion surround. Net wt: 29 lbs.

#290-200 **\$9880** (1-3)
\$8950 (4-up)



15" WOOFER
Made in U.S.A.
60 watts RMS, 90 watts max. 1 1/2" voice coil. 8 ohm, 25-2500 Hz response. 20 oz magnet, paper cone with poly foam surround. 93 dB, 1W/1M sensitivity. Net weight: 7 lbs.

#290-160 **\$2895** Any Qty.



10" WOOFER
MADE IN U.S.A.
Super duty 34 oz. magnet, 2" voice coil. Paper cone, treated accordion surround. 100 watts RMS, 140 watts max. 8 ohm, 70Hz resonant frequency, response: 45-4000 Hz. Net weight: 8 lbs.

#290-098 **\$3150** (1-3)
\$2870 (4-up)



12" POLY WOOFER
Super duty, 40 oz. magnet. Polypropylene cone. 100 watts RMS, 145 watts max. 4-8 ohm compatible (6 ohm). 2" voice coil.

#290-125 **\$3680** (1-3)
\$3450 (4-up)



HORN TWEETER
Exponential horn design. Mylar dome. 3 1/2" x 3 1/2" 1800-20,000Hz response. 35 watts RMS, 50 watts max.

#270-050 **\$650** (1-9)
\$590 (10-up)

12" 3-WAY, 100 WATT SYSTEM
Pioneer design engineers carefully evaluated the performance characteristics of this speaker systems to ensure the best full range frequency response.

System includes: (1) #290-125 poly woofer, (1) #280-045 heavy duty 5/4" midrange, (1) #270-035 4" scft dome tweeter, (1) #260-210 3-way 100 watt crossover, (2) #260-255 50 watt L-pads, (1) #260-300 terminal, and (1) #260-340 woodgrain grill cloth. Recommended cabinet volume: 3.1 cu ft. Cabinet Kit Available #260-390 \$19.95 each

#12-100



3-WAY 100 WATT CROSSOVER
12 dB/octave rolloff. 800 Hz, 5000 Hz, 8 ohm. 100 watts RMS.

#260-210 **\$1250** (1-9)
\$995 (10-up)

\$7395
each

Save Over **\$1000**



WOODGRAIN GRILL CLOTH
Authentic woodgrain print design cloth. 36" x 60"

#260-340 **\$595** Per Yard



CALL TOLL FREE
1-800-338-0531

* 15 day money back guarantee. * \$10.00 minimum order. * We accept Mastercard, Visa, Discover, and C.O.D. orders. * 24 hour shipping. * Shipping charge = UPS chart rate (\$2.50 minimum charge). * Hours: 8:30 am - 6:00 pm EST, Monday - Friday. * Mail order customers, please call for shipping estimate on orders exceeding 5 lbs.

FREE CATALOG

AMAZING SCIENTIFIC & ELECTRONIC PRODUCTS

PLANS

Build Yourself — All Parts Available in Stock

LC7— BURNING CUTTING CO ₂ LASER	\$20.00
RUB4— PORTABLE LASER RAY PISTOL	\$20.00
TCCT— 3 SEPARATE TESLA COIL PLANS TO 1.5 MEV	\$25.00
IOG1— ION RAY GUN	\$10.00
GRA1— GRAVITY GENERATOR	\$10.00
EM11— ELECTRO MAGNET COIL GUN/LAUNCHER	\$8.00

KITS

With All Necessary Plans

MFT3K— FM VOICE TRANSMITTER 3 MI RANGE	\$49.50
WVMP7K— TELEPHONE TRANSMITTER 3 MI RANGE	\$39.50
BTC3K— 250,000 VOLT 10-14" SPARK TESLA COIL	\$249.50
LHC2K— SIMULATED MULTICOLOR LASER	\$44.50
BL5K— 100,000 WATT BLASTER DEFENSE DEVICE	\$69.50
ITMK— 100,000 VOLT 20" AFFECTIVE RANGE INTIMIDATOR	\$69.50
PSP4K— TIME VARIANT SHOCK WAVE PISTOL	\$59.50
STAIK— ALL NEW SPACE AGE ACTIVE PLASMA SABER	\$59.50
MVPK— SEE IN DARK KIT	\$199.50
PTG1K— SPECTACULAR PLASMA TORNADO GENERATOR	\$149.50

ASSEMBLED

With All Necessary Instructions

BC10— 50,000 VOLT-WORLD'S SMALLEST TESLA COIL	\$54.50
LGU40— 1MW HeNe VISIBLE RED LASER GUN	\$249.50
TAT30— AUTO TELEPHONE RECORDING DEVICE	\$24.50
GVP10— SEE IN TOTAL DARKNESS IR VIEWER	\$349.50
L1010— SNOOPER PHONE INFINITY TRANSMITTER	\$169.50
IPG70— INVISIBLE PAIN FIELD GENERATOR MULTI MODE	\$74.50

• CATALOG CONTAINING DESCRIPTIONS OF ABOVE PLUS HUNDREDS MORE AVAILABLE FOR \$1.00 OR USE OUR PHONE FOR "ORDERS ONLY" 603-673-4730.

PLEASE INCLUDE \$3.00 PH ON ALL KITS AND PRODUCTS PLANS ARE POSTAGE PAID. SEND CHECK, MO, VISA, MC IN US FUNDS.

**INFORMATION UNLIMITED
P.O. BOX 716 DEPT. RE, AMHERST, NH 03031**

CABLE TV DESCRAMBLERS

JERROLD™ Tri-Bi Mode	\$105.00	10 Lot	\$85.00
JERROLD™ SB-3 OR 2	\$89.00		\$65.00
Hamlin MLD-1200	\$99.95		\$62.00
Oak N-12 W/V.S.	\$99.95		\$62.00
Oak-M-35-B W/V.S.	\$99.00		\$78.00
OAK E-13	\$99.95		\$58.00
Zenith SS-AVI	\$185.00		\$145.00
Eagle PD-3	\$120.00		\$85.00
Scientific Atlanta	\$129.95		\$105.00
SA-Combo's	CALL		\$CALL
Tocom	\$350.00		\$295.00
Oak N-12 W/ Auto	\$140.00		\$105.00
Jerrold Starcom CSV	\$139.95		CALL

M.D. ELECTRONICS
WILL MATCH ANY
ADVERTISED PRICE
IN THIS MAGAZINE

*NEW STARGATE 2000 CABLE CONVERTER



1-\$89.00 10-\$69.00 100-Call

Last channel recall-Favorite channel select-75 channel-Channel scan-Manual fine tune-One year warranty-surge protection-HRC & Standard switchable- and much more. **Call Today!**

INFORMATION(402)554-0417

Orders Call Toll Free
1-800-624-1150

**M.D. ELECTRONICS
115 NEW YORK MALL
SUITE 133E
OMAHA, NE. 68114**

M.C.
VISA
C.O.D.

CIRCLE 53 ON FREE INFORMATION CARD

BUSINESS OPPORTUNITIES

EARN thousands with your own part time electronics business. I do. Free proof, information. **INDUSTRY**, Box 531, Bronx, NY 10461-0531.

EASY, lucrative. One man CRT rebuilding machinery. Free info: (815) 459-0666 **CRT**, 1909 Louise, Crystalake, IL 60014.

PROJECTION TV..Make \$\$\$'s assembling projectors...easy...results comparable to \$2,500 projectors...**Plans, 8" lens & dealers information \$22.50**...Professional systems available.... Illustrated catalog free. **MACROCOMA 15GC** Main Street, Washington Crossing, PA 18977. Creditcard orders 24hrs. (215) 736-2880.

YOUR own radio station! AM, FM, TV, cable. Licensed/unlicensed. **BROADCASTING**, Box 130-F11, Paradise, CA 95967.

PC Board Design, Documentation, Plotting, Services, EE Designer, Hiwire/Smartwork, Schema CAD SYSTEMS SUPPORTED. Call 609-586-4469.

ELECTRONIC Parts Bonanza. IC's Transistors, More. SASE for List. **MBK**, Box 160, West Milton, OH 45383.

MECHANICALLY inclined individuals desiring ownership of small electronics manufacturing business—without investment. Write: **BUSINESS**, 92.R, Brighton 11th, Brooklyn, NY 11235.

Cable TV Converters

Why Pay A High Monthly Fee?

Jerrold Products include "New Jerrold Tri-Mode," SB-3. Hamlin, Oak VN-12, M-35-B, Zenith, Magnavox, Scientific Atlanta, and more. (Quantity discounts) 60 day warranty. For fast service C.O.D. orders accepted. Send SASE (60 cents postage) or call for info (312) 658-5320. **MIDWEST ELECTRONICS, INC.**, 5143-R W. Diversey, Chicago, IL 60639. MC Visa orders accepted. No Illinois orders accepted. Mon.-Fri. 8 A.M.-5 P.M. CST

EDUCATION & INSTRUCTION

MAGIC! Four Illustrated lessons plus inside information shows you how. We provide almost 50 tricks including equipment for four professional effects. You get a binder to keep the materials in, and a one year membership in the International Society of Performing Magicians with a plastic membership card that has your name gold-embossed. You get a one year subscription to our quarterly newsletter, "IT'S MAGIC!" Order now! \$29.95 for each course +\$3.50 postage and handling. (New York residents add applicable state and local sales tax.) **THE MAGIC COURSE**, 500-B BiCounty Boulevard, Farmingdale, NY 11735 or telephone (516) 293-3000 and ask for Nancy Estrada.

F.C.C. Commercial General Radiotelephone license. Electronics home study. Fast, inexpensive! "Free" details. **COMMAND**, D-176, Box 2223, San Francisco, CA 94126.

ENGINEERING software for IBM-PC. CompDes...circuit design. CompMath... math tutor. CompView...digital signal analysis. \$49 each. (614) 491-0832. **BSOFT SOFTWARE**, 444 Colton Road, Columbus, OH 43207.

MASTER new skills fast through our short specialized home study courses. Condensed and highly effective! Passport to success! 50 choices! Diploma! **CIEE-12**, Box 20345, Jackson, MS 39209.

WANTED

INVENTORS! AIM wants—ideas, inventions, technology, improvements on existing products. We present ideas to manufacturers. **Confidentiality guaranteed.** Call toll free in U.S. and Canada **1-(800) 225-5800**.

INVENTIONS, ideas, technology wanted! Industry presentation/national exposition. 1-(800) 288-IDEA. **ISC-RAD**, 903 Liberty, Pittsburgh, PA 15222.

CABLE TV. "BOXES"

**Converters—Descramblers
Remote Controls—Accessories**

- ★ **Guaranteed Best Prices** ★
- ★ **1 Year Warranty—C.O.D.'s** ★
- ★ **Immediate Shipping** ★
- ★ **FREE CATALOG** ★

Call or Write
TRANS-WORLD CABLE CO.
12062 Southwest 117th Court, Suite 126
Miami, Florida 33186
800-442-9333

PRINTED CIRCUIT BOARDS AND ARTWORK LAYOUTS

LOW priced single, double sided boards. No minimum charge. CAD artwork at discounted prices. (704) 464-1164; **WE-KAN**, RT-3, Box 662-H, Conover, NC 28613.

CABLE-TV AT IT'S BEST NEW TOCOM DESCRABLERS

SCIENTIFIC Atlanta models 8500—8550 remote included...\$240.00. SB-3's...\$74.00. TRI-Bi's...\$95.00. SA-3's...\$99.00. Zenith (Z-Tac) descramblers...\$169.00. N-12 (Vari-sync)...\$89.00. M-35 B (Vari-sync)...\$99.00. Hamlin MLD-1200's...\$89.00. **80-Channel converters**...\$95.00. Dealer discount on (5) units. Call—**N.A.S. INTERNATIONAL**, (213) 631-3552.

DESCRAMBLER MODULE

LATEST technology alternative to Jerrold SB-3 or Radio-Electronics Feb. 1984 project. Featuring electronic tuning, AGC, auto-on/off, AD/DC power, mini-size. A&T, and more. For literature—**SOUTH-TECH DISTRIBUTING**, (813) 527-2190.

NUTS & VOLTS P.O. BOX #1116
MAGAZINE Pleasanton, CA 94566
714-932-7721

GIVE YOURSELF A BREAK—A PRICE BREAK!
NUTS & VOLTS WILL SAVE YOU MONEY
ON ELECTRONIC PARTS & EQUIPMENT
**PLUS SHOW YOU WHERE TO FIND UNIQUE,
UNUSUAL AND HARD-TO-FIND ITEMS.**

SUBSCRIBE TODAY!

A National Publication For The Buying And Selling Of Electronic Equipment

Subscription Rates	\$3.00 PER ISSUE
3rd Class Mail	USA
One Year	\$12.00
Two Year	\$21.00
Three Year	\$40.00
Telex Mail	
One Year USA	\$20.00
Canada Mexico	\$22.00
Air Mail	
FOREIGN	1 Yr \$55.00

CABLE TV CONVERTERS

CABLE TV converters. Scientific Atlanta, Jerrold, Oak, Zenith, Hamlin. Many others. "**New!**" Video Hopper "The Copy Killer". Visa, M/C & Amex. **1-(800) 826-7623. B&B INC.**, 10517 Upton Circle, Bloomington, MN 55431.

CAR-STEREO EQUIPMENT

BOOM boom subwoofer systems, electronic crossovers, audio power amplifiers, radio cassettes, CB's etc. Wholesale prices, catalog, information. **BOOM BOOM ELECTRONICS**, 2905 Las Vegas Blvd. North, #53RE, North Las Vegas, NV 89030. (702) 399-3139.

INVENTORS

INVENTORS! Can you patent and profit from your idea? Call **AMERICAN INVENTORS CORPORATION** for free information. Over a decade of service 1-(800) 338-5656. In Massachusetts or Canada call (413) 568-3753.

HIGH TECH ELECTRONICS

SCRAMBLER PHONES! Phone Bug Detectors! Electronic Countermeasures Equipment! Executive and personal protection products! And much more! Catalog \$3.00 (Refundable with first order) **DIVERSIFIED WHOLESALE PRODUCTS**, P.O. Box 1275, Redondo Beach, CA 90278.

DRAWING BOARD

continued from page 99

the entire row of cells. The second one is that MUX has to go low at the start of T3 instead of T4 in order for the refresh address to be presented to the DRAM's address pins.

Let's take the second point first. The actual refresh operation takes place just after the falling edge of T3. There was a screwup in the original timing diagram; it showed MUX going low after the start of T4. Sorry if that caused a problem. Ron, you're absolutely right—the timing diagram shown in June was wrong and doesn't agree with the circuit.

Figure 4 shows the correct diagram and MUX should go low one gate-delay time after RFSH. That's because the flip-flop that's generating it, IC4-a, has its set input connected to RFSH.

There are lots of refreshing schemes that can be used to handle DRAM, and the one used in

our circuit is similar to the "RAS-only refresh" Ron mentioned in his letter. What we're really doing is a "hidden refresh." That is really nothing more than a RAS-only refresh with an extended CAS cycle as shown in Fig. 4.

The major benefit of extending CAS is that the DRAM will keep its output in the same state that it was before RAS showed up. That means that the data written to or read from the RAM during T1 and T2 will remain available through T3 and T4 as well. If we cut CAS short, the DRAM output pins would float during the last half of the machine cycle. That could be useful in some circuits but I like to keep data around as long as possible. I still have my Captain Midnight Secret Squadron Decoder ring.

Once again we've managed to run out of room. Next time we'll continue our discussion on display multiplexing. In any event, we laid out a lot of good information here and if anyone out there thinks I've screwed up..... I probably have so let me know. R-E

Try the Radio-Electronics bulletin board system

(RE-BBS)
516-293-2283

The more you use it the more useful it becomes.

We support 300 and 1200 baud operation.

Parameters: 8N1 (8 data bits, no parity, 1 stop bit) or 7E1 (7 data bits, even parity, 1 stop bit).

Add yourself to our user files to increase your access.

Communicate with other R-E readers.

Leave your comments on R-E with the SYSOP.

RE-BBS
516-293-2283

CATALOG OR INFORMATION: (213)888-8988 IN CAL: 1-800-521-MARK

300W HQ HI-FI POWER AMPLIFIER (MONO) TA-3600 $\Delta\Delta\Delta$

QUASI-COMPLEMENTARY SYMMETRY WITH PARALLEL HIGH OUTPUT TRANSISTORS

- SPECIFICATIONS**
- *POWER OUTPUT: 300W (RMS) INTO 8 OHMS
 - 2450W (P.M.P.O.) INTO 8 OHMS
 - 540W (MUSIC POWER) INTO 8 OHMS
 - *LOAD IMPEDANCE: 4 OHMS OR 8 OHMS
 - *FREQUENCY RESPONSE: 10Hz-200,000Hz
 - *TOTAL HARMONIC DISTORTION: LESS THAN 0.05%
 - *INPUT SENSITIVITY AND IMPEDANCE AT 1kHz: 1V-1.4V 47K OHMS
 - *SUPPLY VOLTAGE: DC $\pm 75V$ OR AC 53V $\times 2$ BA
 - KIT/ASSM. WITH TESTED \$86/110
 - X-FORMER \$38.00

8 Digit 1GHz Multifunctional Counter FC-1000A

Frequency range: 10Hz-1GHz GUARANTEED 5Hz-1GHz typically
Input sensitivity: 10Hz-100MHz (100V, 20mV)
100MHz-1GHz (150V, 20mV)
Unit counting capacity: 99999999
Accuracy: ± 1 (count) 1000Hz and below
High function: Hold the last input signal (Max 8 digits)
Input impedance: 10k Ω DC-10k Ω AC
Dimensions: 3.69" (W) \times 3.7" (D) \times 3.1" (H)
ASSM. WITH TESTED & CAL. \$192.00

ELECTRIC MUSICAL INSTRUMENT

EK-38 \star



THIS PROGRAMMABLE KEYBOARD IS DESIGNED FOR BOTH FUN AND LEARNING. THIS INSTRUMENT WILL AUTOMATICALLY PRODUCE FIFTEEN FAMILIAR TUNES FOR INSTANT PLEASURE OR YOU CAN PLAY OTHER TUNES FROM RANDOM NOTES OF YOUR OWN.

SPECIFICATION

- 25 KEYS • MELODY STORAGE PLUS AUTO PLAY • ONE-KEY PLAY LETS THE BEGINNER ENJOY MELODY PLAY WITH EASE • 15 SONGS PRESET FOR DEMONSTRATION TUNE • BUILT-IN SPEAKER • VOLUME CONTROL • BATTERY OPERATED (4 AA-SIZE DRY CELLS) • DIMENSION (W \times D \times H) 15" \times 4.7" \times 1.4" • WEIGHT 0.8 LB. • EXTERNAL DC JACK

ONLY \$22.00

MARK V ELECTRONICS, INC.

8019, E. SLAUSON AVE.
MONTEBELLO, CA 90640
FAX: (213) 888-6868

PROFESSIONAL COLOR LIGHT CONTROLLER SM-328 \star



FEATURES:
1. FOUR GROUPS OF INDEPENDENT OUTPUT SYSTEM (1000W/CH, MAX, 4680W (100/117V)) 2. PROFESSIONAL COLOR CONTROL SYSTEM (KEY-BOARD TYPE) 3. INDEPENDENT INPUT SIGNAL ADJUSTMENT 4. FOUR GROUPS OF 1-DEPENDENT DIMMER CONTROL 5. SPEED CONTROL CHASER 6. AUTOMATIC CHASING CONTROL SYSTEM 7. FOUR KINDS OF SPECIAL CHASING PROGRAM 8. COMBINATION OF PROGRAM AND MUSIC CHASING EFFECTS 9. FORWARD/BACKWARD CHASING CONTROL SM-328 color light controller is specialized for ballroom, night club disco and advertisement lighting. It consists with several color control characteristics, which employ professional color control system and keyboard program selection. Therefore, it is capable of producing lighting effects by using chasing program and fluctuating musical signal. There are two kinds of lighting effects. The first type is controlled by "musical" signal. In order to adjust the brightness of four groups of lightings, each music signal will be separated into high, medium low A, and low B frequency range. Furthermore, each group of lightings is incorporated with an independent signal adjustment. The second kind is composed of electrical circuits and this is the main part for creating a special lighting effect. It has four chasing programs.
Dimensions: 14.5/16" \times 8.15/16" \times 3.1/16"
Ass. with tested \$150.00

COLOR LIGHT CONTROLLER TY-23B $\Delta\Delta\Delta$



As a result of the advanced technology, this unit can control various colorful spot lights or bulbs. The visual effect of which is most suitable to place like party, disco, electronic game centre and also in lighting for advertisements. Total output power is 3000W (1000W/CH) which can control 30 pieces of 100W or 600 pieces of 5W color light bulbs.
Kit \$71.50 Assembled with tested \$82.50

ELECTRONIC LOTTO Δ



• 0-49 DIGITS DISPLAY, SUITABLE FOR LOTTERY GAME
• AUTO-SHUT OFF POWER, SO POWER CONSUMPTION IS VERY LOW
• 0.5" GREEN LED DISPLAY WITH FANCY PLASTIC PANEL
• OPERATION VOLTAGE: 8V DC (BATTERY NOT INCLUDED)
• DIMENSIONS: 3.1" \times 2" \times 0.5"
KIT \$15.00 ONLY

TOLL FREE 1-800-423-3483 FOR ORDERS PAID BY ONLY

SHOWROOM HOURS: (PACIFIC TIME)
MON.-FRI. 9:30 to 5:30 SAT. closed.

Best for CHRISTMAS PARTY
FREE CATALOG

VIDEO/AUDIO SURROUND SOUND PROCESSOR SM-333 $\Delta\Delta$



It creates high quality simulated stereo Surround "Music Field" for most video types CD, LD, Surround Sound Encoding Disks, tapes, & etc. This processor employs the most updated IC at its heart. It is also equipped with a "DNR" DYNAMIC NOISE REDUCTION SYSTEM IC made by NATIONAL SEMICONDUCTOR to particularly filter out the annoying noise that is commonly found on tapes or CD disk. In addition, there is six LOW NOISE OP-AMPs and all in one board design, no other external connectors connect to the main board.

Other features include:
• Continuous Variable Audio Time Delay • Surround Effect & Level Control • Dynamic Noise Reduction System • High output signal (6.8V MAX) can match with any kind of Main Power Amp. • All metal construction for reliability & durability!

SPECIFICATIONS:
Frequency Response: 20Hz-20KHz (± 5 dB) • Total Harmonic Distortion: 0.05% 20Hz-20KHz (front channel) < 0.25% (surround channel) • Input Signal Voltage: 0.1V-3.5V • Output Voltage: 0.1V-3.5V (front channel) 6.8V Max. (surround channel) • Delay Time: 5ms-50ms • Input Impedance: 47K Ohms Power: AC 110V 80Hz • Dimensions: 4.3/16" (W) \times 1.1/16" (D) \times 2.1/16" (H)
KIT/ASSM. WITH TESTED \$72/93

ELECTRONIC ECHO AND REVERBERATION AMPLIFIER



Kit/Ass with tested \$93/30 \$116/80

TERMS: \$10 min. order • \$20 min. charge card order • Check, money order or phone order accepted • We ship UPS Ground • Add 10% of total order (min \$2.8) for shipping, outside USA add 20% (min \$5.00) • Transit Insurance: add 5% of total (outside USA only) • CA residents add sales tax • All merchandise subject to prior sale • Prices are subject to change without notice • Any goods proved to be defective MUST BE RETURNED IN ORIGINAL FORM WITH A COPY OF YOUR INVOICE WITHIN 30 DAYS FOR REPLACEMENT.

It's a must for every modern family!

ONLY
SAVE
YOU MORE
MONEY

Best for CHRISTMAS
FUN FUN FUN FUN

RECORDS W/ ECHO EFFECT YOURSELF!



AK, Puerto Rico - 218-681-6674 Telex - 62827914 FAX - 218 681-3380 TWX - 810508882 DIGI KEY CORP

INTEGRATED CIRCUITS

Table with columns: Part, Price, Description. Includes sections for 7400 TTL, 74500 TTL, 7400 CMOS, 74500 CMOS, 74000 CMOS, 74500 TTL.

1% METAL OXIDE FILM RESISTORS

Table with columns: Part, Price, Description. Lists various resistor values and tolerances.

5% WIREWOUND RES. RESISTORS

Table with columns: Part, Price, Description. Lists wirewound resistor specifications.

DISC CAPACITORS

Table with columns: Part, Price, Description. Lists disc capacitor values and types.

PACKAGED V-SERIES

Table with columns: Part, Price, Description. Lists packaged V-series components.

TRANSFORMERS

Table with columns: Part, Price, Description. Lists transformer specifications.

4000 CMOS

Table with columns: Part, Price, Description. Lists 4000 CMOS series components.

7400 CMOS

Table with columns: Part, Price, Description. Lists 7400 CMOS series components.

74500 TTL

Table with columns: Part, Price, Description. Lists 74500 TTL series components.

74500 CMOS

Table with columns: Part, Price, Description. Lists 74500 CMOS series components.

1% METAL OXIDE FILM RESISTORS

Table with columns: Part, Price, Description. Lists 1% metal oxide film resistor specifications.

5% WIREWOUND RES. RESISTORS

Table with columns: Part, Price, Description. Lists 5% wirewound resistor specifications.

DISC CAPACITORS

Table with columns: Part, Price, Description. Lists disc capacitor specifications.

TRANSFORMERS

Table with columns: Part, Price, Description. Lists transformer specifications.

TRANSFORMERS

Table with columns: Part, Price, Description. Lists transformer specifications.

4000 CMOS

Table with columns: Part, Price, Description. Lists 4000 CMOS series components.

7400 CMOS

Table with columns: Part, Price, Description. Lists 7400 CMOS series components.

74500 TTL

Table with columns: Part, Price, Description. Lists 74500 TTL series components.

74500 CMOS

Table with columns: Part, Price, Description. Lists 74500 CMOS series components.

1% METAL OXIDE FILM RESISTORS

Table with columns: Part, Price, Description. Lists 1% metal oxide film resistor specifications.

5% WIREWOUND RES. RESISTORS

Table with columns: Part, Price, Description. Lists 5% wirewound resistor specifications.

DISC CAPACITORS

Table with columns: Part, Price, Description. Lists disc capacitor specifications.

TRANSFORMERS

Table with columns: Part, Price, Description. Lists transformer specifications.

TRANSFORMERS

Table with columns: Part, Price, Description. Lists transformer specifications.

4000 CMOS

Table with columns: Part, Price, Description. Lists 4000 CMOS series components.

7400 CMOS

Table with columns: Part, Price, Description. Lists 7400 CMOS series components.

74500 TTL

Table with columns: Part, Price, Description. Lists 74500 TTL series components.

74500 CMOS

Table with columns: Part, Price, Description. Lists 74500 CMOS series components.

NEC MEMORY CHIPS

Table with columns: Part, Price, Description. Lists NEC memory chip specifications.

NEC MICROPROCESSOR CHIPS

Table with columns: Part, Price, Description. Lists NEC microprocessor chip specifications.

SILICON TRANSISTORS

Table with columns: Part, Price, Description. Lists silicon transistor specifications.

1 AMP SILICON RECTIFIERS

Table with columns: Part, Price, Description. Lists 1 amp silicon rectifier specifications.

5% CARBON FILM RESISTORS

Table with columns: Part, Price, Description. Lists 5% carbon film resistor specifications.

NEC MEMORY CHIPS

Table with columns: Part, Price, Description. Lists NEC memory chip specifications.

NEC MICROPROCESSOR CHIPS

Table with columns: Part, Price, Description. Lists NEC microprocessor chip specifications.

SILICON TRANSISTORS

Table with columns: Part, Price, Description. Lists silicon transistor specifications.

1 AMP SILICON RECTIFIERS

Table with columns: Part, Price, Description. Lists 1 amp silicon rectifier specifications.

5% CARBON FILM RESISTORS

Table with columns: Part, Price, Description. Lists 5% carbon film resistor specifications.

NEC MEMORY CHIPS

Table with columns: Part, Price, Description. Lists NEC memory chip specifications.

NEC MICROPROCESSOR CHIPS

Table with columns: Part, Price, Description. Lists NEC microprocessor chip specifications.

SILICON TRANSISTORS

Table with columns: Part, Price, Description. Lists silicon transistor specifications.

1 AMP SILICON RECTIFIERS

Table with columns: Part, Price, Description. Lists 1 amp silicon rectifier specifications.

5% CARBON FILM RESISTORS

Table with columns: Part, Price, Description. Lists 5% carbon film resistor specifications.

NEC MEMORY CHIPS

Table with columns: Part, Price, Description. Lists NEC memory chip specifications.

NEC MICROPROCESSOR CHIPS

Table with columns: Part, Price, Description. Lists NEC microprocessor chip specifications.

SILICON TRANSISTORS

Table with columns: Part, Price, Description. Lists silicon transistor specifications.

1 AMP SILICON RECTIFIERS

Table with columns: Part, Price, Description. Lists 1 amp silicon rectifier specifications.

5% CARBON FILM RESISTORS

Table with columns: Part, Price, Description. Lists 5% carbon film resistor specifications.

NEC MEMORY CHIPS

Table with columns: Part, Price, Description. Lists NEC memory chip specifications.

NEC MICROPROCESSOR CHIPS

Table with columns: Part, Price, Description. Lists NEC microprocessor chip specifications.

SILICON TRANSISTORS

Table with columns: Part, Price, Description. Lists silicon transistor specifications.

1 AMP SILICON RECTIFIERS

Table with columns: Part, Price, Description. Lists 1 amp silicon rectifier specifications.

5% CARBON FILM RESISTORS

Table with columns: Part, Price, Description. Lists 5% carbon film resistor specifications.

NEC MEMORY CHIPS

Table with columns: Part, Price, Description. Lists NEC memory chip specifications.

NEC MICROPROCESSOR CHIPS

Table with columns: Part, Price, Description. Lists NEC microprocessor chip specifications.

SILICON TRANSISTORS

Table with columns: Part, Price, Description. Lists silicon transistor specifications.

1 AMP SILICON RECTIFIERS

Table with columns: Part, Price, Description. Lists 1 amp silicon rectifier specifications.

5% CARBON FILM RESISTORS

Table with columns: Part, Price, Description. Lists 5% carbon film resistor specifications.

NEC MEMORY CHIPS

Table with columns: Part, Price, Description. Lists NEC memory chip specifications.

NEC MICROPROCESSOR CHIPS

Table with columns: Part, Price, Description. Lists NEC microprocessor chip specifications.

SILICON TRANSISTORS

Table with columns: Part, Price, Description. Lists silicon transistor specifications.

1 AMP SILICON RECTIFIERS

Table with columns: Part, Price, Description. Lists 1 amp silicon rectifier specifications.

5% CARBON FILM RESISTORS

Table with columns: Part, Price, Description. Lists 5% carbon film resistor specifications.

The Dig. Key volume discount and service charges are simple to apply. Most items sold by Dig. Key may be returned for a volume discount. Items that are not discountable are identified by the suffix 'ND' following the part number. After writing your order, total all of the discountable items and apply the appropriate discount. To this subtotal, add the non-discountable items. Then add the service charges. We pay shipping and insurance to addresses in the U.S.A., Canada and Mexico when. Check or money order accompanies order. Dig. Key only ships orders with the comment 'L.S. Alaska, Hawaii, Canada and Mexico'.

WHEN ORDERING BY PHONE, CALL 1 800 344-4539 (AK, Dig. Key 218-681-6674). We mail SEND YOUR ORDER TO: DIGI KEY, P.O. Box 677, Thief River Falls, MN 56701. You may pay by check, money order, Master Charge, VISA or C.O.D. with 6% GUARANTEE. Any parts or products purchased from Dig. Key that prove to be defective will be replaced or refunded at no charge. All returned items must be accompanied by a copy of your invoice. PRICES SUBJECT TO CHANGE WITHOUT NOTICE.

SERVICE CHARGES VOLUME DISCOUNT

Table showing service charges and volume discount percentages for different order amounts.

CIRCLE 82 ON FREE INFORMATION CARD

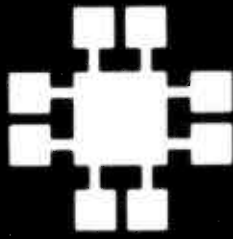

JDR Microdevices®

Complete customer satisfaction...superior service...friendly, knowledgeable personnel
quality merchandise...providing the best values in leading edge technology.

PROMETHEUS 2400 BAUD MODEM \$129⁹⁵ NEW LOW PRICE!

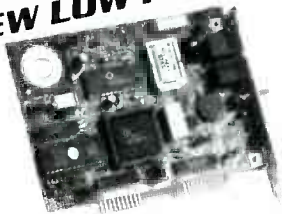

IT'S TIME TO TRADE UP NOW THAT JDR BREAKS THE PRICE BARRIER ON 2400 BAUD MODEMS

- AUTO DIAL ANSWER
- SELF TEST ON POWER-UP
- TOUCHTONE OR PULSE DIALING
- HAYES & BELL SYSTEMS COMPATIBLE
- FULL OR HALF DUPLEX
- MIRROR II COMMUNICATIONS SOFTWARE INCLUDED

MCT-241	
MCT-121 1200 BAUD 1/2 CARD	\$ 69.95
EXTERNAL MODEMS	
MCT-12E 1200 BAUD	\$ 99.95
MCT-24E 2400 BAUD	\$169.95

COMPUTER CASES

ATTRACTIVE, STURDY STEEL CASES FIT THE POPULAR SIZED MOTHERBOARDS AND INCLUDE SPEAKERS, FACEPLATES, EXPANSION SLOTS, FRONT PANEL KEYLOCKS, LED INDICATORS AND ALL NECESSARY HARDWARE



XT STYLE FLIP-TOP	\$34.95
XT STYLE SLIDE-TOP	\$39.95
AT STYLE SLIDE-TOP	\$89.95
JR. AT STYLE FLIP-TOP	\$149.95
■ INCLUDES 150 WATT POWER SUPPLY	

POWER SUPPLIES

FOR IBM XT COMPATIBLE \$59.95

- UL APP., 135 WATTS
- +5V.15A, +12V 4.2A
- 5V. 5A, 12V. 5A

PS-135
PS-150 150W MODEL \$69.95

FOR IBM AT COMPATIBLE \$89.95

- 200 WATTS
- 5V 22A, +12V 8A
- 5V. 5A, +12V. 5A

PS-200

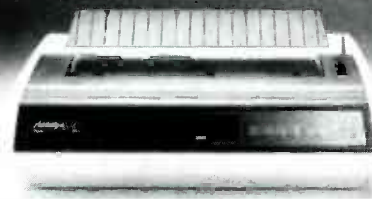

DIABLO PRINTER \$279⁹⁵

- LETTER QUALITY AT 20 CPS, 132 COLS
- 10, 12, 15 PITCH & PROPORTIONAL SPACING
- SERIAL & PARALLEL INTERFACE
- AUTO PAPER LOAD, FRICTION FEED
- FULL XEROX WARRANTY



CENTRONICS LASER \$1195 PRINTER

NEAR TYPESET QUALITY
AFFORDABLE AT LAST

- 8 PAGES PER MINUTE ■ 300 DPI RESOLUTION!
- 1 YEAR WARRANTY ■ CHOICE OF EMULATION BOARDS

MULTI-PRINTER EMULATION BOARD:
EPSON FX-80 EMULATION—NOTHING ELSE REQUIRED
IBM PC GRAPHICS, PROPRINTER & DIABLO 630
EMULATION REQUIRES ADDITIONAL FONT CARD

HP LJ+ EMULATION BOARD:
HP LASERJET EMULATION—3 RESIDENT FONTS &
2 PITCHES ADDITIONAL FONT CARD AVAILABLE

1.5MB RAM CARD	\$139.95
EXTRA FONT CARDS	\$199.95
TONER CARTRIDGES	\$59.95
PFS FIRST PUBLISHER	\$99.95

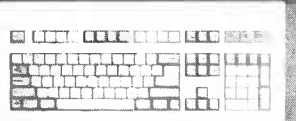

IBM COMPATIBLE KEYBOARDS

FULL ONE YEAR WARRANTY

IBM ENHANCED STYLE LAYOUT \$79.95

- AUTOSENSE FOR XT OR AT COMPATIBLES
- LED INDICATORS ■ AUTO REPEAT FEATURE
- SEPARATE CURSOR PAD

MCT-5339
IBM AT STYLE LAYOUT \$59.95

- SOFTWARE AUTOSENSE FOR XT OR AT COMPATIBLES
- LED INDICATORS ■ AUTO REPEAT FEATURE

MCT-5060
MAXI-SWITCH KEYBOARDS \$84.95

- STANDARD ENHANCED KEYBOARD LAYOUT
- TACTILE FEEDBACK
- LIGHTED NUM. CAPS. AND SCROLL LOCK
- NUMERIC & CURSOR KEYPADS, 12" F" KEYS

MAX-5339
MAX-5060 MAXI-SWITCH, AT STYLE \$64.95

VGA COMPATIBLE PACKAGE \$649⁰⁰

MONITOR
& CARD
TOGETHER



- 800 X 560 MAXIMUM RESOLUTION
- 640 X 480 IN 16 COLORS
- 320 X 200 IN 256 COLORS
- IBM STYLE ANALOG MONITOR
- FULLY VGA, EGA, CGA, HERCULES & MONOCHROME COMPATIBLE



NEC MULTISYNC \$599.95

- ORIGINAL CGA EGA VGA COMPATIBLE MONITOR
- AUTO FREQUENCY ADJUSTMENT
- RESOLUTION AS HIGH AS 800 X 560

CASPER EGA \$399.95

- 15.75 21.85 KHz SCANNING FREQUENCIES
- 640 X 200 350 RESOLUTION ■ 31 MM DOT PITCH
- 14" BLACK MATRIX SCREEN ■ 16 COLORS

CASPER RGB \$279.95

- COLOR GREEN AMBER SWITCH ■ 39MM DOT PITCH
- 640 X 240 RESOLUTION ■ 14" NON-GLARE SCREEN
- RGB-IBM COMPATIBLE ■ CABLE INCLUDED

SAKATA MONOCHROME \$69.95

- IBM COMPATIBLE TTL INPUT
- 12" NON-GLARE SCREEN
- CABLE FOR IBM PC INCLUDED

SAMSUNG MONOCHROME MONITOR \$129.95

MONITOR STANDS

MODEL MS-100 \$12.95

- TILTS AND SWIVELS
- STURDY PLASTIC CONSTRUCTION

MODEL MS-200 \$39.95

- TILTS AND SWIVELS ■ BUILT-IN SURGE SUPPRESSOR
- INDEPENDENTLY CONTROLS UP TO 5 AC OUTLETS

LOGITECH MOUSE \$79⁹⁵



PC MAGAZINE'S EDITORS CHOICE
ALL MODELS HAVE SERIAL SUPPORT (COM1 COM2), 200
D.P.I. RESOLUTION, LOTUS 1-2-3 SHELL, SELF-INSTALLING
SOFTWARE AND "POINT EDITOR"

SERIAL MOUSE W/PC PAINTBRUSH \$99.95

BUS MOUSE W/PC PAINTBRUSH \$99.95

BUS MOUSE W/PC PAINTBRUSH/CAD \$149.95

3.5" FLOPPY DISK DRIVE \$149⁹⁵

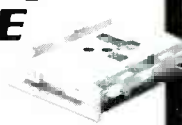

1.44 MB 3 1/2" DRIVE

- ULTRA HIGH DENSITY
- ALSO WORKS WITH 720K DISKS

FDD-1.44 x BLACK FACEPLATE \$149.95

FDD-1.44 x BEIGE FACEPLATE \$149.95

720K 3 1/2" FLOPPY DRIVE \$129.95

FDD-3.5 x (FORXT)

FDD-3.5 x (FORATI)

Seagate

NEW!
FAST 40MB DRIVE
\$529.00

THE NEW ST-251-1 DRIVE IS 30% FASTER WITH AN AVERAGE ACCESS TIME OF 28 MS. EASY TO INSTALL HALF-HEIGHT DRIVE.

ST-251-1
WITH MCT-HDC CONTROLLER \$569.00
WITH MCT-ATFH CONTROLLER \$639.00

1/2 HEIGHT DRIVES

20 MB, 65 MS, ST-225 \$225.00
WITH MCT-HDC CONTROLLER \$269.00
WITH MCT-ATFH CONTROLLER \$339.00

30 MB RLL, 65 MS, ST-238 \$249.00
WITH MCT-RLL CONTROLLER \$299.00
WITH MCT-ATFH-RLL CONTROLLER \$389.00

40 MB, 40 MS, ST-251 \$429.00
WITH MCT-HDC CONTROLLER \$469.00
WITH MCT-ATFH CONTROLLER \$539.00

60 MB RLL, 40 MS, ST-277 \$499.00
WITH MCT-RLL CONTROLLER \$549.00
WITH MCT-ATFH CONTROLLER \$639.00

FULL HEIGHT DRIVES

30 MB, 40 MS ST-4038 \$559.00
80 MB, 28 MS ST-4096 \$895.00

INTERFACE CARDS FROM MODULAR CIRCUIT TECHNOLOGY DISPLAY ADAPTORS

MONOCHROME GRAPHICS CARD \$59.95
TRUE HERCULES COMPATIBILITY SUPPORTS LOTUS 123
■ PARALLEL PRINTER PORT CONFIGURES AS CPT1 OR LPT2 ■ USES VLSI CHIPS TO ENSURE RELIABILITY
MCT-MGP

ENHANCED GRAPHICS ADAPTOR \$149.95
100% IBM COMPATIBLE. PASSES IBM EGA DIAGNOSTICS
■ 256K OF VIDEO RAM ALLOWS 640 X 350 IN 16 OF 64 COLORS ■ COMPATIBLE WITH COLOR AND MONOCHROME ADAPTORS
MCT-EGA

COLOR GRAPHICS ADAPTOR \$49.95
COMPATIBLE WITH IBM GRAPHICS STANDARDS
■ SUPPORTS RGB, COLOR & COMPOSITE MONOCHROME
■ 640 320 X 200 RESOLUTION. LIGHT PEN INTERFACE
MCT-CG

MULTIFUNCTION CARDS

MONOGRAPHICS MULTI 110 \$119.75
TOTAL SYSTEM CONTROL FROM A SINGLE SLOT!
■ CTRL 2 FLOPPY S, SERIAL, PARALLEL, GAME PORT, CLOCK CAL ■ RUN COLOR GRAPHICS SOFTWARE ON A MONOCHROME MONITOR
MCT-MGM10

MULTI 110 FLOPPY CONTROLLER \$79.95
A PERFECT COMPANION FOR OUR MOTHERBOARDS
■ SUPPORTS UP TO 2 360K FLOPPIES, 720K WITH DOS 3.2
■ SERIAL, PARALLEL, GAME PORT, CLOCK CALENDAR
MCT-M10
M10-SERIAL—2ND SERIAL PORT \$15.95

MULTI 110 CARD \$59.95
USE WITH MCT-FH FOR A MINIMUM OF SLOTS USED
■ SERIAL PORT, CLOCK CALENDAR WITH BATTERY BACK UP ■ PARALLEL PRINTER PORT ADDRESSABLE AS LPT1 OR LPT2
MCT-I0

AT MULTIFUNCTION CARD \$139.95
ADDS UP TO 3MB OF RAM TO YOUR AT
■ USER EXPANDABLE TO 1.5 MB, OR 3 MB WITH OPTIONAL PIGGYBACK BOARD (0 K INSTALLED) ■ INCLUDES SERIAL AND PARALLEL PORT
MCT-ATMF-MC PIGGYBACK BOARD \$29.95
ATMF SERIAL-2ND SERIAL PORT \$24.95

AT MULTI 110 CARD \$59.95
USE WITH MCT-ATFH FOR MINIMUM OF SLOTS USED
■ SERIAL, PARALLEL AND GAME PORTS ■ USES 16-150 SERIAL SUPPORT CHIPS FOR HIGH SPEED OPS
MCT-AT10
AT10-SERIAL—2ND SERIAL PORT \$24.95

MEMORY CARDS

576K RAM CARD \$59.95
A CONTIGUOUS MEMORY SOLUTION IN A SHORT SLOT
■ USER SELECTABLE CONFIGURATION UP TO 576K
■ USES 64K & 256K RAM CHIPS (ZERO K INSTALLED)
MCT-RAM

EXPANDED MEMORY CARD \$129.95
2 MB OF LOTUS INTEL MICROSOFT COMPATIBLE MEMORY FOR AN XT ■ CONFORMS TO LOTUS INTEL EMS ■ USER EXPANDABLE TO 2 MB ■ CAN BE USED AS EXPANDED OR CONVENTIONAL MEMORY, RAMDISK AND SPOOLER
MCT-EMS
MCT-ATEMS AT COMPATIBLE VERSION \$139.95

DRIVE CONTROLLERS

FLOPPY DISK CONTROLLER \$29.95
QUALITY DESIGN FOR SINGLE SLOT CONTROL OF 4 FLOPPY S ■ INTERFACES UP TO 4 FDD S TO AN IBM PC OR COMPATIBLE ■ SUPPORTS BOTH DS DD AND DS QD WITH DOS 3.2
MCT-FDC

1.2 MB FLOPPY CONTROLLER \$69.95
ADD VERSATILITY AND CAPACITY TO YOUR XT
■ SUPPORTS 2 DRIVES, BOTH MAY BE 360K OR 1.2 MB
■ ALLOWS DATA TO FLOW FREELY FROM XT S TO AT S
MCT-FDC-1.2

FLOPPY/HARD CONTROLLER \$139.95
XT SYSTEM STARVED FOR SLOTS? THIS CARD FREES ONE UP ■ INTERFACES UP TO 2 FDD S & 2 HDD S, CABLING FOR 2 FDD 1 HDD ■ SUPPORTS BOTH DS DD & DS QD WITH DOS 3.2
MCT-FH

ATFH CONTROLLER \$149.95
FLOPPY HARD DISK CONTROL IN A TRUE AT DESIGN
■ SUPPORTS UP TO 2 360K 720K 1.2MB FDD S AS WELL AS 2 HDD S USING STANDARD CONTROL TABLES
MCT-ATFH

RLL DISK CONTROLLER \$199.95
IMPROVE SPEED AND STORAGE OF YOUR AT COMPATIBLE ■ SUPPORTS UP TO 2 RLL HARD DISCS AND 2 FLOPPY DRIVES ■ SUPPORTS 360 720 1.2 MB FLOPPIES IN 5.25" & 3.5"
MCT-ATFH-RLL

TEAC DISK DRIVE

360K 5 1/4" DRIVE \$99.95
■ RELIABLE DIRECT DRIVE MOTOR
■ DOUBLE-SIDED/DOUBLE-DENSITY FD-55B

1/2 HEIGHT FLOPPY DISK DRIVES
5 1/4" TEAC FD-55G DS/HD 1.2M \$129.95
5 1/4" FUJITSU M2551A DS/DD 360K \$89.95
5 1/4" FUJITSU M2553K DS/HD 1.2M \$119.95
5 1/4" DS DD 360K \$69.95
5 1/4" DS HD 1.2M \$109.95
3 1/2" MITSUBISHI DS/DD (AT OR XT) \$129.95



ARCHIVE XL TAPE BACK-UP \$369.95

BACK UP 40 MB IN 40 MINUTES!
■ EASY-TO-USE MENU DRIVEN SOFTWARE
■ USES STANDARD QIC DATA FORMAT
■ FULL & INCREMENTAL BACK-UP
■ PARTIAL & FULL RESTORE

AR 5240 XT —FOR XT S & AT S
AR 5540 AT —AT S ONLY 2X FASTER
TAPE NOT INCLUDED
TAPE CARTRIDGE—40 MB \$24.95



20MB HARD DISK ON A CARD \$349

■ SAVES SPACE AND REDUCES POWER CONSUMPTION
■ IDEAL FOR PC S WITH FULL HEIGHT FLOPPIES
■ LEAVES ROOM FOR A HALF LENGTH CARD IN ADJACENT SLOT



“ JUST A NOTE TO LET YOU KNOW THAT MY SALESPERSON, HELEN MORSE, AT YOUR COMPANY HAS BEEN VERY HELPFUL AND COURTEOUS. THIS IS A PLEASANT CHANGE FROM MOST TELEPHONE SALESPEOPLE I DEAL WITH. PLEASE PASS MY THANKS TO HELEN. I PLAN ON DOING FREQUENT BUSINESS WITH JDR AS MY NEW COMPANY, ODEM INC. GETS GOING, AND HELEN'S ATTITUDE AND HELPFULNESS ARE A MAJOR REASON WHY I LIKE DOING BUSINESS WITH YOU. ”

R.C.K. BENSLEM, PA

BARGAIN HUNTER'S CORNER
720K FLOPPY DISK DRIVE BY MITSUBISHI
■ 5 1/4" HALF-HEIGHT
■ 96 T.P.I.
■ 100% IBM COMPATIBLE
■ DOUBLE-SIDED/QUAD DENSITY
ONLY \$69.95
SPECIAL ENDS 8/31/88

intel



INBOARD 386/PC \$895.00

UPGRADE YOUR XT TO A 386 FOR LESS THAN \$1000
■ 16 MHZ PROCESSOR REPLACES 8088 ■ 1 MB INSTALLED ■ EXPAND TO 3MB WITH PIGGYBACK CARD
■ 5 YR WARRANTY

INBOARD 386 AT \$1199.95
ABOVE BOARD PS 286 \$399.95
ABOVE BOARD 286 \$369.95

JDR MICRODEVICES, 110 KNOWLES DRIVE, LOS GATOS, CA 95030
LOCAL (408) 866-6200 FAX (408) 378-8927 TELEX 171-110

ORDER TOLL FREE 800-538-5000

COPYRIGHT 1988 JDR MICRODEVICES

CONTINENTAL U.S. AND CANADA



CIRCLE 180 ON FREE INFORMATION CARD

www.americanradiohistory.com

BUILD YOUR OWN SYSTEM

**OVER 20,000 JDR SYSTEMS
HAVE ALREADY BEEN BUILT.
EASY TO ASSEMBLE IN JUST 2
HOURS WITH A SCREWDRIVER.
SAVE MONEY AND LEARN
ABOUT YOUR COMPUTER AT
THE SAME TIME.**

**10 MHZ XT
COMPATIBLE
\$656⁵⁰**

- INCLUDES SERIAL PORT 2 PARALLEL PORTS, CLOCK CALENDAR AND GAME ADAPTOR, RUNS COLOR GRAPHICS ON A MONOCHROME MONITOR
- MOTHERBOARD
- 256K RAM MEMORY
- 135 WATT POWER SUPPLY
- FLIP-TOP CASE
- AT STYLE KEYBOARD
- 360K FLOPPY DRIVE
- MONOGRAPHICS I/O CARD
- MONOCHROME MONITOR

**12 MHZ AT
COMPATIBLE
\$1101⁷⁰**

- 12 MHZ BABY AT MOTHERBOARD
- 256K RAM MEMORY
- MINI-AT CASE W POWER SUPPLY
- AT STYLE KEYBOARD
- 1 2 MB FLOPPY DRIVE
- FLOPPY HARD DRIVE CONTROLLER
- MONOCHROME MONITOR
- GRAPHICS ADAPTOR

**16 MHZ
1 MB 386
\$2298⁶⁵**

- MYLEX 386 MOTHERBOARD
- 1 MB RAM ON BOARD
- 200 WATT POWER SUPPLY
- AT STYLE CASE
- ENHANCED AT STYLE KEYBOARD
- 1 2 MB FLOPPY DRIVE
- AT FLOPPY HARD CONTROLLER
- MONOCHROME MONITOR
- MONOGRAPHICS CARD

**VIDEO
INSTRUCTIONS
\$4⁹⁵
WITH KIT PURCHASE
IT'S A JDR
EXCLUSIVE!
EASY TO FOLLOW
20 MINUTE VHS
TAPE SHOWS YOU
STEP-BY-STEP
HOW TO BUILD
AN XT COMPATIBLE
SYSTEM.
WITHOUT KIT
\$19.95**



MOTHERBOARDS

TURBO 4.77/8 MHZ

\$99.95

- 4.77 OR 8 MHZ OPERATION WITH 8088 2 & OPTIONAL 8087-2 CO-PROCESSOR
- FRONT PANEL LED SPEED INDICATOR AND RESET SWITCH SET SUPPORTED
- CHOICE OF NORMAL TURBO MODE OR SOFTWARE SELECT PROCESSOR SPEED

MCT-TURBO

MCT-XTMB STANDARD MOTHERBOARD \$87.95

12 MHZ MINI 80286

\$399.95

- 6 MHZ, 10 MHZ (0 1 WAIT STATE), 12 MHZ (1 WAIT STATE)
- USES ZYMOS ASIC S FOR LESS CHIPS, GREATER RELIABILITY
- SUPPORTS 256K-1024K MEMORY
- RE-CHARGEABLE HIGH CAPACITY NI-CAD BATTERY
- 6 16-BIT SLOTS, 2 8-BIT SLOTS
- MOUNTS IN STANDARD XT CASE

MCT-BATMB-12

MCT-BATMB 6/10 MHZ MINI 80286 BOARD \$389.95

80286 6/8 MHZ

\$379.95

- 8 SLOT (2 EIGHT BIT, 6 SIXTEEN BIT) AT MOTHERBOARD
- HARDWARE SELECTION OF 6 OR 8 MHZ
- 1 WAIT STATE
- KEYLOCK SUPPORTED, RESET SWITCH, FRONT PANEL LED INDICATOR
- SOCKETS FOR 1 MB OF RAM AND 80287
- BATTERY BACKED CLOCK

MCT-ATMB

16 MHZ MYLEX 386

\$1649.00

- 1 MB RAM ON BOARD
- 8 SLOTS, 2 8-BIT, 6 16-BIT
- SUPPORTS 80287 MATH CO-PROCESSOR
- SUPPORTS 80387 W/ADAPTOR
- 64 KB CACHE FOR NEAR 0 WAIT STATE
- USES AMI BIOS

MCT-386 MB

MCT-386 MB-4 4 MB MEMORY INSTALLED \$2649.00

MCT-386 MB-MCB MATH CO-PROCESSOR ADAPTOR BOARD \$149.00

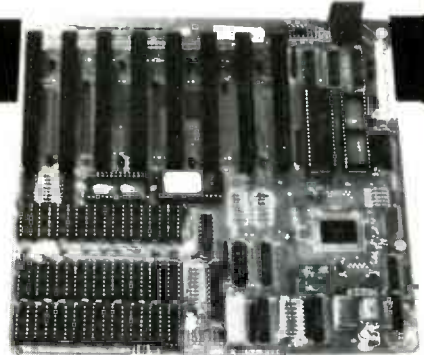

**10 MHZ SINGLE CHIP XT
\$129⁹⁵**

- SINGLE CHIP USES LESS POWER, IMPROVES RELIABILITY
- KEY SELECTABLE SPEED, 4.77 MHZ OR 10 MHZ
- 2 3 TIMES FASTER THAN A STANDARD
- RESET SWITCH, KEYLOCK AND SPEED POWER INDICATORS SUPPORTED

MCT-TURBO-10

DEVELOPMENT TOOLS

**EPROM
PROGRAMMER
\$129⁹⁵**

- PROGRAMS 27XX & 27XXX EPROMS UP TO 27512
- SUPPORTS VARIOUS PROGRAMMING FORMATS AND VOLTAGES
- SPLIT OR COMBINE CONTENTS OF SEVERAL EPROMS OF DIFFERENT SIZES
- READ, WRITE, COPY, ERASE CHECK AND VERIFY
- SOFTWARE FOR HEX AND INTEL HEX FORMATS

MCT-EPROM

MCT-EPROM-4 4 GANG PROGRAMMER \$189.00

MCT-EPROM-10 10 GANG PROGRAMMER \$299.95

MCT-PAL PAL PROGRAMMER \$269.95

MCT-MP PROCESSOR PROG. \$199.95

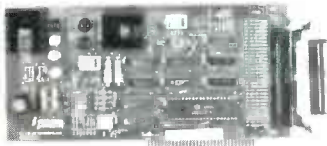

- 1 YEAR WARRANTY ON MCT PRODUCTS
- 30 DAY MONEY BACK GUARANTEE
- TOLL-FREE TECHNICAL SUPPORT
- NEXT DAY AIR SHIP AVAILABLE

JDR Microdevices®

JDR MICRODEVICES, 110 KNOWLES DRIVE, LOS GATOS, CA 95030
LOCAL (408) 866-6200 FAX (408) 378-8927 TELEX 171-110



ORDER TOLL FREE 800-538-5000

COPYRIGHT 1988 JDR MICRODEVICES

CONTINENTAL U.S. AND CANADA

CIRCLE 101 ON FREE INFORMATION CARD
www.americanradiohistory.com

Radio Shack Parts Place

HOLIDAY VALUES FOR BUILDERS AND FIXERS!

Save With "Hotline" Order Service

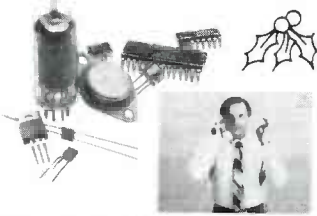

Your Radio Shack store manager can special-order a wide variety of parts and accessories from the Radio Shack warehouse—tubes, ICs, phono styli, diodes, crystals, Sams PHOTOFACTS® and more. No postage charges, no minimum order. One-week service on most items.

Get Your Novice Ham License

19⁹⁵

Take Advantage of the New Voice Privileges

Radio Shack's Novice Exam Study Package will help you pass the test. It includes two cassettes for self-paced Morse code learning plus practice questions and answers. Get on the air! #62-2402

Speech/Word Recognition IC



9⁹⁵

Understands Seven Commands

VCP200. Explore leading-edge technology—voice recognition! Recognizes spoken commands regardless of the person speaking—five motion commands and two on/off commands. Analog input—no external A-to-D conversion is required. 20-pin DIP with data. #276-1308

Harness the Power of the Sun

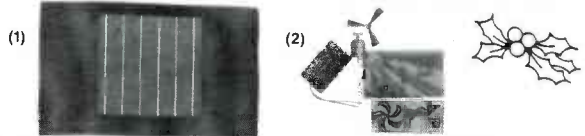

- (1) **NEW! Flexible Solar Cell.** High-tech breakthrough! This amorphous silicon alloy-on-stainless steel cell is efficient and rugged. Produces up to 1.2 VDC at 65 mA. 3 1/4 x 17/8". #276-138 5.95
- (2) **Solar Energy Project Set.** Just the thing for models and school science class. Includes solar cell prewired to DC motor, color wheels, propeller, informative project booklet. #277-1201 9.95

Safe Handling for Sensitive ICs

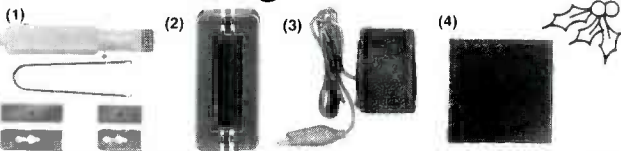

- (1) **IC Inserter/Extractor Set.** #276-1581 6.95
- (2) **IC Pin Straightener.** #276-1594 2.99
- (3) **Static-Draining Wrist Strap.** #276-2399 2.79
- (4) **Conductive Foam Mat.** 5 x 5". #276-2400 89¢

AC Power Controller/Protector



49⁹⁵

Switches Up to Four Devices Automatically

Allows one component to switch up to four other devices. Also protects against damaging power-line spikes. Use with a remote-control VCR, TV or stereo to switch on/off entire audio/video system. Or, use with a VCR or clock radio to switch other components automatically at preset times. Has one sensed, four switched and one unswitched outlets, heavy-duty spike protector, noise filter, circuit breaker. UL listed AC. #61-2781

Solder Anywhere



29⁹⁵ Super Gift!

Our gas-powered iron provides up to 60 minutes of continuous soldering. Refills in seconds like a butane cigarette lighter. Adjustable temperature. #64-2160

Small Bargains



- (1) **NEW! Small-Value Ceramic Capacitors.** #272-806 Pkg. of 50/2.99
- (2) **NEW! 12V Microlamps.** T-1 size, with leads. #272-1092 Pkg. of 2/1.39
- (3) **Thermistor.** #271-110 1.99
- (4) **NEW! Micro-Hook 18 1/2" Test Leads.** Banana plugs. #278-018 Pair/3.49

Gold-Plated Plugs

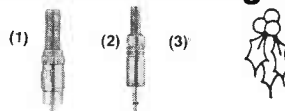

Connect With the Best!

- (1) **Phono Plug.** #274-850 2.49
- (2) **2-Conductor 1/4" Phone Plug.** #274-855 3.49
- 3-Cond. 1/4" Plug.** #274-856 3.99
- (3) **2-Cond. 1/8" Plug.** #274-857 2.79
- 3-Cond. 1/8" Plug.** #274-858 3.49

Computer Helpers



- (1) **Snap-Together Toroid Choke Cores.** Easy-to-install RFI/EMI/line-noise filters. #273-104 Pkg. of 2/6.95
- (2) **"Business Machine" Cord.** CEE-style connector. 6 ft. #278-1257 3.99
- (3) **RS-232 Spike Protector.** Installs in-line. D-sub 25. #276-1402 16.95

28-Range FET VOM

49⁹⁵

10-Megohm FET Input—Works Like A Solid-State VTVM
Easy-to-Read 5" Meter



Our best analog multimeter! Features single-knob range control, audible continuity tester and handy 10-amp DC range. Includes probes and illustrated manual. Batteries extra. #22-220

Solderless Breadboard

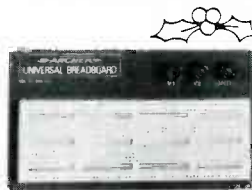

19⁹⁵

Shop Early!
A Great Gift
For Students
And Hobbyists

Our best! This 2 1/4 x 6 1/2" b-board is mounted on a "stay-put" steel base with rubber feet. Has 240 plug-in points which accept DIPs, discretes and up to 22-gauge wire. Three binding posts. #276-169

Logic Probe and Pulser

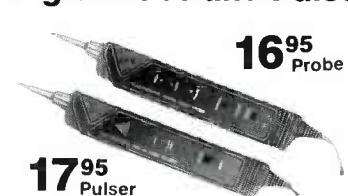

16⁹⁵ Probe

17⁹⁵ Pulser

Logic Probe. Color-coded LEDs and tone outputs indicate logic states. For TTL, LS and CMOS. #22-303

Pulser. Teammate for the probe. Produces a single 5 µs pulse or a continuous pulse train. #22-304

Over 1000 items in stock! Binding Posts, Books, Breadboards, Buzzers, Capacitors, Chokes, Clips, Coax, Connectors, Fuses, Hardware, ICs, Jacks, Knobs, Lamps, Multitesters, PC Boards, Plugs, Rectifiers, Resistors, Switches, Tools, Transformers, Transistors, Wire, Zeners, More!

Prices apply at participating Radio Shack stores and dealers

Radio Shack
The Technology Store™

A DIVISION OF TANDY CORPORATION

CIRCLE 78 ON FREE INFORMATION CARD

www.americanradiohistory.com

What's New at AMERICAN DESIGN COMPONENTS?

We warehouse 60,000 items at American Design Components—expensive, often hard-to-find components for sale at a fraction of their original cost!

You'll find every part you need—either brand new or removed from equipment (RFE) in excellent condition. But quantities are limited. Order from this ad, or visit our retail showroom and find exactly what you need from the thousands of items on display.

OPEN MON.—SAT., 9–5

THERE'S NO RISK!

With our 90-day warranty, any purchase can be returned for any reason for full credit or refund.

COMMODORE COMPUTERS...



PLUS 4 — *(Cust. Returns — Tested Good!)*
Built-in software incl.: a word processor, spreadsheet, graphics, & a filing system. Comes complete w/power supply & instruction manual.
Item #19202 **\$49.95**

VIC 20 — *(Cust. Returns — As Is!)*
No guarantee. (Power supply not incl.)
Item #18770 **\$29.95**

COMMODORE 8050 Dual Disk Drive Unit...



The 8050 uses 2 full-height, 100 TPI single-sided disk drives, ea. w/storage cap. of 533,248 bytes. Ea. 8050 diskette has 77 tracks & is read/write compatible w/the 8250 disk drive. Complete w/built-in power supply. Power req.: 115VAC/60Hz. (manuals incl.) Dim.: 13 3/4" W x 13 3/4" D x 6" H.
Item #19313 **New — \$89.95**

ADAM COMPUTER

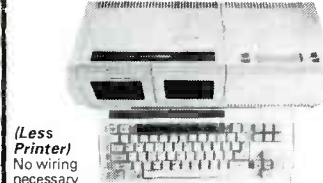

(Less Printer) No wiring necessary (just plug together). Incl: hook-up diagram; keyboard, 1 cassette digital data drive, 2 game controllers, power supply & 1 cassette. Capable of running CP/M, has built-in word processor.
Item #7410 **Complete — \$99.00**

ACCESSORIES... COLECOVISION to ADAM EXPANSION KIT

Just plugs into your ColecoVision. W/printer power supply & data drive (both incl.) you will have a working Adam computer. Adam keyboard, 1 Smart Basic cassette & hook-up diagram also incl. Item #9918 **\$59.50**

DATA DRIVE — Item #6641... **\$19.95**

PRINTER POWER SUPPLY — Item #6642... **\$14.95**

ASCII KEYBOARD — Item #6643... **\$19.95**

CONTROLLERS (Set of 4) — Item #7013... **\$9.95 RFE**

ADAM CASSETTES — Incl. Smart Basic, Buck Rogers & blank cassette. Item #7786 **\$19.95**

Baker's Dozen — **\$19.95**

DISK DRIVE POWER SUPPLY — Item #14603... **\$14.95**

ADAM DAISY PRINT WHEEL — Item #13305... **\$3.95**

5 1/4" FULL-HEIGHT HARD DISK DRIVES

40Mb (AT/XT Compat.)
High speed, 40 ms. access time. Quantum #0540
Item #17765 **New — \$379.00**

10Mb (ST412 Compat.)
Major manufacturers — *Get them while they last!*
Item #17199 **\$99.00 ea.**

115 CFM MUFFIN® FANS

 115VAC, 60Hz., 21W., 28A., 3100 RPM, 5-blade model, aluminum housing. Can be mounted for blowing or exhaust. Dimen: 4 1/16" sq. x 1 1/2" deep
NEW — Mfr: IMC
Item #1864 **\$9.95**

USED — Mfr: Centaur/Howard
Item #5345 **\$5.95**

27 CFM MINI FANS

 50/60Hz., 12W. Low noise level fans. Can be mounted for blowing or exhaust. **1" Thin** — Contains 9 plastic blades. Dimensions: 3 1/8" sq. x 1" deep. Mfr — Toshiba #U9201B
Item #10960 **\$7.95 RFE**

1" Standard — Contains 7 metal blades. Mfr — Rotron #SU2A1
Item #5970 **\$7.95 New**

Call or write with any other requirements...

5 1/4" FULL-HEIGHT DISK DRIVE (IBM® Compat.)

 **48 TPI, 40 Track, Double Side/Double Density**
Tandon #TM100-2 or equiv.
Item #7928 **\$79.00 New**
2 for \$150.00 New

12/24VDC MUFFIN® TYPE FAN 55/100CFM

 **1" THIN:** 5 plastic blades with feathered edges. 8W. Can be mounted for blowing or exhaust. Aluminum housing. Brushless, ball-bearing type. Mfr: Centaur, #CUDC24K-601
Item #8541 **New — \$19.95**

TTL MONITORS... HI-RES... (Open Frame)

 **12" — High Resolution**
12VDC, green phosphor. Sub-assemblies, CRT, board & transformer included. Comes with hook-up diagram.
Item #6811 **New — \$19.95**

15" Data Display/Monitor Kit
Alphanumeric & graphics display. Green phosphor. Input power req. 24VDC. Bandwidth: 22–72Khz. Consists of 2 sub-assemblies (monitor & board). Hook-up diagram incl. Wells Gardner #15V7025
Item #16171 **New — \$24.95**

3 1/2" MICROFLOPPY DISK DRIVE

 **1 Mb (unformatted), 135 TPI, 3 ms. access time.** Power requirements: +12, +5 volts. Removed from operational computers — **TESTED — LIKE NEW!**
Mfr — NEC, model FD1035
Item #17171 **\$79.00 ea.**
2 for \$150.00

5 1/4" 1.2Mb. HALF-HEIGHT FLOPPY DISK DRIVE

 **IBM® AT Compatible. 48/96 TPI, 1.2 Mb.** Double sided, high density; 160 tracks. Mfr — Panasonic #JU-475
Item #10005 **New — \$109.95**

INDOOR/OUTDOOR MULTI-PURPOSE SPEAKER 40W, 8 Ohm

 Ideal for use in siren and marine applications. 40 watts nominal input, 8 ohm impedance. Frequency range: 400–13,000. Extra heavy-duty plastic casing, weather-proof and weather resistant; swivel bracket. Dim.: 11" x 6 1/2" Mfr — HS-12SBP
Item #19617 **New — \$29.95**

...We carry a complete line of Computer & Game Accessories and Equipment!

ADJUSTABLE POWER SUPPLY 0–16VDC

 Input: 120VAC/60Hz., 6A. Output: variable, 0–16V, 16VDC max. @ 4.0A. UL approved; thermally protected. Has 'on/off' indicator light & front panel mtd. polarized jack. Perfect for use w/variable speed motors, fans, toys, etc. Dim.: 6 5/8" W x 3 3/8" H x 3 1/2" deep
Mfr — Black & Decker #9821
Item #19585 **New — \$14.95**

HIGH POWER SWITCHING POWER SUPPLIES

 DC Output: +5V @ 18A
-5V @ 2.5A
+12V @ 2.5A
Input: 115/230VAC, 50/60Hz. Dim.: 13" L x 4 1/2" W x 1 1/2" H
Mfr — Sola #39–139
Item #17210 **New — \$29.95**

 DC Output: +5V @ 8A
+12V @ 500 ma.
-12V @ 200 ma.
+24V @ 2.0A.
Input: 115/230VAC, 50/60Hz. Dimensions: 8 3/4" x 4 5/8" x 2" H.
Mfr — Power Systems #PS1547
Item #16585 **\$19.95**

RECORDING TAPE 7 1/2" Reel, 2400 ft.

 1/4 Mil. Bulk erased. Major mfrs.: Ampex, Scotch, etc. Item #6711.
15 reels for **\$9.95**

HIGH-RESOLUTION INSTRUMENTATION TAPE

 1/2" tape on 14" reels; 9200'/reel. Wide band, highly conductive tape, w/magnetic oxide surface (makes it ultrasmooth for chart-wave recording). Orig. used in gov't & other critical instrument applications. Standard hub size. Mfr — Scotch/Ampex #890/892
Item #17656 **\$8.95 ea.**
2 for \$16.00

MECHANICAL KEYBOARDS...

 **48-KEY — Timex Z81/1000**
Item #6712 **New — \$5.95**

75-KEY — Timex or Adam
For computer upgrade—
Item #7429 **New — \$5.95**

66-KEY — Commodore C-16
Item #9394 **New — \$5.95**

COPPER-CLAD PRINTED CIRCUIT BOARD (Double-Sided)

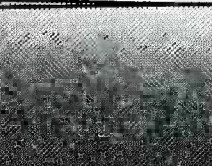
 Glass coated, epoxy laminated. 1 oz. Double sided, .022" thick. Dimensions: 24" L x 18.5" H
Item #13606
3 sheets / \$9.95

COMPUTER/GAME ADAPTERS...

 **COMMODORE 64**
DC Output: 5VDC @ 7.5W and 9VAC @ 6.7VA
Input: 117VAC, 50/60Hz.
Commodore #310157-02 (black)
Item #19315 **New — \$14.95**

COMMODORE C16

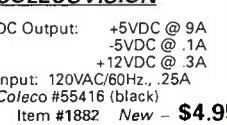
 DC Output: +5VDC @ 9A
-5VDC @ 1A
+12VDC @ 3A
Input: 120VAC/60Hz., 25A
Coleco #55416 (black)
Item #1882 **New — \$4.95**

COMMODORE C16
DC Output: 9.5V @ 1A.
Input: 115VAC, 50/60Hz.
Commodore #251539-01/02 (black)
Item #9393 **New — \$4.95**

Mail Order Electronics - Worldwide

ameco ELECTRONICS

Mail-Order Electronics 24 HOUR ORDER HOTLINE ALL OTHER INQUIRIES (7AM-5PM PST) 415-592-8097 415-592-8121

NEC V20 & V30 CHIPS

Table with 3 columns: Part No., Description, Price. Includes items like UPD70108-5, UPD70108-8, etc.

7400

Table with 4 columns: Part No., 1-9, 10+, 1-9, 10+. Lists various 7400 series chips.

74LS

Table with 4 columns: Part No., Description, Price. Lists 74LS series chips.

74S/PROMS*

Table with 3 columns: Part No., Description, Price. Lists 74S and PROMS chips.

74F

Table with 3 columns: Part No., Description, Price. Lists 74F series chips.

CD-CMOS

Table with 3 columns: Part No., Description, Price. Lists CD-CMOS chips.

MICROPROCESSOR COMPONENTS

Table with 3 columns: Part No., Description, Price. Lists microprocessor components like MISCELLANEOUS CHIPS, 6500/6800/68000 Cont., 8000 SERIES Cont., etc.

MISC. COMPONENTS

Table with 3 columns: Part No., Description, Price. Lists miscellaneous components like TANTALUM CAPACITORS, POTENTIOMETERS, TRANSISTORS AND DIODES, etc.

MICROPROCESSOR SALE!

Table with 2 columns: Part No., Description, Price. Lists microprocessors for sale like 8052AHBASIC CPU w/BASIC Interpreter, etc.

COMMODORE CHIPS

Table with 3 columns: Part No., Description, Price. Lists Commodore chips like OYNAMIC RAMS, STATIC RAMS, EPROMS, etc.

74HC HI-SPEED CMOS

Table with 3 columns: Part No., Description, Price. Lists 74HC HI-SPEED CMOS chips.

74HCT - CMOS TTL

Table with 3 columns: Part No., Description, Price. Lists 74HCT - CMOS TTL chips.

LINEAR

Table with 3 columns: Part No., Description, Price. Lists linear components like DS0026CN, LM1458N, etc.

PARTIAL LISTING • OVER 4000 COMPONENTS AND ACCESSORIES IN STOCK! • CALL FOR QUANTITY DISCOUNTS

*RAM'S SUBJECT TO FREQUENT PRICE CHANGES

CIRCLE 114 ON FREE INFORMATION CARD

www.americanradiohistory.com

SEND FOR
FREE
1988 CATALOG...
56 PAGES

★ QUALITY PARTS ★ DISCOUNT PRICES ★ FAST SHIPPING

ALL ELECTRONICS CORP.

WE STOCK OVER
4,000 ITEMS...
CALL OR WRITE FOR OUR
FREE
CATALOG OF PARTS!

RESISTORS • CAPACITORS • DIODES • CABLES • BRIDGE RECTIFIERS • CHOKE COILS • CRYSTALS • CRIMP CONNECTORS • LAMPS • HEAT SINKS • MOTORS • SUB MINIATURE D CONNECTORS • TRANSISTORS • I.C.'S • PROTO BOARDS • POTENTIOMETERS • POWER SUPPLIES • JACKS • PLUGS • SWITCHES • PERF BOARDS • FANS • FUSES • SHRINK TUBING • TIE WRAPS • TOOLS • KEYPADS • VIDEO ACCESSORIES • RELAYS • S.C.R.'S • TRANSFORMERS • TELEPHONE ACCESSORIES • RIBBON CABLE • CIRCUIT BREAKERS • VOLTAGE REGULATORS • AND MANY OTHER ITEMS...

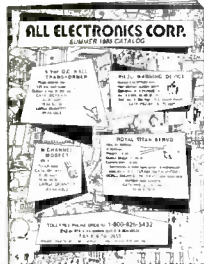

TRANSISTORS

CAT#	TYPE	CASE	PRICE
PN2222	NPN	TO-92	5 for .75
2N2904	PNP	TO-5	3 for \$1.00
2N2906	PNP	TO-18	3 for \$1.00
2N2907	PNP	TO-92	5 for .75
2N3055	NPN	TO-3	\$1.00 each
PN3569	NPN	TO-92	5 for .50
2N3904	NPN	TO-92	5 for .75
2N3906	PNP	TO-92	5 for .75
2N4400	NPN	TO-92	5 for .75
2N4402	PNP	TO-92	5 for .75
2N5400	PNP	TO-92	4 for \$1.00
2N5880	PNP	TO-3	\$2.00 each
2N5882	NPN	TO-3	\$2.00 each
MJE2955	PNP	TO-3	1.50 each
MJE2955T	PNP	TO-220	.75 each
MJE3055T	NPN	TO-220	.75 each
TIP30	NPN	TO-220	.75 each
TIP31	NPN	TO-220	.75 each
TIP32	PNP	TO-220	.75 each
TIP41	NPN	TO-220	.75 each
TIP42	PNP	TO-220	.75 each
TIP121	NPN	TO-220	.75 each
TIP126	PNP	TO-220	.75 each

10 AMP SOLID STATE RELAYS

ELECTROL# S2181 CONTROL:
Rated 5.5 to 10 Vdc
Will operate on 3-32 Vdc
LOAD:
10 Amp @ 240 Vac
2 1/4" X 1 3/4" X 7/8"
CAT# SSRLY-10B \$9.50 each
QUANTITY DISCOUNT!
10 for \$85.00
25 for \$175.00
50 for \$300.00
100 for \$500.00

SWITCHES

MINIATURE TOGGLE SWITCHES all rated 5 Amps

S.P.D.T. (on-on)
Solder lug terminals.
CAT# MTS-4 \$1.00 each 10 for \$9.00

S.P.D.T. (on-on)
Non threaded bushing. P.C. mount.
CAT# MTS-40PC 75¢ each 10 for \$7.00

D.P.D.T. (on-on)
Solder lug terminals.
CAT# MTS-8 \$2.00 each 10 for \$19.00

PIEZO WARNING DEVICE

Murata Erie # PKB8-4A0
High pitched audible alarm.
Operates on 3-20 Vdc @ 20 ma. 1" high X 7/8" dia. P.C. board mount.
CAT# PBZ-84 \$1.75 each

SOUND ACTIVATED BOARD

Designed to react to high pitched sounds. Each board contains many useful parts including a condenser mike.
Operates on 6 Vdc.
Instructions included.
CAT# SAB \$2.50 each

24 VOLT D.C. SOLENOID

Intermittent duty cycle. 240 ohm coil.
Mounting flange is 1 1/8" wide.
Solenoid body 1 1/2" X 1/2" X 1/2".
CAT# SOL-34 \$1.00 each - 10 for \$8.50
100 for \$75.00 Large Quantity Available

MINI PUSH BUTTON

S.P.S.T. momentary.
Push to make. 1/4" threaded bushing.
Red button.
CAT# MPB-1 35¢ each - 10 for \$3.25

SOUND & VIDEO MODULATOR

TM UM1381-1.
Designed for use with T.I. computers. Can be used with video cameras, games, or other audio/video sources.
Built in A/B switch enables user to switch from T.V. antenna without disconnection. Operates on channel 3 or 4. Requires 12 Vdc.
Hook up diagram included.
CAT# AVMOD \$5.00 each

GRAB BAGS \$1.00 EACH

50 ASSORTED DISC CAPS.
Cut leads. Many common values. Some are 500 volts.
CAT# GRABDC

ASSORTED 1/4 WATT RESISTORS
Approximately 200 pieces of assorted values, some cut leads.
CAT# GRES

ITT PUSH BUTTON

ITT MDPL series. 3/4" X 1/2" gray rectangular key cap.
S.P.S.T. N.O. Push to close.
RATED:
0.1amp switching.
0.25 amp carry current. P.C. mount
CAT# PB-8 65¢ each 10 for \$6.00 - 100 for \$50.00

XENON TUBE

1" long flashtube prepped with 3 1/2" red and black leads. Ideal for electronic flash or strobe projects.
CAT# FLT-3 2 for \$1.00

NEW! STROBE KIT

Variable rate strobe kit, flashes between 60 to 120 times per minute. Will operate on either 6 or 12 Vdc depending upon how you wire the circuit. Comes complete with P.C. board and instructions for easy assembly.
CAT# STROBE-1 \$7.50 each

NICKEL-CAD (RECHARGEABLE) BATTERIES

SPECIAL
AAA SIZE
Panasonic # P-18AAA
1.2 volt @ 180 mAh
CAT# NCB-AAAX \$1.50 each 10 for \$13.50 100 for \$125.00
LARGE QUANTITIES

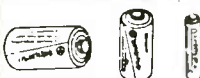

AA SIZE \$2.00 each
1.25 Volts 500 mAh
CAT# NCB-AA

AA SIZE \$2.20 each
WITH SOLDER TABS
CAT# NCB-SAA

C SIZE \$4.25 each
1.2 Volts 1200 mAh
CAT# NCB-C

D SIZE \$4.50 each
1.2 Volts 1200 mAh
CAT# NCB-D

WALL TRANSFORMERS

ALL PLUG DIRECTLY INTO
120 VAC OUTLET

6 Vdc @ 200 ma. \$2.25
CAT# DCTX-620

6 Vdc @ 750 ma. \$3.50
CAT# DCTX-675

9 Vdc @ 250 ma. \$2.50
CAT# DCTX-925

12 Vac @ 930 ma. \$3.50
CAT# ACTX-1293

18 Vac @ 1 Amp. \$3.50
CAT# ACTX-1885

PROTO BOARD

Large enough to design most experimental circuits. This proto board measures 6 3/4" X 2 1/2". Contains main board and two power buss strips.
CAT# PB-101 \$9.00 each

FULL WAVE BRIDGE RECTIFIERS

10 AMP 200 P.I.V.
5/8" SQUARE
CAT# FWB-1020 \$1.00 each - 10 for \$9.00

25 AMP RATING
1 1/8" SQUARE metal epoxy filled case

200 P.I.V. \$2.50 each
CAT# FWB-252

400 P.I.V. \$3.00 each
CAT# FWB-254

600 P.I.V. \$3.50 each
CAT# FWB-256

WATER TIGHT ENCLOSURE

ROSE# 02081905
Molded fiberglass enclosure with neoprene gasket.
2" X 3" X 7 1/2". Light blue.
CAT# WP-905 \$7.50 each

N-CHANNEL MOSFET

IRF-511 TO-220 case
CAT# IRF 511 \$1.00 each 10 for \$9.00
LARGE QUANTITY AVAILABLE...

HALL EFFECT SWITCH

MICROSWITCH #4BE3
Slanted keyboard switch with hall effect sensor.
Snaps into 5/8" square chassis hole. Hall effect sensor slides easily from switch and can be used in other applications.
CAT# HESW 4 for \$1.00 10 for \$2.00 100 for \$15.00

FLASHING L.E.D. KIT

Two L.E.D.'s flash in unison when a 9 volt battery is attached. Requires easy assembly, you solder the parts to the circuit board.
CAT# LEDKIT \$1.50 each

LIGHT EMITTING DIODES (L.E.D.)

STANDARD JUMBO LED DIFFUSED
T 1-3/4 size

RED 10 for \$1.50
CAT# LED-1 100 for \$13.00 1000 for \$110.00

GREEN 10 for \$2.00
CAT# LED-2 100 for \$17.00 1000 for \$150.00

YELLOW 10 for \$2.00
CAT# LED-3 100 for \$17.00 1000 for \$150.00

FLASHING LED with built in flashing circuit. operates on 5 volts.

RED \$1.00 each
CAT# LED-4 10 for \$9.50

GREEN \$1.00 each
CAT# LED-4G 10 for \$9.50

BI-POLAR LED
Lights RED one direction, GREEN the other. Two leads.
CAT# LED-6 2 for \$1.70

LED HOLDER Two piece holder.
CAT# HLED 10 for 65¢

CLIPLITE LED HOLDER Makes a L.E.D. look like a fancy indicator. Fits T 1-3/4 size LED.

CLEAR CAT# HLDCL-C
RED CAT# HLDCL-R
GREEN CAT# HLDCL-G
YELLOW CAT# HLDCL-Y

MAIL ORDERS TO:
ALL ELECTRONICS
P.O. BOX 567
VAN NUYS, CA 91408

TWX-5101010163
(ALL ELECTRONIC)

OUTSIDE THE U.S.A.
SEND \$1.50 POSTAGE
FOR A CATALOG!!

STORES:

LOS ANGELES
905 S. VERMONT AVE.
LOS ANGELES, CA 90006
(213)380-8000

VAN NUYS
6228 SEPULVEDA BLVD.
VAN NUYS, CA 91411
(818)997-1806

TOLL FREE
800-826-5432

INFO: (818)904-0524
FAX: (818)781-2653
MINIMUM ORDER \$10.00
QUANTITIES LIMITED

CALIF. ADD SALES TAX
USA: \$3.00 SHIPPING
FOREIGN ORDERS
INCLUDE SUFFICIENT
SHIPPING.



NO C.O.D.

HERE'S WHAT IS NEW AT MCM ELECTRONICS

Tenma Pocket DMM

Pocket size autorange DMM. Simply select function and meter automatically selects proper range for most accurate reading.

FEATURES: 1 YEAR LIMITED WARRANTY

- 3½ digit LCD display
- Data hold: Holds display reading after meter is removed from circuit
- Audible continuity tester
- Diode test
- Comes in folding case complete with test leads and owners manual



#72-600

Tenma Probe Style DMM

Probe style DMM for convenient one hand operation.

FEATURES: 1 YEAR LIMITED WARRANTY

- 3½ digit LCD display
- Data hold: Holds display reading after meter is removed from circuit
- Audible continuity tester
- Diode test



#72-610

Tenma Isolation Transformer

Provides isolation from AC line when servicing "hot" chassis equipment. Eliminates shock hazard and prevents damage to AC line operated test equipment.



#72-545

FEATURES:

- Fused 150VA isolated outlet
- Fused 550VA direct outlet
- Illuminated power switch
- UL approved

Quick Shot Joystick

- Compatible with Nintendo Entertainment System
- Six positive response micro-switches
- Contoured pistol grip
- Select/start switch
- Auto-fire switch
- Four stabilizing suction cups

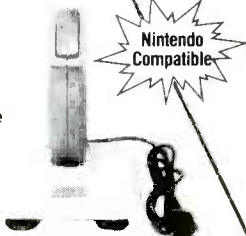

#83-0280

RS-232 Type Port Switch

- Eliminates the need to plug and unplug cables when you need to use a different peripheral device
- Enables user to access one printer from different computers, or access multiple printers from one computer with the turn of a switch
- Female connectors
- All pins switched pin for pin

Two-Way
#83-605



Tenma Anti-Static Keyboard Mat

- Provides static protection while working at a computer terminal
- Light gray
- Dimensions: 8" (W) x 18" (L)

#21-885



Blue Shower #20-845

- Cleans particulate, ionic and non-ionic debris and contaminants from all electronic components and circuitry
- Penetrates minute cracks and crevices, lifting out grease and dirt
- Safe on plastics and materials used in electronic circuitry (may not be safe on plastic cabinet trim)
- Use on tuners, potentiometers, solenoids, tube sockets and more
- Recommend using Blue Stuff after cleaning with Blue Shower
- 24 oz.



Blue Stuff #20-850

- Formulated with MINISCRUBBERS™ tuner contact polishers; that continue to polish even after months of use
- MINISCRUBBERS™ are dispersed throughout a special super-smooth tuner lubricant that won't create tuner drag or contact wear
- Safe on all plastics
- 8 oz.

#20-850

Automatic CD Cleaner #80-320

- Motorized chamois cleaning system provides true radial cleaning
- Cleaner automatically stops when finished
- Can be used wet or dry
- 1 oz. bottle of cleaning fluid included
- Operates on four "AA" batteries (not included)

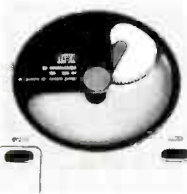

#80-320

See Catalog 18 pages 8-23 for full specifications and more test equipment.

For your **FREE** copy, call **TOLL-FREE**
1-800-543-4330

In Ohio, call 1-800-762-4315

In Alaska or Hawaii, call 1-800-858-1849

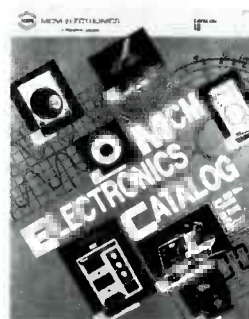

MCM ELECTRONICS
858 E. CONGRESS PARK DR.
CENTERVILLE, OH 45459-4072
A PREMIER Company

CIRCLE 87 ON FREE INFORMATION CARD

www.americanradiohistory.com

SOURCE NO. RE-50

NEW ACCESSORIES FOR THE MOTION CONTROL SYSTEM

SCANNER CONNECTS TO THE VIDEO LOGIC BOARD AND ALLOWS THE SYSTEM TO MONITOR 92 SWITCH/RELAY CONTACTS ASSEMBLED & TESTED ORDER NUMBER 50/04 ADD \$4 FOR SHIPPING & HANDLING **35.00**

SPIN CONNECTS TO THE SERIAL PORTS AND ALLOWS PULSE WIDTH MODULATION OF TWO DC SERVO MOTORS TRANSPARENT TO NORMAL USE OF SERIAL PORTS OPTICAL ENCODER FEED BACK KEEPS THE MOTORS UNDER CONTROL! INCLUDES REFLECTIVE LEDS, ENCODER DISKS, DRIVER KIT, AND SOFTWARE. H PATTERN DRIVERS ALLOW FORWARD & REVERSE FROM ONE 12 VOLT POWER SUPPLY. FOR USE WITH MOTORS UP TO 6 AMPS AT 12 VDC ORDER NUMBER 50/05 ADD \$4 FOR SHIPPING & HANDLING **59.00**

POWER 8 AMPS OF POWER FOR LARGER MOTORS OUTPUT MAY BE SPLIT TO DRIVE 2 4 AMP MOTORS OR USE 2 TO DRIVE ONE 16 AMP MOTOR ORDER NUMBER 50/06 ADD \$3 FOR SHIPPING & HANDLING **19.99**

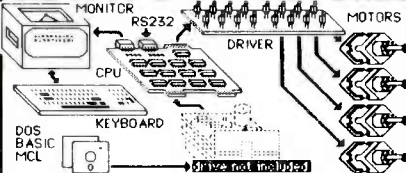

- GENERAL PURPOSE 64K SINGLE BOARD COMPUTER
- AMBER MONITOR WITH 80 BY 24 LINES DISPLAY
- QUALITY KEYBOARD WITH KEYPAD & FUNCTION KEYS
- 4 "EASY STEPPER" MOTORS AND DRIVER KIT
- PDS/DOS MICROSOFT BASIC AND PILOT LANGUAGE
- MOTOR CONTROL PROGRAM WITH SOURCE LISTING
- POWER SUPPLIES INCLUDED OR USE YOUR BATTERIES
- FULLY DOCUMENTED INCLUDING SCHEMATICS
- ALL BOARDS EXCEPT THE DRIVER ARE PREASSEMBLED
- DISK STORAGE (not included) EXPANDABLE TO 3.2 MEG
- ORDER NUMBER 50/03. PLEASE ADD \$14 FOR S&H.

MOTION CONTROL SYSTEM \$149.00

Call for a copy of 15 day trial agreement. Tax & freight extra. COD to cont USA ok add \$3 to S&H Price may change Store price may differ. While supplies last. No PDs, terms, or credit cards

Silicon Valley Surplus
 415-261-4506
 4401 OAKPORT OAKLAND CA. 94601

OPEN 10am-6pm
 CLOSED SUN & MON

CIRCLE 51 ON FREE INFORMATION CARD

ADVERTISING INDEX

RADIO-ELECTRONICS does not assume any responsibility for errors that may appear in the index below.

Free Information Number	Page		
81	A.L.S. Satellite	81	61 Master Publishing
204	ACE	80	61 Microprocessors Unltd.
193	ACS Supply	81	— NRI
108	AMC Sales	26	203 On Target
—	AMICOM	102	191 Optoelectronics
186	Active Electronics	107	— Pacific Cable
107	All Electronics	118	56 Parts Express
—	Amazing Devices	104	68 Philips ECG
106	American Design Components	114	198 Print Products International
84	Appliance Service	81	78 Radio Shack
76	Associated Electronics/3M	7	184, 185 Sencore
201	Atlantic Cable Distribution	76	51 Silicon Valley Surplus
77	B&K Precision	17	83 Synergetics
183	Banner Technical Books	28	92 Tektronix
85	Blue Star Industries	82	194 Tentel
—	Breath Alert	96	123 Test Probes
109	C & S Sales	44	196 U.S. Instrument Rentals
189	CEI	120	192 WPT Publications
60	CIE	18	
50	Caig Laboratories	16	
202	California Software	95	
190	Chenesko Products	82	
—	Command Productions	80	
177	Communications Specialists	99	
58	Cook's Institute	15	
187	Crystek	28	
—	Damark International	5	
127	Deco Industries	81, 82	
82	Digi-Key	106	
—	Digital Research Computers	102	
—	Electronics Book Club	38	
200	Elenco	5	
121	Fluke Manufacturing	CV2	
—	Fordham Radio	CV4	
—	GTC Industries	82	
197	Global Specialties	15	
—	Grantham College of Engineering	26	
86	Heath	37	
65	J & W	70	
59	JDR Instruments	27	
113, 178	JDR Microdevices	108, 109	
179, 180	JDR Microdevices	110, 111	
181	JDR Microdevices	112	
114	Jameco	116	
115	Jensen Tools	82	
—	Joseph Electronics	25	
199	Kelvin	76	
195	Kikusui	23	
—	Lindsay Publications	43	
182	M Test Equipment	82	
87	MCM Electronics	119	
53	MD Electronics	104	
93	Mark V. Electronics	105	

Gernsback Publications, Inc.
 500-B Bi-County Blvd.
 Farmingdale, NY 11735
 (516) 293-3000
 President: Larry Steckler
 Vice President: Cathy Steckler

For Advertising ONLY
 516-293-3000
Larry Steckler
 publisher
Arline Fishman
 advertising director
Shelli Weinman
 advertising associate
Lisa Strassman
 credit manager
Christina Estrada
 advertising assistant

SALES OFFICES

EAST/SOUTHEAST
Stanley Levitan
 Eastern Sales Manager
 Radio-Electronics
 259-23 57th Avenue
 Little Neck, NY 11362
 718-428-6037, 516-293-3000

MIDWEST/Texas/Arkansas/Okla.
Ralph Bergen
 Midwest Sales Manager
 Radio-Electronics
 540 Frontage Road—Suite 339
 Northfield, IL 60093
 312-446-1444

PACIFIC COAST/ Mountain States
Marvin Green
 Pacific Sales Manager
 Radio-Electronics
 5430 Van Nuys Blvd. Suite 316
 Van Nuys, CA 91401
 1-818-986-2001

CONSOLIDATED ELECTRONICS

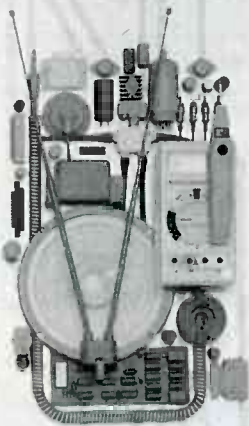

CONSUMER & INDUSTRIAL ELECTRONICS CATALOG • 17TH EDITION

THE ULTIMATE ELECTRONICS CATALOG.

Order your 260 page catalogue packed with over 10,000 money saving electronic parts and equipment. Send \$3.00 check or money order, or call 1-800-543-3568 today and use your MasterCard or Visa
 Consolidated Electronics, Incorporated
 705 Watervliet Ave., Dayton, Ohio 45420-2599

NAME _____
 ADDRESS _____
 CITY _____
 STATE _____ ZIP _____

CIRCLE 189 ON FREE INFORMATION CARD

With Just One Probe Hookup You Can Confidently Analyze Any Waveform To 100 MHz, 10 Times Faster, 10 Times More Accurately, Absolutely Error Free, Guaranteed Or Your Money Back . . .



**With The SC61 Waveform Analyzer
\$3,295.00 PATENTED**

Promises of increased productivity from other oscilloscopes fade fast when compared to the speed and accuracy of the SC61. Eliminate the confusing menus, cursors and complexity of regular oscilloscopes at the push of a button. Here's what the SC61 does for you:

Analyze Waveforms Easily

- Accurate Waveform Display - 60 MHz Bandwidth (useable To 100 MHz) To Test The Latest Digital Circuits.
- Rock-Solid Sync - ECL Logic Circuits And Differential Amplifiers Give Fiddle Free Operation.
- Four Times The Measuring Range - Measure From 5 mV To 2000 Volts (3000 Volts Protection) For Expanded Signal Handling.

Autotracking™ Digital Readings Analyze The Whole Signal

- Autoranging DC Volts Through Single Probe, Even With AC Coupled.
- Automatic Peak-To-Peak Volts - Even If Variable Control Is "Out Of Cal".
- Automatic Frequency Measurements Without Sensitivity Adjustment Or Range Switching.

CIRCLE 184 ON FREE INFORMATION CARD

Digital Delta Tests Analyze Any Part Of The Signal.

- Delta Peak-To-Peak Volts - Peak-To-Peak Volts Of Any Part Of The Signal.
- Delta Time For Any Time Reading - Including Delay Between Traces
- 1/Delta Time - Frequency Of Part Of The Signal - Finds Sources Of Interference Or Ringing.

Frequency Ratio Test - Tests Multiplier And Divider Circuits

Easy To Use - Human Engineered Controls And Virtually No Graticule Counting Or Calculations

The SC61 is designed to give you the measurements you need - fast. We make one claim:

"Try the SC61 on your bench for 30 days. If it doesn't cut your present scope time in half, send it back for a complete refund, no questions asked."

Try the SC61 for 30 days, and discover true troubleshooting speed.

**Call 1-800-843-3338
In Canada Call 1-800-851-8866**

SENCORE

Fordham measures up

Quality • Price • Delivery

Mini-Meters with Maxi-Specs



SCOPE 3 1/2 Digit LCD Meter

- 0.5% Accuracy • DC Voltage • AC Voltage • DC Current • Resistance • Diode Test • Battery Life 300 Hrs. • Overload Protection: DC 500V, AC 350V, ohms 25CV DC/AC.

Model DVM-630
Our Price **\$2995**

Zippered carrying case
CC-30 \$4.50

NEW! SCOPE 3 1/2 Digit, LCD 8 Function with Transistor Tester

- 0.5% Accuracy • Audible continuity and diode test • 10 Amp measurement • Resistance • DC/AC Voltage.

Model DVM-632
Reg. \$60.00
Our Price **\$4495**

Zippered carrying case
CC-30 \$4.50

SCOPE 3 1/2 Digit LCD with Autoranging

- 0.5% Accuracy • Auto/Manual range selection • DC Voltage • AC Voltage • AC Current • DC Current • Resistance.

Model DVM-631
Our Price **\$4995**

Special

Deluxe carrying case
CA-92 \$9.95

SCOPE Hand-Held Digital Multimeters

- Overload protection • Auto-decimal LCD readout • Polarity indication • 300 hr. 9V battery life • Low battery indicator.

- 8 Function, 37 ranges including Transistor and Capacitance measurements

Model DVM-636
Our Price **\$6750**



- 11 Function, 38 ranges including Logic Level Detector, Audible and Visual Continuity, Capacitance and Conductance measurements

Model DVM-638
Our Price **\$8750**



CA-92 Deluxe Padded Case for DVM meters. \$9.95
TL-216 Transistor and Capacitance Test Leads \$9.90



NEW!
SCOPE Frequency Counters
• 8-digit LED • Compact • lightweight
• High performance • Automatic range and Hold function • High stability in reference oscillator.

Model FC-7011
100 MHz Our Price **\$14995**

Model FC-7051
550 MHz Our Price **\$19995**



FORDHAM Frequency Counter
• 10 Hz - 150 MHz Range • 7-digit LED display • VHF/HF selection • Gate time 1 sec., 5 sec. • ±1 count accuracy.

Model FC-150
Our Price **\$13990**



NEW
FORDHAM Function Generator
• 0.5 Hz - 500 KHz in 6 ranges • Sine, square & triangle wave forms • VCA and VCF inputs • Accuracy ±5% of full scale.

Model FG-202
Our Price **\$14990**



FORDHAM Signal Tracer/Injector
• Easy to operate • VU meter • Two LED mode indicators • 1 KHz test tone • 8 ohm speaker • Test leads.

Model SE-610
Our Price **\$11990**



FORDHAM LCR Bridge Meter
• Fully transistorized • 1 KHz signal generator • Measures resistance • Inductance • High mechanical and electrical stability • Battery operated.

Model LC-340
Our Price **\$14995**



SCOPE Digital Capacitance Meter
• Digital LCD display • LSI-circuit • High accuracy: 100 ppm 0.5% • Broad test range • Fast sampling time • Capacitor discharge protection • Compact, lightweight design • One-hand operation.

Model DCM-602
Our Price **\$5995**

Telephone Orders Now! EVERYDAY INCLUDING SATURDAY
Mon. - Fri. 8 a.m. - 6:30 p.m. EST. Sat. & Sun. 9 a.m. - 3 p.m. EST

ASK FOR FREE CATALOG. Money orders, checks accepted. C.O.D.'s require 25% deposit



Fordham

260 Motor Parkway, Hauppauge, NY 11788

Toll Free **800-645-9518**

In NY State 800-832-1446

Service & Shipping Charge Schedule	
Continental U.S.A.	
FOR ORDERS	ADD
\$25-50	\$4.50
\$51-100	\$5.50
\$101-200	\$7.00
\$201-300	\$8.00
\$301-400	\$9.00
\$401-500	\$10.00
\$501-750	\$12.50
\$751-1000	\$15.00
\$1001-1,250	\$17.50
\$1,251-1,500	\$20.00
\$1,501-2000	\$25.00
\$2,001 and Up	\$30.00